

PROCESS SPECIFICATION
HPS40-2 2+2
Female Connector SCC

EVS-100111



HIRSCHMANN
AUTOMOTIVE



Table of contents

1	General.....	10
1.1	Document.....	10
1.2	Processing	11
1.3	Equipment.....	13
1.4	Process parameters	14
1.5	Purpose	15
1.6	Additionally documents	16
1.7	Characteristics and customer approvals.....	17
1.7.1	Customer: Miscellaneous	17
1.7.2	Customer: BMW	18
2	Product structure	19
2.1	Bill of materials.....	19
2.1.1	HPS40-2 2+2 female connector SCC 4.0 mm ² with HVIL	19
2.1.2	HPS40-2 2+2 female connector SCC 4.0 mm ² without HVIL.....	21
2.1.3	HPS40-2 2+2 female connector SCC 6.0 mm ² with HVIL	23
2.1.4	HPS40-2 2+2 female connector SCC 6.0 mm ² without HVIL.....	25
2.2	Approved cables	27
2.2.1	Single core cables 4.0 mm ²	27
2.2.2	Single core cables 6.0 mm ²	28
2.3	Article representation	29
2.3.1	HPS40-2 2+2 locking sleeve.....	29
2.3.2	HPS40-2 2+2 female contact carrier 4.0 mm ²	30
2.3.3	HPS40-2 2+2 female contact carrier 4.0 mm ² & 6.0 mm ² SCC	31
2.3.4	HPS40-2 2+2 shielding sleeve 4.0 mm ² & 6.0 mm ² SCC	32
2.3.5	HPS40-2 2+2 ferrule crimp 4.0 mm ² SCC.....	33
2.3.6	HPS40-2 2+2 stress relief 6.0 mm ² SCC	34
2.3.7	HPS40-2 2+2 X-Ring 6.0 mm ² SCC.....	35
2.3.8	HPS40-2 2+2 cable seal 4.0 mm ² & 6.0 mm ² SCC	36
2.3.9	HPS40-2 2+2 cover cap 4.0 mm ² & 6.0 mm ² SCC non-polarized.....	37
2.3.10	HPS40-2 2+2 cover cap 4.0 mm ² & 6.0 mm ² SCC polarized.....	38
2.3.11	HCT4 female terminal.....	39
2.3.12	HPS40-2 2+2 coding clip (optional part).....	40
2.3.13	HPS40-2 2+2 90° angled cap (optional part).....	41
2.3.14	HPS40-2 2+2 protection cap (optional part)	42
2.3.15	HPS40-2 2+2 In-Line CPA cover (optional part for HPS In-Line).....	43
3	Processing steps 4.0 mm ² SCC	44
3.1	Cutting the cable	44
3.2	Assemble individual components	45
3.3	Strip off the cable	46
3.4	Remove shielding foil (if present), trim shielding braid, and crimp the ferrule crimp	47
3.5	Fold over the shielding braid and secure the shielding braid.....	50
3.6	Crimp the HCT4 female terminal	53
3.7	Inserting HCT4 female terminals into the contact carrier.....	55
3.8	Close secondary lock on the contact carrier	58



3.9	Slide the shielding sleeve onto the contact carrier	59
3.10	Crimp the shielding sleeve	61
3.10.1	Cable shielding crimping using two half-shells	63
3.10.2	Crimp the contact carrier	69
3.11	Optional fixation of the cables	72
4	Processing steps 6.0 mm ² SCC	73
4.1	Cutting the cable	73
4.2	Assemble individual components	74
4.3	Strip off the cable	75
4.4	Remove shielding foil (if present), trim shielding braid, and assembly the stress relief and X-Ring	76
4.5	Crimp the HCT4 female terminal	79
4.6	Inserting HCT4 female terminals into the contact carrier	80
4.7	Close secondary lock on the contact carrier	83
4.8	Slide the shielding sleeve onto the contact carrier	84
4.9	Crimp the shielding sleeve	86
4.9.1	Cable shielding crimping using two half-shells	88
4.9.2	Crimp the contact carrier	93
5	Completion steps 4.0 mm ² & 6.0 mm ² SCC	96
5.1	Assemble the locking sleeve	96
5.2	Assemble the cable seal and cover cap	99
6	Completion steps 4.0 mm ² & 6.0 mm ² SCC (optional parts)	101
6.1	Assemble the In-Line CPA cover	101
6.2	Assemble the 90° angled cap	103
6.3	Assemble the coding clip on the cover cap	106
6.4	Assemble the coding clip on the 90° angled cap	108
6.5	Assemble the protection cap	109
7	Technical information	110
7.1	Storage of the finished wiring harness	110
7.2	Technical cleanliness	110
7.2.1	Customer: Miscellaneous	110
7.2.2	Customer: BMW	111
7.3	Automation possibilities	112
7.4	Sample preparation for shielding retention force	112
7.4.1	Manipulation of primary and secondary locking	112
7.4.2	Removal of HCT4 female terminals after shielding crimping	113
8	Appendix	114
9	Change of documentation	117



List of tables

Table 1.1: Overview product variants (1.5 Purpose)	15
Table 1.2: Overview additionally relevant documents (1.6 Additionally relevant documents).....	16
Table 1.3: Overview characteristics for customer miscellaneous (1.7 Characteristics and customer approvals).....	17
Table 1.4: Overview characteristics for customer BMW (1.7 Characteristics and customer approvals)	18
Table 2.1: Overview BOM HPS40-2 2+2 female connector SCC 4.0 mm ² with HVIL, Customer: Miscellaneous (2.1 Bill of materials)	19
Table 2.2: Overview BOM HPS40-2 2+2 female connector SCC 4.0 mm ² with HVIL, Customer: BMW (2.1 Bill of materials).....	20
Table 2.3: Overview BOM HPS40-2 2+2 female connector SCC 4.0 mm ² with HVIL, Customer: Stellantis (2.1 Bill of materials)	20
Table 2.4: Overview BOM HPS40-2 2+2 female connector SCC 4.0 mm ² without HVIL, Customer: Miscellaneous (2.1 Bill of materials)	21
Table 2.5: Overview BOM HPS40-2 2+2 female connector SCC 4.0 mm ² without HVIL, Customer: BMW (2.1 Bill of materials)	22
Table 2.6: Overview BOM HPS40-2 2+2 female connector SCC 6.0 mm ² with HVIL, Customer: Miscellaneous (2.1 Bill of materials)	23
Table 2.7: Overview BOM HPS40-2 2+2 female connector SCC 6.0 mm ² with HVIL, Customer: BMW (2.1 Bill of materials).....	24
Table 2.8: Overview BOM HPS40-2 2+2 female connector SCC 6.0 mm ² with HVIL, Customer: Stellantis (2.1 Bill of materials)	24
Table 2.9: Overview BOM HPS40-2 2+2 female connector SCC 6.0 mm ² without HVIL, Customer: Miscellaneous (2.1 Bill of materials)	25
Table 2.10: Overview BOM HPS40-2 2+2 female connector SCC 6.0 mm ² without HVIL, Customer: BMW (2.1 Bill of materials)	26
Table 2.11: Overview approved SCC 4.0 mm ² (2.2 Approved cables).....	27
Table 2.12: Overview approved SCC 6.0 mm ² (2.2 Approved cables).....	28
Table 2.13: Overview HPS40-2 2+2 locking sleeve (2.3 Article representation)	29
Table 2.14: Overview HPS40-2 2+2 female contact carrier 4.0 mm ² (2.3 Article representation).....	30
Table 2.15: Overview HPS40-2 2+2 female contact carrier 4.0 mm ² & 6.0 mm ² SCC (2.3 Article representation)	31
Table 2.16: Overview HPS40-2 2+2 shielding sleeve 4.0 mm ² & 6.0 mm ² SCC (2.3 Article representation)	32
Table 2.17: Overview HPS40-2 2+2 ferrule crimp 4.0 mm ² SCC (2.3 Article representation).....	33
Table 2.18: Overview HPS40-2 2+2 stress relief 6.0 mm ² SCC (2.3 Article representation)	34
Table 2.19: Overview HPS40-2 2+2 X-Ring 6.0 mm ² SCC (2.3 Article representation)	35
Table 2.20: Overview HPS40-2 2+2 cable seal 4.0 mm ² & 6.0 mm ² SCC (2.3 Article representation)	36
Table 2.21: Overview HPS40-2 2+2 cover cap 4.0 mm ² & 6.0 mm ² SCC non-polarized (2.3 Article representation)	37
Table 2.22: Overview HPS40-2 2+2 cover cap 4.0 mm ² & 6.0 mm ² SCC polarized (2.3 Article representation)	38
Table 2.23: Overview HCT4 female terminal (2.3 Article representation)	39
Table 2.24: Overview HPS40-2 2+2 coding clip, optional part (2.3 Article representation)	40
Table 2.25: Overview HPS40-2 2+2 90° angled cap, optional part (2.3 Article representation)	41
Table 2.26: Overview HPS40-2 2+2 protection cap, optional part (2.3 Article representation)	42
Table 2.27: Overview HPS40-2 2+2 In-Line CPA cover, optional part for HPS In-Line (2.3 Article representation).....	43
Table 3.1: Overview 4.0mm ² SCC dimension D0 (3.1 Cutting the cable)	44
Table 3.2: Overview 4.0mm ² SCC dimension D1 (3.3 Strip off the cable).....	46
Table 3.3: Overview 4.0 mm ² SCC dimension D2 (3.4 Remove shielding foil (if present), trim shielding braid, and crimp the ferrule crimp).....	47
Table 3.4: Overview 4.0 mm ² SCC dimension DØ0 (3.4 Remove shielding foil (if present), trim shielding braid, and crimp the ferrule crimp)	48
Table 3.5: Overview 4.0 mm ² SCC dimension D4 (3.5 Fold over the shielding braid and secure the shielding braid)	52
Table 3.6: Overview 4.0 mm ² SCC dimension D5, D6 and D7 (3.6 Crimp the HCT4 female terminal)	53
Table 3.7: Overview 4.0 mm ² SCC maximum permissible assembly force (3.7 Inserting HCT4 female terminals into contact carrier).....	56
Table 3.8: Overview 4.0 mm ² SCC dimension D8 and D9 (3.10 Crimp the shielding sleeve)	62
Table 3.9: Overview 4.0 mm ² SCC dimension D10 (3.10.1 Cable shielding crimping using two half-shells)	63
Table 3.10: Overview 4.0 mm ² SCC dimension D11, plunger and anvil version A for 809-887-001 (3.10.1 Cable shielding crimping using two half-shells).....	66
Table 3.11: Overview 4.0 mm ² SCC dimension D11, plunger and anvil version B for 807-655-... (3.10.1 Cable shielding crimping using two half-shells).....	66
Table 3.12: Overview 4.0 mm ² SCC dimension D12 (3.10.1 Cable shielding crimping using two half-shells)	67



Table 3.13: Overview 4.0 mm ² SCC pull-off force shielding sleeve (3.10.1 Cable shielding crimping using two half-shells)	68
Table 3.14: Overview 4.0 mm ² SCC dimension D13 (3.10.2 Crimp the contact carrier).....	69
Table 3.15: Overview 4.0 mm ² SCC dimension D14 (3.10.2 Crimp the contact carrier).....	71
Table 4.1: Overview 6.0mm ² SCC dimension D15 (4.1 Cutting the cable).....	73
Table 4.2: Overview 6.0mm ² SCC dimension D16 (4.3 Strip off the cable).....	75
Table 4.3: Overview 6.0 mm ² SCC dimension D17 (4.4 Remove shielding foil (if present), trim shielding braid, and assembly the stress relief and X-Ring).....	76
Table 4.4: Overview 6.0 mm ² SCC dimension D18 (4.4 Remove shielding foil (if present), trim shielding braid, and assemble the stress relief and X-Ring).....	78
Table 4.5: Overview 6.0 mm ² SCC dimension D19, D20 and D21 (4.5 Crimp the HCT4 female terminal).....	79
Table 4.6: Overview 6.0 mm ² SCC maximum permissible assembly force (4.6 Inserting HCT4 female terminals into contact carrier).....	81
Table 4.7: Overview 6.0 mm ² SCC dimension D22 (4.9 Crimp the shielding sleeve).....	87
Table 4.8: Overview 6.0 mm ² SCC dimension D23 (4.9.1 Cable shielding crimping using two half-shells)	88
Table 4.9: Overview 6.0 mm ² SCC dimension D24, plunger and anvil Version B (4.9.1 Cable shielding crimping using two half-shells)	90
Table 4.10: Overview 6.0 mm ² SCC dimension D25 (4.9.1 Cable shielding crimping using two half-shells)	91
Table 4.11: Overview 6.0 mm ² SCC pull-off force shielding sleeve (4.9.1 Cable shielding crimping using two half-shells)	92
Table 4.12: Overview 6.0 mm ² SCC dimension D26 (4.9.2 Crimp the contact carrier).....	93
Table 4.13: Overview 6.0 mm ² SCC dimension D27 (4.9.2 Crimp the contact carrier).....	95
Table 5.1: Overview 4.0 mm ² & 6.0 mm ² SCC dimension D28 & D29 (5.1 Assembling the locking sleeve)	97
Table 5.2: Overview 4.0 mm ² & 6.0 mm ² SCC dimension DØ1 (5.1 Assembling the locking sleeve)	98
Table 5.3: Overview 4.0 mm ² & 6.0 mm ² SCC dimension D30 (5.2 Assemble the cable seal and cover cap).....	100
Table 6.1: Overview 4.0 mm ² & 6.0 mm ² SCC dimension D31 (6.1 Assemble the In-Line CPA cover).....	102
Table 7.1: Overview 4.0 mm ² & 6.0 mm ² SCC technical cleanliness requirements for Customer: Miscellaneous (7.2 Technical cleanliness).....	110
Table 7.2: Overview 4.0 mm ² & 6.0 mm ² SCC technical cleanliness requirements for Customer: BMW (7.2 Technical cleanliness)	111
Table 8.1: Overview single stroke crimping machine for 3.4 Remove shielding foil (if present), trim shielding braid, and crimp the ferrule crimp (8 Appendix)	114
Table 8.2: Overview double stroke crimping machine for 3.6 Crimp the HCT4 female terminal & 4.5 Crimp the HCT4 female terminal (8 Appendix).....	114
Table 8.3: Overview pressing device for 3.10 Crimp the shielding sleeve & 4.9 Crimp the shielding sleeve (8 Appendix)	115
Table 8.4: Overview hand lever press for 5.1 Assemble the locking sleeve (8 Appendix).....	115
Table 8.5: Overview hand lever press for 6.1 Assemble the In-Line CPA cover (8 Appendix)	115
Table 8.6: Overview various stages of automation for 7.3 Automation possibilities (8 Appendix)	116



List of figures

Figure 2.1: Representation HPS40-2 2+2 locking sleeve (2.3 Article representation).....	29
Figure 2.2: Representation HPS40-2 2+2 female contact carrier 4.0 mm ² (2.3 Article representation)	30
Figure 2.3: Representation HPS40-2 2+2 female contact carrier 4.0 mm ² & 6.0 mm ² SCC (2.3 Article representation).....	31
Figure 2.4: Representation HPS40-2 2+2 shielding sleeve 4.0 mm ² & 6.0 mm ² SCC (2.3 Article representation).....	32
Figure 2.5: Representation HPS40-2 2+2 ferrule crimp 4.0 mm ² SCC (2.3 Article representation)	33
Figure 2.6: Representation HPS40-2 2+2 stress relief 6.0 mm ² SCC (2.3 Article representation).....	34
Figure 2.7: Representation HPS40-2 2+2 X-Ring 6.0 mm ² SCC (2.3 Article representation)	35
Figure 2.8: Representation HPS40-2 2+2 cable seal 4.0 mm ² & 6.0 mm ² SCC (2.3 Article representation).....	36
Figure 2.9: Representation HPS40-2 2+2 cover cap 4.0 mm ² & 6.0 mm ² SCC non-polarized (2.3 Article representation)	37
Figure 2.10: Representation HPS40-2 2+2 cover cap 4.0 mm ² & 6.0 mm ² SCC polarized (2.3 Article representation)	38
Figure 2.11: Representation HCT4 female terminal (2.3 Article representation)	39
Figure 2.12: Representation HPS40-2 2+2 coding clip, optional part (2.3 Article representation)	40
Figure 2.13: Representation HPS40-2 2+2 90° angled cap, optional part (2.3 Article representation)	41
Figure 2.14: Representation HPS40-2 2+2 protection cap, optional part (2.3 Article representation).....	42
Figure 2.15: Representation HPS40-2 2+2 In-Line CPA cover, optional part for HPS In-Line (2.3 Article representation)	43
Figure 3.1: Representation 4.0 mm ² SCC cable example (3.1 Cutting the cable)	44
Figure 3.2: Representation 4.0 mm ² SCC dimension X0 and dimension D0 (3.1 Cutting the cable)	44
Figure 3.3: Representation 4.0 mm ² SCC assemble individual components (3.2 Assemble individual components)	45
Figure 3.4: Representation 4.0 mm ² SCC pin assignment HPS40-2 2+2 cover cap 4.0 mm ² SCC polarized (3.2 Assemble individual components)	45
Figure 3.5: Representation 4.0 mm ² SCC stripped off cable example (3.3 Strip off the cable).....	46
Figure 3.6: Representation 4.0 mm ² SCC dimension D1 (3.3 Strip off the cable)	46
Figure 3.7: Representation 4.0 mm ² SCC remove shielding foil (if present), trim shielding braid, and crimp the ferrule crimp (3.4 Remove shielding foil (if present), trim shielding braid, and crimp the ferrule crimp).....	47
Figure 3.8: Representation 4.0 mm ² SCC dimension D2 (3.4 Remove shielding foil (if present), trim shielding braid, and crimp the ferrule crimp)	47
Figure 3.9: Representation 4.0 mm ² SCC maximum overlap of 2.0 mm (3.4 Remove shielding foil (if present), trim shielding braid, and crimp the ferrule crimp)	48
Figure 3.10: Representation 4.0 mm ² SCC dimension Ø X (3.4 Remove shielding foil (if present), trim shielding braid, and crimp the ferrule crimp)	48
Figure 3.11: Representation 4.0 mm ² SCC overhang shielding foil (3.4 Remove shielding foil (if present), trim shielding braid, and crimp the ferrule crimp)	48
Figure 3.12: Representation 4.0 mm ² SCC dimension D3 (3.4 Remove shielding foil (if present), trim shielding braid, and crimp the ferrule crimp)	49
Figure 3.13: Representation 4.0 mm ² SCC fold over the shielding braid and secure the shielding braid (3.5 Fold over the shielding braid and secure the shielding braid).....	50
Figure 3.14: Representation 4.0 mm ² SCC preserved shielding braid (3.5 Fold over the shielding braid and secure the shielding braid)	50
Figure 3.15: Representation 4.0 mm ² SCC fixing the shielding braid (3.5 Fold over the shielding braid and secure the shielding braid)	50
Figure 3.16: Representation 4.0 mm ² SCC 5.0 mm fixing tape (3.5 Fold over the shielding braid and secure the shielding braid)	51
Figure 3.17: Representation 4.0 mm ² SCC position fixing tape related to the ferrule crimp (3.5 Fold over the shielding braid and secure the shielding braid)	51
Figure 3.18: Representation 4.0 mm ² SCC position protruded shielding braid (3.5 Fold over the shielding braid and secure the shielding braid).....	51
Figure 3.19: Representation 4.0 mm ² SCC dimension D4 (3.5 Fold over the shielding braid and secure the shielding braid).....	52
Figure 3.20: Representation 4.0 mm ² SCC coroplast 837X/838X 5.0 mm tape (3.5 Fold over the shielding braid and secure the shielding braid)	52
Figure 3.21: Representation 4.0 mm ² SCC crimped HCT4 female terminal (3.6 Crimp the HCT4 female terminal)	53
Figure 3.22: Representation 4.0 mm ² SCC dimension D5 \diamond , D6 and D7 (3.6 Crimp the HCT4 female terminal).....	53



Figure 3.23: Representation 4.0 mm ² SCC dimension D5 reference edge (3.6 Crimp the HCT4 female terminal).....	54
Figure 3.24: Representation 4.0 mm ² SCC inserting into the contact carrier (3.7 Inserting HCT4 female terminals into contact carrier).....	55
Figure 3.25: Representation 4.0 mm ² SCC lead-in chamfers contact carrier (3.7 Inserting HCT4 female terminals into contact carrier).....	56
Figure 3.26: Representation 4.0 mm ² SCC plastic burr on contact carrier (3.7 Inserting HCT4 female terminals into contact carrier).....	57
Figure 3.27: Representation 4.0 mm ² SCC close secondary lock on the contact carrier (3.8 Close secondary lock on the contact carrier)	58
Figure 3.28: Representation 4.0 mm ² SCC pre-locking and locking position secondary lock (3.8 Close secondary lock on the contact carrier) ..	58
Figure 3.29: Representation 4.0 mm ² SCC slide the shielding sleeve onto the contact carrier (3.9 Slide the shielding sleeve onto the contact carrier).....	59
Figure 3.30: Representation 4.0 mm ² SCC risk of insulation failure (3.9 Slide the shielding sleeve onto the contact carrier).....	59
Figure 3.31: Representation 4.0 mm ² SCC polarization shielding sleeve and contact carrier (3.9 Slide the shielding sleeve onto the contact carrier).....	59
Figure 3.32: Representation 4.0 mm ² SCC end position shielding sleeve on contact carrier (3.9 Slide the shielding sleeve onto the contact carrier).....	60
Figure 3.33: Representation 4.0 mm ² SCC protruded fixing tape (3.9 Slide the shielding sleeve onto the contact carrier).....	60
Figure 3.34: Representation 4.0 mm ² SCC protruded individual shielding strands (3.9 Slide the shielding sleeve onto the contact carrier).....	60
Figure 3.35: Representation 4.0 mm ² SCC crimp the shielding sleeve (3.10 Crimp the shielding sleeve)	61
Figure 3.36: Representation 4.0 mm ² SCC shielding crimping and contact carrier crimping (3.10 Crimp the shielding sleeve)	61
Figure 3.37: Representation 4.0 mm ² SCC dimension D8 and D9 (3.10 Crimp the shielding sleeve)	62
Figure 3.38: Representation 4.0 mm ² SCC dimension D10 (3.10.1 Cable shielding crimping using two half-shells).....	63
Figure 3.39: Representation 4.0 mm ² SCC plunger and anvil Version A (3.10.1 Cable shielding crimping using two half-shells)	64
Figure 3.40: Representation 4.0 mm ² SCC plunger and anvil Version B (3.10.1 Cable shielding crimping using two half-shells)	65
Figure 3.41: Representation 4.0 mm ² SCC width of measuring instrument for dimension D11 (3.10.1 Cable shielding crimping using two half-shells).....	66
Figure 3.42: Representation 4.0 mm ² SCC shielding sleeve fold (3.10.1 Cable shielding crimping using two half-shells).....	67
Figure 3.43: Representation 4.0 mm ² SCC measurement area dimension D12 (3.10.1 Cable shielding crimping using two half-shells)	67
Figure 3.44: Representation 4.0 mm ² SCC dimension D11 and D12 (3.10.1 Cable shielding crimping using two half-shells).....	67
Figure 3.45: Representation 4.0 mm ² SCC pull-off force clamping position shielding sleeve (3.10.1 Cable shielding crimping using two half-shells).....	68
Figure 3.46: Representation 4.0 mm ² SCC dimension D13 and embossing positions a-d (3.10.2 Crimp the contact carrier).....	69
Figure 3.47: Representation 4.0 mm ² SCC plunger and anvil (3.10.2 Crimp the contact carrier)	70
Figure 3.48: Representation 4.0 mm ² SCC dimension D14 (3.10.2 Crimp the contact carrier)	71
Figure 3.49: Representation 4.0 mm ² SCC optional fixation of the cables (3.11 Optional fixation of the cables).....	72
Figure 3.50: Representation 4.0 mm ² SCC optional fixation of the cables max. 52.0 mm (3.11 Optional fixation of the cables).....	72
Figure 4.1: Representation 6.0 mm ² SCC cable example (4.1 Cutting the cable)	73
Figure 4.2: Representation 6.0 mm ² SCC dimension X1 and dimension D15 (4.1 Cutting the cable)	73
Figure 4.3: Representation 6.0 mm ² SCC assemble individual components (4.2 Assemble individual components).....	74
Figure 4.4: Representation 6.0 mm ² SCC pin assignment HPS40-2 2+2 cover cap 6.0 mm ² SCC polarized (4.2 Assemble individual components).....	74
Figure 4.5: Representation 6.0 mm ² SCC stripped off cable example (4.3 Strip off the cable).....	75
Figure 4.6: Representation 6.0 mm ² SCC dimension D16 (4.3 Strip off the cable)	75
Figure 4.7: Representation 6.0 mm ² SCC remove shielding foil (if present), trim shielding braid, and crimp the ferrule crimp (4.4 Remove shielding foil (if present), trim shielding braid, and assembly the stress relief and X-Ring)	76
Figure 4.8: Representation 6.0 mm ² SCC dimension D17 (4.4 Remove shielding foil (if present), trim shielding braid, and assembly the stress relief and X-Ring).....	76
Figure 4.9: Representation 6.0 mm ² SCC overhang shielding foil (4.4 Remove shielding foil (if present), trim shielding braid, and assembly the stress relief and X-Ring)	77
Figure 4.10: Representation 6.0 mm ² SCC assemble the stress relief (4.4 Remove shielding foil (if present), trim shielding braid, and assemble the stress relief and X-Ring)	77
Figure 4.11: Representation 6.0 mm ² SCC assemble the X-Ring (4.4 Remove shielding foil (if present), trim shielding braid, and assemble the stress relief and X-Ring)	77



Figure 4.12: Representation 6.0 mm ² SCC dimension D18 (4.4 Remove shielding foil (if present), trim shielding braid, and assemble the stress relief and X-Ring).....	78
Figure 4.13: Representation 6.0 mm ² SCC crimped HCT4 female terminal (4.5 Crimp the HCT4 female terminal)	79
Figure 4.14: Representation 6.0 mm ² SCC dimension D19, D20 and D21 (4.5 Crimp the HCT4 female terminal).....	79
Figure 4.15: Representation 6.0 mm ² SCC inserting into the contact carrier (4.6 Inserting HCT4 female terminals into contact carrier).....	80
Figure 4.16: Representation 6.0 mm ² SCC lead-in chamfers contact carrier (4.6 Inserting HCT4 female terminals into contact carrier).....	81
Figure 4.17: Representation 6.0 mm ² SCC plastic burr on contact carrier (4.6 Inserting HCT4 female terminals into contact carrier).....	82
Figure 4.18: Representation 6.0 mm ² SCC close secondary lock on the contact carrier (4.7 Close secondary lock on the contact carrier)	83
Figure 4.19: Representation 6.0 mm ² SCC pre-locking and locking position secondary lock (4.7 Close secondary lock on the contact carrier) ..	83
Figure 4.20: Representation 6.0 mm ² SCC slide the shielding sleeve onto the contact carrier (4.8 Slide the shielding sleeve onto the contact carrier).....	84
Figure 4.21: Representation 6.0 mm ² SCC risk of insulation failure (4.8 Slide the shielding sleeve onto the contact carrier)	84
Figure 4.22: Representation 6.0 mm ² SCC polarization shielding sleeve and contact carrier (4.8 Slide the shielding sleeve onto the contact carrier).....	84
Figure 4.23: Representation 6.0 mm ² SCC end position shielding sleeve on contact carrier (4.8 Slide the shielding sleeve onto the contact carrier).....	85
Figure 4.24: Representation 6.0 mm ² SCC protruded individual shielding strands (4.8 Slide the shielding sleeve onto the contact carrier).....	85
Figure 4.25: Representation 6.0 mm ² SCC X-ray analysis (4.8 Slide the shielding sleeve onto the contact carrier).....	85
Figure 4.26: Representation 6.0 mm ² SCC crimp the shielding sleeve (4.9 Crimp the shielding sleeve)	86
Figure 4.27: Representation 6.0 mm ² SCC shielding crimping and contact carrier crimping (4.9 Crimp the shielding sleeve)	86
Figure 4.28: Representation 6.0 mm ² SCC dimension D22 (4.9 Crimp the shielding sleeve)	87
Figure 4.29: Representation 6.0 mm ² SCC dimension D23 (4.9.1 Cable shielding crimping using two half-shells).....	88
Figure 4.30: Representation 6.0 mm ² SCC plunger and anvil Version B (4.9.1 Cable shielding crimping using two half-shells)	89
Figure 4.31: Representation 6.0 mm ² SCC width of measuring instrument for dimension D24 (4.9.1 Cable shielding crimping using two half-shells).....	90
Figure 4.32: Representation 6.0 mm ² SCC dimension D25 (4.9.1 Cable shielding crimping using two half-shells).....	91
Figure 4.33: Representation 6.0 mm ² SCC measurement area dimension D25 (4.9.1 Cable shielding crimping using two half-shells)	91
Figure 4.34: Representation 6.0 mm ² SCC dimension D24 and D25 (4.9.1 Cable shielding crimping using two half-shells).....	91
Figure 4.35: Representation 6.0 mm ² SCC pull-off force clamping position shielding sleeve (4.9.1 Cable shielding crimping using two half-shells)	92
Figure 4.36: Representation 6.0 mm ² SCC dimension D26 and embossing positions a-d (4.9.2 Crimp the contact carrier).....	93
Figure 4.37: Representation 6.0 mm ² SCC plunger and anvil (4.9.2 Crimp the contact carrier)	94
Figure 4.38: Representation 6.0 mm ² SCC dimension D27 (4.9.2 Crimp the contact carrier)	95
Figure 5.1: Representation 4.0 mm ² & 6.0 mm ² SCC assembling the locking sleeve (5.1 Assembling the locking sleeve)	96
Figure 5.2: Representation 4.0 mm ² & 6.0 mm ² SCC orientation contact carrier in locking sleeve (5.1 Assembling the locking sleeve)	96
Figure 5.3: Representation 4.0 mm ² & 6.0 mm ² SCC dimension D28 & D29 (5.1 Assembling the locking sleeve).....	97
Figure 5.4: Representation 4.0 mm ² & 6.0 mm ² SCC reference points contact carrier & locking sleeve (5.1 Assembling the locking sleeve)	97
Figure 5.5: Representation 4.0 mm ² & 6.0 mm ² SCC dimension DØ1 (5.1 Assembling the locking sleeve).....	98
Figure 5.6: Representation 4.0 mm ² & 6.0 mm ² SCC assemble the cable seal and cover cap into locking sleeve (5.2 Assemble the cable seal and cover cap).....	99
Figure 5.7: Representation 4.0 mm ² & 6.0 mm ² SCC assemble the cable seal into locking sleeve (5.2 Assemble the cable seal and cover cap).....	99
Figure 5.8: Representation 4.0 mm ² & 6.0 mm ² SCC assemble the cover cap into locking sleeve (5.2 Assemble the cable seal and cover cap)	100
Figure 5.9: Representation 4.0 mm ² & 6.0 mm ² SCC dimension D30 (5.2 Assemble the cable seal and cover cap)	100
Figure 6.1: Representation 4.0 mm ² & 6.0 mm ² SCC assemble the In-Line CPA cover onto locking sleeve (6.1 Assemble the In-Line CPA cover)	101
Figure 6.2: Representation 4.0 mm ² & 6.0 mm ² SCC dimension D31 (6.1 Assemble the In-Line CPA cover).....	102
Figure 6.3: Representation 4.0 mm ² & 6.0 mm ² SCC assemble the 90° angled cap onto locking sleeve (6.2 Assemble the 90° angled cap)	103



Figure 6.4: Representation 4.0 mm² & 6.0 mm² SCC assemble and close the 90° angled cap onto locking sleeve (6.2 Assemble the 90° angled cap) 103

Figure 6.5: Representation 4.0 mm² & 6.0 mm² SCC different orientations 90° angled cap (6.2 Assemble the 90° angled cap) 104

Figure 6.6: Representation 4.0 mm² & 6.0 mm² SCC assemble the coding clip onto cover cap (6.3 Assemble the coding clip on the cover cap) 106

Figure 6.7: Representation 4.0 mm² & 6.0 mm² SCC coding clip for 706-822-503 & 706-822-505 (6.3 Assemble the coding clip on the cover cap) 106

Figure 6.8: Representation 4.0 mm² & 6.0 mm² SCC coding clip for 706-430-504 & 706-430-505 (6.3 Assemble the coding clip on the cover cap) 107

Figure 6.9: Representation 4.0 mm² & 6.0 mm² SCC assemble the coding clip on the 90° angled cap (6.4 Assemble the coding clip on the 90° angled cap)..... 108

Figure 6.10: Representation 4.0 mm² & 6.0 mm² SCC coding clip for 90° angled cap (6.4 Assemble the coding clip on the 90° angled cap).... 108

Figure 6.11: Representation 4.0 mm² & 6.0 mm² SCC assemble the transport protection cap (6.5 Assemble the transport protection cap) 109



Figure 6.12: Representation 4.0 mm² & 6.0 mm² SCC assemble the transport protection cap onto the connector (6.5 Assemble the transport protection cap)..... 109

Figure 7.1: Representation 4.0 mm² & 6.0 mm² SCC manipulation of primary and secondary locking (7.4 Sample preparation for shielding retention force) 112

Figure 7.2: Representation 4.0 mm² & 6.0 mm² SCC removal of HCT4 female terminals after shielding crimping (7.4 Sample preparation for shielding retention force) 113



List of Abbreviations

BOM	Bill of material
D#	Dimension # (# stands for the consecutive number of the dimension specification, e.g., D0, D1, D2, ...)
DØ#	Dimension # (# stands for the consecutive number of the dimension specification, e.g., DØ0, DØ1, DØ2, ...)
F	Function (relevant in Chapter “1.7 Characteristics and customer approvals”)
HCT4	Hirschmann Automotive GmbH circuit terminal 4.0 mm
L	Legal (relevant in Chapter “1.7 Characteristics and customer approvals”)
mm	Millimeter
N	Newton
S	Safety (relevant in Chapter “1.7 Characteristics and customer approvals”)
SCC	Single core cable
X#	Customer Dimension # (# stands for the consecutive number of the dimension specification, e.g., X0, X1, X2, ...)
	Special characteristic (The relevant dimension is framed with this symbol in the figures)
	Functionally relevant dimension (The relevant dimension is framed with this symbol in the figures)



1 General

To ensure a successful assembly of the connector system, it is essential that our customers carefully review this processing specification. This chapter provides basic knowledge necessary for understanding and adhering to the standards defined in this specification. These standards are crucial for ensuring a smooth and effective assembly of the connector components.

1.1 Document

Please be aware that this document is currently not being updated or revised through a regular change service. As a result, all information in this edition is valid according to its current version, with no changes or updates having been made at this time. To ensure that you have access to the most recent information, we recommend consulting the current version of this document on our website www.hirschmann-automotive.com.

This document aims to establish precise processing requirements for the specified components. These requirements play a crucial role in quality assurance, product safety, and other relevant areas. By closely following the guidelines contained in this processing specification, it is ensured that the assembly of the product is carried out properly and functionally. This significantly contributes to the overall performance and reliability of the final product.



Careful handling of changes to the processing specification is essential. All adjustments or updates must be made with consideration of their potential impact on the processing process. It is the duty of the customer responsible for processing the products of Hirschmann Automotive GmbH to act promptly in the event of any changes to the specification. This includes ensuring that all affected employees are immediately and fully informed about the changes.

It is of utmost importance to strictly maintain the confidentiality of this document. The dissemination of any content to third parties without prior written consent is strictly prohibited. It is the customer's responsibility to ensure that all confidential information is adequately protected and accessible only to authorized persons.

To ensure clarity and consistency in communication, this document includes a glossary of abbreviations. In this glossary, special terms or abbreviations that are particularly significant in this context are listed with concise definitions or explanations. This is intended to ensure that all users of the document have a uniform and clear understanding of this technical terminology.



1.2 Processing

Customers processing products from Hirschmann Automotive GmbH bear a critical responsibility for correctly implementing the processing specification and adhering to the processing results set forth therein. A central aspect of this specification is the strict observance and accurate adherence to the prescribed dimensions, which are vital for the integrity, performance, and quality of the products, as well as other specified characteristics. Within the dimension specifications, we differentiate between special characteristics, which are specially marked with the symbol  in the respective illustrations and listed in **Chapter “1.7 Characteristics and customer approvals”**, and for which process capability must be demonstrated, functionally relevant dimensions, which are specially marked with the symbol  in the respective figures and determine the essential properties of the product such as performance, quality, and integrity, and auxiliary dimensions, which do not directly affect the core functions but are important for the correct assembly and overall construction. Precise adherence to both function-relevant and auxiliary dimensions is of the highest importance, as they collectively ensure that the products meet the defined standards and fulfill the specific requirements of their application. The function-relevant dimensions also contribute to the assurance of the auxiliary dimensions, thereby ensuring the overall consistency and reliability of the final product. As a result, while it may not be necessary to provide evidence of the auxiliary dimensions, we recommend verifying the function-relevant dimensions to ensure compliance with the central quality standards.

Throughout the entire processing process, it is of utmost importance that all individual components and assemblies are preserved in their original state and remain intact. Allowed signs of wear that cannot be prevented by certain process steps are explicitly mentioned in the respective process steps. The processor bears the responsibility for ensuring that the parts are not damaged. Not damaged in this context means that the components are free from any physical changes, deformations, breaks, scratches, or other impairments that could affect their function, integrity, or performance. They must remain in the condition in which they were delivered, without signs of wear, alteration, or interventions that could change their original specifications and properties. It is the processor's task to implement appropriate measures such as the use of additional equipment, providing work instructions, and conducting employee training to ensure damage-free processing. Although Hirschmann Automotive GmbH does not provide specific instructions on how to keep the components damage-free during processing, the design of the components is conceived in such a way that damage-free assembly is possible. Therefore, maintaining the integrity of all parts throughout the entire manufacturing process is essential for the overall quality of the final product, and the responsibility for this lies with the processor.

It is essential that the entire processing process, regardless of the manufacturer of the equipment, be independently validated and approved by the customer. This independent validation ensures that all specific requirements are met. Independence from external factors is crucial to give the customer complete control over the processing process. This guarantees that the established standards and quality specifications are not only met but also consistently adhered to. In this way, compliance with the highest quality standards is ensured, which is crucial for the integrity and reliability of the final product.



Ensuring that all employees involved in the processing process have the necessary training and qualifications is of critical importance. It is imperative that employees are capable of not only understanding the specific requirements of this specification but also implementing them precisely. This is essential to ensure the integrity and performance of the products from Hirschmann Automotive GmbH. Therefore, the customer responsible for processing these products must ensure that their employees are continuously trained and updated on the latest requirements. This ongoing qualification of employees is a critical factor in ensuring compliance with the highest quality and performance standards.

The assertion of warranty and liability claims by the customer against Hirschmann Automotive GmbH is strictly bound to the contractual provisions. This means that any claims are only valid under the condition that the specified processing guidelines are precisely followed. Should there be improper processing or deviation from the specifications by the customer, Hirschmann Automotive GmbH reserves the right to reject any complaints under these circumstances. This regulation emphasizes the importance of strict adherence to all established processing directives, as deviation from them can affect the customer's warranty and liability claims.

It is the customer's responsibility to strictly adhere to the established processing process. Should there be deviations from this process, the customer fully assumes responsibility for validating the product quality. In such cases, it is necessary for the customer to clarify these deviations and their effects directly and promptly with the respective OEM. This means that the customer must independently ensure that the product meets the quality requirements and specifications of the OEM despite the deviations. Communication with the OEM is crucial to identify potential problems and develop solutions that ensure compliance with the required standards.



1.3 Equipment

The manufacturers of equipment and fixtures listed in this processing specification are to be understood as recommendations and are therefore not binding. These recommendations are merely to indicate that the described processing results have been determined, validated, and approved using equipment from these specific manufacturers. It is important to emphasize that Hirschmann Automotive GmbH does not make binding specifications regarding the selection of certain manufacturers. Customers are free to use equipment and fixtures from manufacturers of their choice, as long as the required processing results are achieved, and the specifications are adhered to. This flexibility allows customers to choose resources that meet their specific requirements and preferences, while still meeting the quality standards and performance objectives.

Customers have the option of not limiting themselves exclusively to the manufacturers recommended by Hirschmann Automotive GmbH when selecting equipment and fixtures for processing. Instead, they are encouraged to choose the operating resources that are optimal for their specific processing process. The key factor here is that the specified requirements and quality standards are met without restriction. Hirschmann Automotive GmbH supports this flexibility and promotes the individual selection of operating resources that contribute to increased efficiency, quality assurance, and meeting the specific needs of the customer.

If customers decide to use alternative manufacturers for equipment and fixtures, it is necessary for them to conduct a thorough qualification and validation of these operating resources. It is crucial that these alternative equipment and fixtures meet the standards set by Hirschmann Automotive GmbH and are capable of delivering equivalent processing results. Customers are urged to ensure that the alternative operating resources provide adequate performance and meet the required quality and performance criteria. These steps are essential to ensure the integrity of the processing process and the quality of the final product.

In **Chapter “8 Appendix”** of this document, you will find a detailed listing of all used equipment and fixtures, along with the corresponding manufacturer information. This directory serves not only as a comprehensive overview of the operating resources utilized but also contains specific information on the relevant processing steps pertinent to each piece of equipment and fixture. The information provided is intended to offer clear guidance and ensure the correct application of the various operating resources in the processing process.



1.4 Process parameters

Hirschmann Automotive GmbH focuses in the processing specification on the technically required outcome of the process, rather than prescribing specific process parameters such as welding currents, welding times, or crimping forces. The specification clearly defines the required technical end results that are crucial for compliance with product specifications. These include, for instance, the exact geometry of the welding nodes, the minimal required pull-off forces, and precise length measurements. These guidelines ensure that the final product meets the high-quality standards of Hirschmann Automotive GmbH and fully satisfies the specific requirements of the product specification.

For flexible components and cables, all length specifications in the processing specification are to be interpreted as extended lengths. It is crucial that no loads are applied to the components during the measurement of these dimensions. Any form of load could lead to damages or other impairments that would distort the accuracy and validity of the measurement results. Careful measurement without load ensures that the recorded values are a reliable and accurate representation of the actual properties of the components. This is essential to ensure compliance with the established requirements in the processing specification and to maintain the integrity of the final product.

For customers, it is essential to validate the relevant process parameters according to the requirements in the processing specification. This validation ensures that the selected parameters achieve the desired technical results and thus ensure compliance with the processing specifications. Customers should verify whether the parameters lead to the defined technical characteristics of the final product. These steps are crucial to guarantee compliance with the established quality standards and specifications, thereby ensuring the integrity and performance of the product.

We strongly recommend meticulously documenting all process parameters in the processing process. Such documentation is crucial for ensuring complete traceability. This not only allows for the verification of compliance with the set guidelines but also ensures transparency in all processing steps. Accurate recording of the process parameters facilitates the identification and analysis of potential problems and contributes significantly to quality assurance. Furthermore, in the event of deviations or errors, quick and effective action can be taken, as the relevant data are available for immediate correction and optimization of the process.



1.5 Purpose

This chapter describes the purpose of the EVS-100111. This processing specification applies to all variants listed in “**Table 1.1**” and describes the structure as well as the processing of the HPS40-2 2+2 female connector 4.0 mm² SCC and the HPS40-2 2+2 female connector 6.0 mm² SCC. The numbers listed in “**Table 1.1**” are system drawing numbers and are not intended as order numbers. All approved and to be used components are detailed in the system drawings. Additionally, there are OEM-specific system drawings based on the numbers listed in “**Table 1.1**”. These OEM-specific system drawings can be provided upon request.

Table 1.1: Overview product variants (1.5 Purpose)

System number	Coding	Cable cross section
807-655-501	A	4.0 mm ² 6.0 mm ²
807-655-502	B	
807-655-503	C	
807-655-504	D	
807-655-507	Z	
809-887-001	A	4.0 mm ²
809-887-003	A	6.0 mm ²



1.6 Additionally documents

This chapter describes additional relevant documents that are listed in this processing specification. These documents, such as additional processing specifications and datasheets for approved cables, are shown in „**Table 1.2**“.

Table 1.2: Overview additionally relevant documents (1.6 Additionally relevant documents)

A	HCT4 Process specification (Ag)	EVS-100068
B	Cable datasheet Huber & Suhner SCC 4.0mm ² FHLR91XC13X-1x4 T150	Huber & Suhner Order No.: 12582674
C	Cable datasheet Coficab SCC 4.0mm ² FHLR91XCB91X T4 PSA	Coficab Order No.: H4XCBX04HHHH
D	Cable datasheet Coroflex SCC 4.0mm ² FHLR2GCB2G 4.0 mm ² / 0.21 T180	Coroflex Order No.: 9-2611 / 4.0 mm ²
F	Cable datasheet Leoni SCC 4.0mm ² FHLR2GCB2G 4,0/0,31/T180	Leoni Order No.: FHLR2GCB2G 00003
G	Cable datasheet Coficab SCC 6.0mm ² FHLR91XCB91X T4	Coficab Order No.: H4XCBX06xxyy
H	Cable datasheet Coroflex SCC 6.0mm ² FHLR2GCB2G 6.0 mm ² / 0.21 T180	Coroflex Order No.: 9-2611 / 6.0 mm ²
I	Cable datasheet Kroschu SCC 6.0mm ² FHLR2GCB2G 6.00 QMM/0.21/T180	Kroschu Order No.: 64998762
J	Cable datasheet Leoni SCC 6.0mm ² FHLR2GCB2G 6,0/0,31/T180	Leoni Order No.: FHLR2GCB2G 00004
K	Cable datasheet Gebauer & Griller SCC 6.0mm ² FHLALR2GCB2G 1X6.0(0.40)/T180	Gebauer & Griller Order No.: 167785
L	HCT4 Process specification (Al)	EVS-100145
M	Cable datasheet Coficab SCC 6.0mm ² FHLR91XC91X T4 ISO	Coficab Order No.: HI4XCXB06HHH
N	Cable datasheet Gebauer & Griller SCC 6.0mm ² FHLR2GCB2G 1x6.0/T180 OR	Gebauer & Griller Order No.: FHLR2GCB2G 1x6.0/T180 OR
O	Cable datasheet Gebauer & Griller SCC 4.0mm ² FHLR2GCB2G 1x4.0/T180 OR	Gebauer & Griller Order No.: FHLR2GCB2G 1x4.0/T180 OR
P	Cable datasheet Aptiv SCC 6.0mm ² FHLR91XC91X-C 6.0 mm ²	Aptiv Order No.: M8979G FHLR91XC91X-C 6.0 mm ²
Q	Cable datasheet Aptiv SCC 4.0mm ² FHLR91XC91X-B 4.0 mm ²	Aptiv Order No. M9031E FHLR91XC91X-B 4.0 mm ²



1.7 Characteristics and customer approvals

It is of utmost importance to carefully monitor the special characteristics listed below during the processing, as they cover legal, safety-related, and functional aspects. Strict adherence to these OEM-specific characteristics is crucial. Additional functional characteristics should be carried out in coordination and definition with the OEM.

1.7.1 Customer: Miscellaneous

The specific characteristics listed in “**Table 1.3**” are applicable starting with the version 26 (08/2023). For applications before this date, strict compliance with these specific characteristics is not mandatory.

Table 1.3: Overview characteristics for customer miscellaneous (1.7 Characteristics and customer approvals)

Customer: Miscellaneous						
1	2	3	Characteristic	Specific purpose	Location of implementation	Listed in Chapter
L1	-	-	D11 and D24 height of shielding crimping	Strain-relief, electrical shielding connection - EMC	Tier 1	3.10.1 4.9.1
L2**	-	-	Retention force of shielding crimping	Strain-relief, electrical shielding connection - EMC		3.10.1 4.9.1
-	-	F1	D28 depth of contact carrier	Pluggability		5.1

**A 100% inspection is not possible as the test specimens are destroyed during the examination. The verification of capability or the continuous testing of all specific characteristics needs to be coordinated directly with the OEM.



1.7.2 Customer: BMW

The specific characteristics listed in “**Table 1.4**” are applicable starting with the version 23 (10/2022). For applications before this date, strict compliance with these specific characteristics is not mandatory.

Table 1.4: Overview characteristics for customer BMW (1.7 Characteristics and customer approvals)

Customer: BMW BMW-Number: 5 A37 9F8			NAEL:	E 24550 –VS16 E 1E24 A –VS18 E 3S65 A –VS21 N OU53 B –VS23		
Special characteristics according to GS 91011:2019-8						
L	S	F	Characteristic	Specific purpose	Location of implementation	Listed in Chapter
L1	-	-	D11 and D24 height of shielding crimping	Strain-relief, electrical shielding connection - EMC	Tier 1	3.10.1 4.9.1
L2**	-	-	Retention force of shielding crimping	Strain-relief, electrical shielding connection - EMC		3.10.1 4.9.1
-	-	F1	D28 depth of contact carrier	Pluggability		5.1

**A 100% inspection is not possible as the test specimens are destroyed during the examination. The verification of capability or the continuous testing of all specific characteristics needs to be coordinated directly with the OEM.



2 Product structure

This chapter provides a comprehensive overview of the product structure. It includes OEM-specific bill of materials and a detailed description of all individual components necessary for the assembly of the connector system. Additionally, all approved cables are presented to ensure a complete overview of the authorized components and the overall assembly.

2.1 Bill of materials

In this chapter, the OEM-specific bill of materials is provided. These lists are based on system numbers, possible OEM-specific numbers, and the corresponding individual components. The quantity of individual components per connector system is also detailed to provide a clear overview of the required parts.

2.1.1 HPS40-2 2+2 female connector SCC 4.0 mm² with HVIL

In this chapter, all OEM-specific bill of materials for the HPS40-2 2+2 female connector SCC 4.0 mm² with HVIL are presented.

2.1.1.1 Customer: Miscellaneous

Table 2.1: Overview BOM HPS40-2 2+2 female connector SCC 4.0 mm² with HVIL, Customer: Miscellaneous (2.1 Bill of materials)

Hirschmann Automotive GmbH system number		807-655-501	807-655-502	807-655-503	807-655-504	807-655-507
Customer specific number		807-655-501	807-655-502	807-655-503	807-655-504	807-655-507
Article description	Article number	Quantity per connector system				
HPS40-2 2+2 locking sleeve	807-656-501	1	1	1	1	1
HPS40-2 2+2 female contact carrier cod. A with HVIL	807-657-541	1	-	-	-	-
HPS40-2 2+2 female contact carrier cod. B with HVIL	807-657-542	-	1	-	-	-
HPS40-2 2+2 female contact carrier cod. C with HVIL	807-657-543	-	-	1	-	-
HPS40-2 2+2 female contact carrier cod. D with HVIL	807-657-544	-	-	-	1	-
HPS40-2 2+2 female contact carrier cod. Z with HVIL	807-657-547	-	-	-	-	1
HPS40-2 2+2 shielding sleeve 4.0 mm ² SCC	710-161-504	1	1	1	1	1
HPS40-2 2+2 ferrule crimp 4.0 mm ² SCC	710-195-502	2	2	2	2	2
HPS40-2 2+2 cable seal 4.0 mm ² SCC	709-972-502	1	1	1	1	1
HPS40-2 2+2 cover cap 4.0 mm ² SCC non-polarized	706-822-503	1	1	1	1	1
HCT4 female terminal 4.0 mm ²	709-427-504	2	2	2	2	2



2.1.1.2 Customer: BMW

Table 2.2: Overview BOM HPS40-2 2+2 female connector SCC 4.0 mm² with HVIL, Customer: BMW (2.1 Bill of materials)

Hirschmann Automotive GmbH system number	807-655-501	807-655-502	807-655-503	807-655-504	807-655-507	
Customer specific number	6 812 909.1 - Sheet 05					
Article description	Article number	Quantity per connector system				
HPS40-2 2+2 locking sleeve	807-656-511	1	1	1	1	1
HPS40-2 2+2 female contact carrier cod. A with HVIL	807-657-541	1	-	-	-	-
HPS40-2 2+2 female contact carrier cod. B with HVIL	807-657-542	-	1	-	-	-
HPS40-2 2+2 female contact carrier cod. C with HVIL	807-657-543	-	-	1	-	-
HPS40-2 2+2 female contact carrier cod. D with HVIL	807-657-544	-	-	-	1	-
HPS40-2 2+2 female contact carrier cod. Z with HVIL	807-657-547	-	-	-	-	1
HPS40-2 2+2 shielding sleeve 4.0 mm ² SCC	710-161-504	1	1	1	1	1
HPS40-2 2+2 ferrule crimp 4.0 mm ² SCC	710-195-502	2	2	2	2	2
HPS40-2 2+2 cable seal 4.0 mm ² SCC	709-972-502	1	1	1	1	1
HPS40-2 2+2 cover cap 4.0 mm ² SCC polarized	706-430-504	1	1	1	1	1
HCT4 female terminal 4.0 mm ²	709-427-504	2	2	2	2	2

2.1.1.3 Customer: Stellantis

Table 2.3: Overview BOM HPS40-2 2+2 female connector SCC 4.0 mm² with HVIL, Customer: Stellantis (2.1 Bill of materials)

Hirschmann Automotive GmbH system number	809-887-001	-	-
Customer specific number	809-887-001	-	-
Article description	Article number	Quantity per connector system	
HPS40-2 2+2 locking sleeve	807-656-541	1	-
HPS40-2 2+2 female contact carrier cod. A with HVIL	807-657-541	1	-
HPS40-2 2+2 shielding sleeve 4.0 mm ² SCC	710-161-504	1	-
HPS40-2 2+2 ferrule crimp 4.0 mm ² SCC	710-195-502	2	-
HPS40-2 2+2 cable seal 4.0 mm ² SCC	709-972-502	1	-
HPS40-2 2+2 cover cap 4.0 mm ² SCC non-polarized	706-822-503	1	-
HCT4 female terminal 4.0 mm ²	709-427-504	2	-



2.1.2 HPS40-2 2+2 female connector SCC 4.0 mm² without HVIL

In this chapter, all OEM-specific bill of materials for the HPS40-2 2+2 female connector SCC 4.0 mm² without HVIL are presented.

2.1.2.1 Customer: Miscellaneous

Table 2.4: Overview BOM HPS40-2 2+2 female connector SCC 4.0 mm² without HVIL, Customer: Miscellaneous (2.1 Bill of materials)

Hirschmann Automotive GmbH system number		807-655-501	807-655-502	807-655-503	807-655-504	807-655-507
Customer specific number		807-655-501	807-655-502	807-655-503	807-655-504	807-655-507
Article description	Article number	Quantity per connector system				
HPS40-2 2+2 locking sleeve	807-656-501	1	1	1	1	1
HPS40-2 2+2 female contact carrier cod. A without HVIL	807-657-561	1	-	-	-	-
HPS40-2 2+2 female contact carrier cod. B without HVIL	807-657-562	-	1	-	-	-
HPS40-2 2+2 female contact carrier cod. C without HVIL	807-657-563	-	-	1	-	-
HPS40-2 2+2 female contact carrier cod. D without HVIL	807-657-564	-	-	-	1	-
HPS40-2 2+2 female contact carrier cod. Z without HVIL	807-657-567	-	-	-	-	1
HPS40-2 2+2 shielding sleeve 4.0 mm ² SCC	710-161-504	1	1	1	1	1
HPS40-2 2+2 ferrule crimp 4.0 mm ² SCC	710-195-502	2	2	2	2	2
HPS40-2 2+2 cable seal 4.0 mm ² SCC	709-972-502	1	1	1	1	1
HPS40-2 2+2 cover cap 4.0 mm ² SCC non-polarized	706-822-503	1	1	1	1	1
HCT4 female terminal 4.0 mm ²	709-427-504	2	2	2	2	2



2.1.2.2 Customer: BMW

Table 2.5: Overview BOM HPS40-2 2+2 female connector SCC 4.0 mm² without HVIL, Customer: BMW (2.1 Bill of materials)

Hirschmann Automotive GmbH system number		807-655-501	807-655-502	807-655-503	807-655-504	807-655-507
Customer specific number	6 812 909.1 - Sheet 05					
Article description	Article number	Quantity per connector system				
HPS40-2 2+2 locking sleeve	807-656-511	1	1	1	1	1
HPS40-2 2+2 female contact carrier cod. A without HVIL	807-657-561	1	-	-	-	-
HPS40-2 2+2 female contact carrier cod. B without HVIL	807-657-562	-	1	-	-	-
HPS40-2 2+2 female contact carrier cod. C without HVIL	807-657-563	-	-	1	-	-
HPS40-2 2+2 female contact carrier cod. D without HVIL	807-657-564	-	-	-	1	-
HPS40-2 2+2 female contact carrier cod. Z without HVIL	807-657-567	-	-	-	-	1
HPS40-2 2+2 shielding sleeve 4.0 mm ² SCC	710-161-504	1	1	1	1	1
HPS40-2 2+2 ferrule crimp 4.0 mm ² SCC	710-195-502	2	2	2	2	2
HPS40-2 2+2 cable seal 4.0 mm ² SCC	709-972-502	1	1	1	1	1
HPS40-2 2+2 cover cap 4.0 mm ² SCC polarized	706-430-504	1	1	1	1	1
HCT4 female terminal 4.0 mm ²	709-427-504	2	2	2	2	2



2.1.3 HPS40-2 2+2 female connector SCC 6.0 mm² with HVIL

In this chapter, all OEM-specific bill of materials for the HPS40-2 2+2 female connector SCC 6.0 mm² with HVIL are presented.

2.1.3.1 Customer: Miscellaneous

Table 2.6: Overview BOM HPS40-2 2+2 female connector SCC 6.0 mm² with HVIL, Customer: Miscellaneous (2.1 Bill of materials)

Hirschmann Automotive GmbH system number		807-655-501	807-655-502	807-655-503	807-655-504	807-655-507
Customer specific number		807-655-501	807-655-502	807-655-503	807-655-504	807-655-507
Article description	Article number	Quantity per connector system				
HPS40-2 2+2 locking sleeve	807-656-501	1	1	1	1	1
HPS40-2 2+2 female contact carrier cod. A with HVIL	807-657-541	1	-	-	-	-
HPS40-2 2+2 female contact carrier cod. B with HVIL	807-657-542	-	1	-	-	-
HPS40-2 2+2 female contact carrier cod. C with HVIL	807-657-543	-	-	1	-	-
HPS40-2 2+2 female contact carrier cod. D with HVIL	807-657-544	-	-	-	1	-
HPS40-2 2+2 female contact carrier cod. Z with HVIL	807-657-547	-	-	-	-	1
HPS40-2 2+2 shielding sleeve 6.0 mm ² SCC	710-161-506	1	1	1	1	1
HPS40-2 2+2 stress relief 6.0 mm ² SCC	710-671-501	2	2	2	2	2
HPS40-2 2+2 X-Ring 6.0 mm ² SCC	710-675-501	2	2	2	2	2
HPS40-2 2+2 cable seal 6.0 mm ² SCC	709-972-504	1	1	1	1	1
HPS40-2 2+2 cover cap 6.0 mm ² SCC non-polarized	706-822-505	1	1	1	1	1
HCT4 female terminal 6.0 mm ²	709-427-505	2	2	2	2	2



2.1.3.2 Customer: BMW

Table 2.7: Overview BOM HPS40-2 2+2 female connector SCC 6.0 mm² with HVIL, Customer: BMW (2.1 Bill of materials)

Hirschmann Automotive GmbH system number	807-655-501	807-655-502	807-655-503	807-655-504	807-655-507	
Customer specific number	6 812 909.1 - Sheet 05					
Article description	Article number	Quantity per connector system				
HPS40-2 2+2 locking sleeve	807-656-511	1	1	1	1	1
HPS40-2 2+2 female contact carrier cod. A with HVIL	807-657-541	1	-	-	-	-
HPS40-2 2+2 female contact carrier cod. B with HVIL	807-657-542	-	1	-	-	-
HPS40-2 2+2 female contact carrier cod. C with HVIL	807-657-543	-	-	1	-	-
HPS40-2 2+2 female contact carrier cod. D with HVIL	807-657-544	-	-	-	1	-
HPS40-2 2+2 female contact carrier cod. Z with HVIL	807-657-547	-	-	-	-	1
HPS40-2 2+2 shielding sleeve 6.0 mm ² SCC	710-161-506	1	1	1	1	1
HPS40-2 2+2 stress relief 6.0 mm ² SCC	710-671-501	2	2	2	2	2
HPS40-2 2+2 X-Ring 6.0 mm ² SCC	710-675-501	2	2	2	2	2
HPS40-2 2+2 cable seal 6.0 mm ² SCC	709-972-504	1	1	1	1	1
HPS40-2 2+2 cover cap 6.0 mm ² SCC polarized	706-430-505	1	1	1	1	1
HCT4 female terminal 6.0 mm ²	709-427-505	2	2	2	2	2

2.1.3.3 Customer: Stellantis

Table 2.8: Overview BOM HPS40-2 2+2 female connector SCC 6.0 mm² with HVIL, Customer: Stellantis (2.1 Bill of materials)

Hirschmann Automotive GmbH system number	809-887-003	-	-
Customer specific number	809-887-003	-	-
Article description	Article number	Quantity per connector system	
HPS40-2 2+2 locking sleeve	807-656-541	1	-
HPS40-2 2+2 female contact carrier cod. A with HVIL	807-657-541	1	-
HPS40-2 2+2 shielding sleeve 6.0 mm ² SCC	710-161-506	1	-
HPS40-2 2+2 stress relief 6.0 mm ² SCC	710-671-501	2	-
HPS40-2 2+2 X-Ring 6.0 mm ² SCC	710-675-501	2	-
HPS40-2 2+2 cable seal 4.0 mm ² SCC	709-972-502	1	-
HPS40-2 2+2 cover cap 4.0 mm ² SCC non-polarized	706-822-503	1	-
HCT4 female terminal 6.0 mm ²	709-427-505	2	-



2.1.4 HPS40-2 2+2 female connector SCC 6.0 mm² without HVIL

In this chapter, all OEM-specific bill of materials for the HPS40-2 2+2 female connector SCC 6.0 mm² without HVIL are presented.

2.1.4.1 Customer: Miscellaneous

Table 2.9: Overview BOM HPS40-2 2+2 female connector SCC 6.0 mm² without HVIL, Customer: Miscellaneous (2.1 Bill of materials)

Hirschmann Automotive GmbH system number		807-655-501	807-655-502	807-655-503	807-655-504	807-655-507
Customer specific number		807-655-501	807-655-502	807-655-503	807-655-504	807-655-507
Article description	Article number	Quantity per connector system				
HPS40-2 2+2 locking sleeve	807-656-501	1	1	1	1	1
HPS40-2 2+2 female contact carrier cod. A without HVIL	807-657-561	1	-	-	-	-
HPS40-2 2+2 female contact carrier cod. B without HVIL	807-657-562	-	1	-	-	-
HPS40-2 2+2 female contact carrier cod. C without HVIL	807-657-563	-	-	1	-	-
HPS40-2 2+2 female contact carrier cod. D without HVIL	807-657-564	-	-	-	1	-
HPS40-2 2+2 female contact carrier cod. Z without HVIL	807-657-567	-	-	-	-	1
HPS40-2 2+2 shielding sleeve 6.0 mm ² SCC	710-161-506	1	1	1	1	1
HPS40-2 2+2 stress relief 6.0 mm ² SCC	710-671-501	2	2	2	2	2
HPS40-2 2+2 X-Ring 6.0 mm ² SCC	710-675-501	2	2	2	2	2
HPS40-2 2+2 cable seal 6.0 mm ² SCC	709-972-504	1	1	1	1	1
HPS40-2 2+2 cover cap 6.0 mm ² SCC non-polarized	706-822-505	1	1	1	1	1
HCT4 female terminal 6.0 mm ²	709-427-505	2	2	2	2	2



2.1.4.2 Customer: BMW

Table 2.10: Overview BOM HPS40-2 2+2 female connector SCC 6.0 mm² without HVIL, Customer: BMW (2.1 Bill of materials)

Hirschmann Automotive GmbH system number		807-655-501	807-655-502	807-655-503	807-655-504	807-655-507
Customer specific number		6 812 909.1 - Sheet 05				
Article description	Article number	Quantity per connector system				
HPS40-2 2+2 locking sleeve	807-656-511	1	1	1	1	1
HPS40-2 2+2 female contact carrier cod. A without HVIL	807-657-561	1	-	-	-	-
HPS40-2 2+2 female contact carrier cod. B without HVIL	807-657-562	-	1	-	-	-
HPS40-2 2+2 female contact carrier cod. C without HVIL	807-657-563	-	-	1	-	-
HPS40-2 2+2 female contact carrier cod. D without HVIL	807-657-564	-	-	-	1	-
HPS40-2 2+2 female contact carrier cod. Z without HVIL	807-657-567	-	-	-	-	1
HPS40-2 2+2 shielding sleeve 6.0 mm ² SCC	710-161-506	1	1	1	1	1
HPS40-2 2+2 stress relief 6.0 mm ² SCC	710-671-501	2	2	2	2	2
HPS40-2 2+2 X-Ring 6.0 mm ² SCC	710-675-501	2	2	2	2	2
HPS40-2 2+2 cable seal 6.0 mm ² SCC	709-972-504	1	1	1	1	1
HPS40-2 2+2 cover cap 6.0 mm ² SCC polarized	706-430-505	1	1	1	1	1
HCT4 female terminal 6.0 mm ²	709-427-505	2	2	2	2	2



2.2 Approved cables

In this chapter, the exclusively approved cables for the product are described. Only cables listed here and approved by the respective OEM for the product are permitted. Specific details regarding OEM-specific approved cables are meticulously documented in the OEM-specific drawings and can be referenced from there.

2.2.1 Single core cables 4.0 mm²

In this chapter, all approved single core cables with a cross section of 4.0 mm² are described. The overview of these cables is presented in "**Table 2.11**".

Table 2.11: Overview approved SCC 4.0 mm² (2.2 Approved cables)

Cable manufacturer	Cable type	Production location	According Chapter 1.6
Coficab	FHLR91XCB91X T4 PSA	Portugal, 6300-230 Guarda	C
Coroflex	FHLR2GCB2G 4.0 mm ² / 0.21 T180	Germany, 42279 Wuppertal	D
Gebauer & Griller	FHLR2GCB2G 1x4.0/T180 OR	Austria, 2170 Poysdorf	O
Huber & Suhner	FHLR91XC13X-1x4 T150	Switzerland, 8330 Pfäffikon	B
Leoni	FHLR2GCB2G 4,0/0,31/T180	Italy, 29010 Monticelli	F
Aptiv	FHLR91XC91X-B 4.0mm ²	Poland, 34-340 Jelesnia Portugal, 6001-900 Castelo Branco	Q



2.2.2 Single core cables 6.0 mm²

In this chapter, all approved single core cables with a cross section of 6.0 mm² are described. The overview of these cables is presented in “**Table 2.12**”.

Table 2.12: Overview approved SCC 6.0 mm² (2.2 Approved cables)

Cable manufacturer	Cable type	Production location	According Chapter 1.6
Coficab	FHLR91XCB91X T4	Portugal, 6300-230 Guarda	G
Coficab	FHLR91XC91X T4 ISO (1*)	Portugal, 6300-230 Guarda	M
Coroflex	FHLR2GCB2G 6.0 mm ² / 0.21 T180	Germany, 42279 Wuppertal	H
Gebauer & Griller	FHLR2GCB2G 1x6.0/T180 OR	Austria, 2170 Poysdorf	N
Gebauer & Griller	FHLALR2GCB2G 1X6.0(0.40)/T180 (2*)	Austria, 2170 Poysdorf	K
Kroschu	FHLR2GCB2G 6.00 QMM/0.21/T180	Germany, 46414 Rhede	I
Leoni	FHLR2GCB2G 6,0/0,31/T180	Italy, 29010 Monticelli	J
Aptiv	FHLR91XC91X-C (3*) 6.0 mm ²	Poland, 34-340 Jelesnia Portugal, 6001-900 Castelo Branco	P

(1*) The products utilizing the Coficab FHLR91XC91X ISO T4 6.0 mm² cable must employ the HPS40-2 2+2 cable seal 4.0 mm² SCC (709-972-502) mentioned in “**Table 2.20**” and the HPS40-2 2+2 cover cap 4.0 mm² SCC non-polarized (706-882-503) mentioned in “**Table 2.21**”.

(2*) If the product utilizes the Gebauer & Griller FHLALR2GCB2G 1X6,0(0,40)/T180 cable, special processing steps and responsibilities apply. Please refer to the Appendix for Alu wiring EVS-100111-A1.

(3*) The products utilizing the Aptiv FHLR91XC91X-C 6.0 mm² cable must employ the HPS40-2 2+2 cable seal 4.0 mm² SCC (709-972-502) mentioned in “**Table 2.20**” and the HPS40-2 2+2 cover cap 4.0 mm² SCC non-polarized (706-882-503) mentioned in “**Table 2.21**”.

2.3 Article representation

In this chapter, all individual components required for assembly are detailed. The approved items for each respective OEM are indicated on the OEM-specific drawings. The item overview always includes neutral drawings unless it is an OEM-specific item. For OEM-specific items, OEM-specific drawings can be provided upon request, listing the approved items for the specific OEM.

If an item is OEM-specific, it is appropriately marked with the relevant OEM in the item overview and may only be used for that OEM. Non-OEM-specific items have no markings in the item overview and can be used for all other OEMs, except those already mentioned.

Due to the variety of cables that may have different cable dimensions, a specific selection of individual items may be required in certain cases. These differences are documented in the process specification in **Chapter “2.2 Approved cables”**.

2.3.1 HPS40-2 2+2 locking sleeve

Figure 2.1: Representation HPS40-2 2+2 locking sleeve (2.3 Article representation)



	
<p>807-656-501 807-656-511</p>	<p>807-656-503</p>

Table 2.13: Overview HPS40-2 2+2 locking sleeve (2.3 Article representation)

Article description	Article number	Drawing number	OEM-specific article
HPS40-2 2+2 locking sleeve	807-656-501	807-656-...00	-
HPS40-2 2+2 locking sleeve	807-656-511	807-655-...02	BMW
HPS40-2 2+2 locking sleeve NAFTA	807-656-503	807-656-...00	-
HPS40-2 2+2 locking sleeve	807-656-541	807-656-...00	Stellantis

Delivery condition: The locking sleeves are delivered as bulk goods.

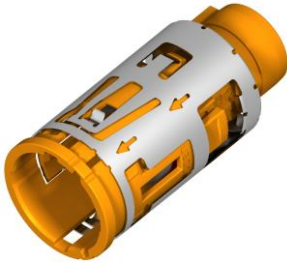

2.3.2 HPS40-2 2+2 female contact carrier 4.0 mm²

Figure 2.2: Representation HPS40-2 2+2 female contact carrier 4.0 mm² (2.3 Article representation)





				
807-657-501 807-657-508	807-657-502 807-657-509	807-657-503 807-657-510	807-657-504 807-657-511	807-657-507 807-657-514

Table 2.14: Overview HPS40-2 2+2 female contact carrier 4.0 mm² (2.3 Article representation)

Article description	Article number	Drawing number	OEM-specific article
HPS40-2 2+2 female contact carrier cod. A with HVIL	807-657-501	807-657-...00	-
HPS40-2 2+2 female contact carrier cod. B with HVIL	807-657-502	807-657-...00	-
HPS40-2 2+2 female contact carrier cod. C with HVIL	807-657-503	807-657-...00	-
HPS40-2 2+2 female contact carrier cod. D with HVIL	807-657-504	807-657-...00	-
HPS40-2 2+2 female contact carrier cod. Z with HVIL	807-657-507	807-657-...00	-
HPS40-2 2+2 female contact carrier cod. A without HVIL	807-657-508	807-657-...00	-
HPS40-2 2+2 female contact carrier cod. B without HVIL	807-657-509	807-657-...00	-
HPS40-2 2+2 female contact carrier cod. C without HVIL	807-657-510	807-657-...00	-
HPS40-2 2+2 female contact carrier cod. D without HVIL	807-657-511	807-657-...00	-
HPS40-2 2+2 female contact carrier cod. Z without HVIL	807-657-514	807-657-...00	-

Delivery condition: The contact carriers are delivered as bulk goods.

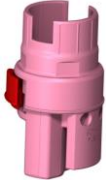

2.3.3 HPS40-2 2+2 female contact carrier 4.0 mm² & 6.0 mm² SCC

Figure 2.3: Representation HPS40-2 2+2 female contact carrier 4.0 mm² & 6.0 mm² SCC (2.3 Article representation)





				
807-657-541 807-657-561	807-657-542 807-657-562	807-657-543 807-657-563	807-657-544 807-657-564	807-657-547 807-657-567

Table 2.15: Overview HPS40-2 2+2 female contact carrier 4.0 mm² & 6.0 mm² SCC (2.3 Article representation)

Article description	Article number	Drawing number	OEM-specific article
HPS40-2 2+2 female contact carrier cod. A with HVIL	807-657-541	807-657-...00	-
HPS40-2 2+2 female contact carrier cod. B with HVIL	807-657-542	807-657-...00	-
HPS40-2 2+2 female contact carrier cod. C with HVIL	807-657-543	807-657-...00	-
HPS40-2 2+2 female contact carrier cod. D with HVIL	807-657-544	807-657-...00	-
HPS40-2 2+2 female contact carrier cod. Z with HVIL	807-657-547	807-657-...00	-
HPS40-2 2+2 female contact carrier cod. A without HVIL	807-657-561	807-657-...00	-
HPS40-2 2+2 female contact carrier cod. B without HVIL	807-657-562	807-657-...00	-
HPS40-2 2+2 female contact carrier cod. C without HVIL	807-657-563	807-657-...00	-
HPS40-2 2+2 female contact carrier cod. D without HVIL	807-657-564	807-657-...00	-
HPS40-2 2+2 female contact carrier cod. Z without HVIL	807-657-567	807-657-...00	-

Delivery condition: The contact carriers are delivered as bulk goods.



2.3.4 HPS40-2 2+2 shielding sleeve 4.0 mm² & 6.0 mm² SCC

Figure 2.4: Representation HPS40-2 2+2 shielding sleeve 4.0 mm² & 6.0 mm² SCC (2.3 Article representation)

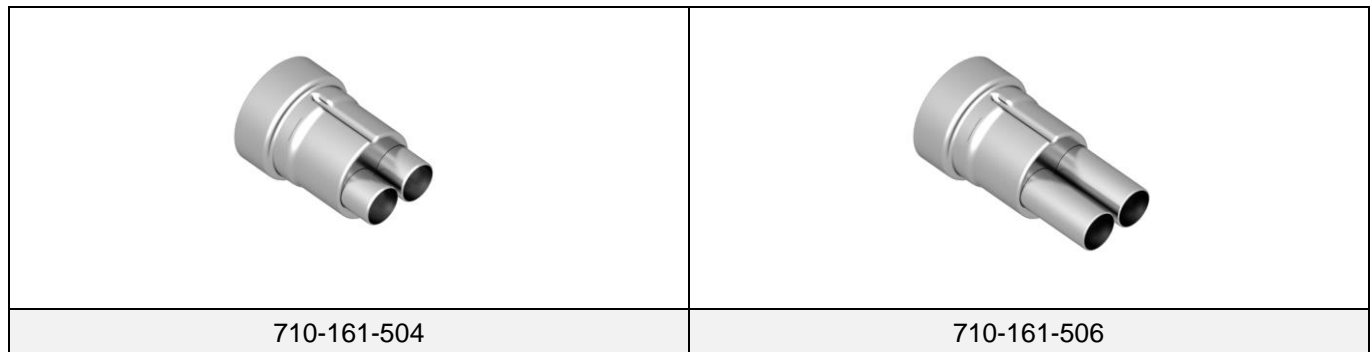

Table 2.16: Overview HPS40-2 2+2 shielding sleeve 4.0 mm² & 6.0 mm² SCC (2.3 Article representation)

Article description	Article number	Drawing number	OEM-specific article
HPS40-2 2+2 shielding sleeve 4.0 mm ² SCC	710-161-504	710-161-...00	-
HPS40-2 2+2 shielding sleeve 6.0 mm ² SCC	710-161-506	710-161-...00	-

Delivery condition: The shielding sleeves are delivered as bulk goods.



2.3.5 HPS40-2 2+2 ferrule crimp 4.0 mm² SCC

Figure 2.5: Representation HPS40-2 2+2 ferrule crimp 4.0 mm² SCC (2.3 Article representation)

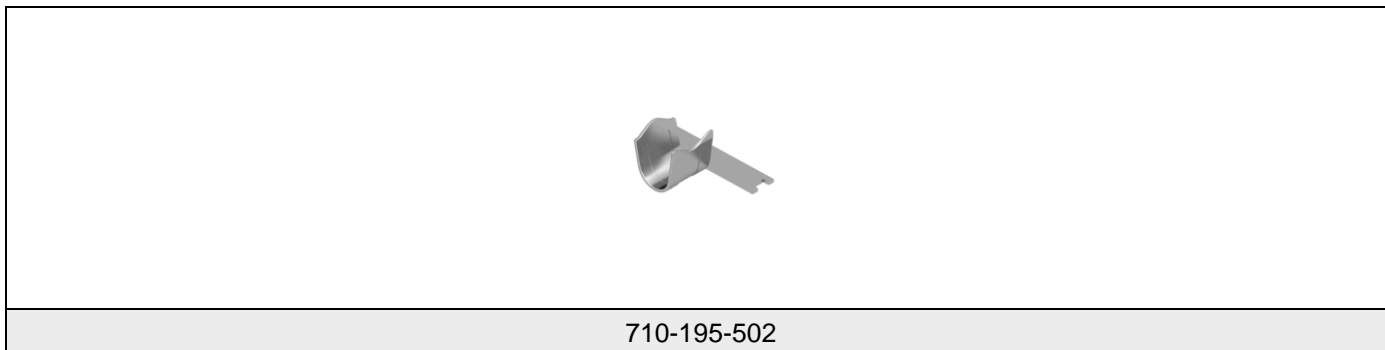

Table 2.17: Overview HPS40-2 2+2 ferrule crimp 4.0 mm² SCC (2.3 Article representation)

Article description	Article number	Drawing number	OEM-specific article
HPS40-2 2+2 ferrule crimp 4.0 mm ² SCC	710-195-502	710-195-...00	-

Delivery condition: The ferrule crimps are delivered on a spool.



2.3.6 HPS40-2 2+2 stress relief 6.0 mm² SCC

Figure 2.6: Representation HPS40-2 2+2 stress relief 6.0 mm² SCC (2.3 Article representation)

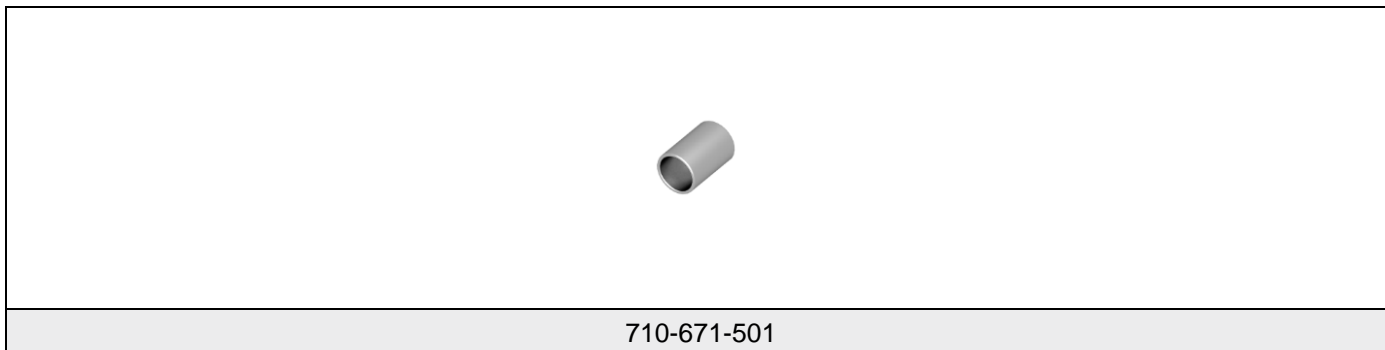

Table 2.18: Overview HPS40-2 2+2 stress relief 6.0 mm² SCC (2.3 Article representation)

Article description	Article number	Drawing number	OEM-specific article
HPS40-2 2+2 stress relief 6.0 mm ² SCC	710-671-501	710-671-...00	-

Delivery condition: The stress reliefs are delivered as bulk goods.

2.3.7 HPS40-2 2+2 X-Ring 6.0 mm² SCC

Figure 2.7: Representation HPS40-2 2+2 X-Ring 6.0 mm² SCC (2.3 Article representation)

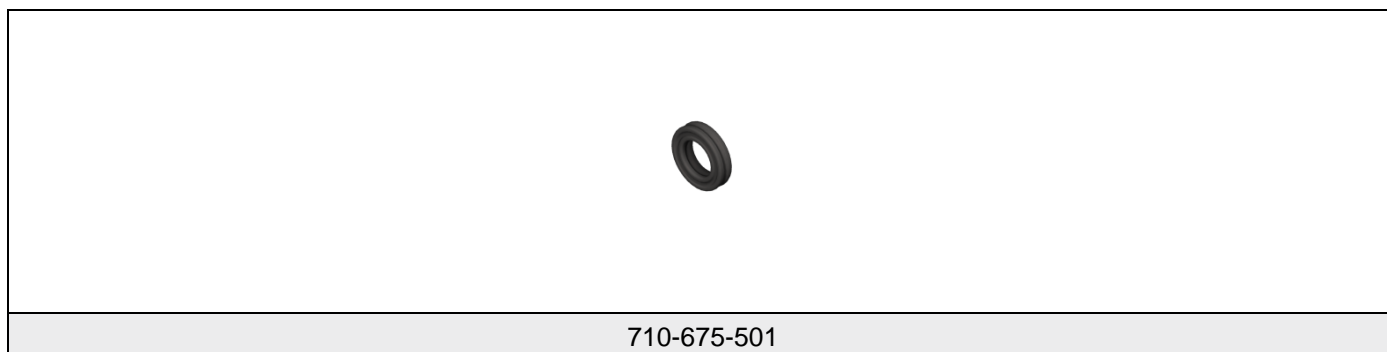

Table 2.19: Overview HPS40-2 2+2 X-Ring 6.0 mm² SCC (2.3 Article representation)

Article description	Article number	Drawing number	OEM-specific article
HPS40-2 2+2 X-Ring 6.0 mm ² SCC	710-675-501	710-675-...00	-

Delivery condition: The X-Rings are delivered as bulk goods.



2.3.8 HPS40-2 2+2 cable seal 4.0 mm² & 6.0 mm² SCC

Figure 2.8: Representation HPS40-2 2+2 cable seal 4.0 mm² & 6.0 mm² SCC (2.3 Article representation)



	
709-972-502	709-972-504

Table 2.20: Overview HPS40-2 2+2 cable seal 4.0 mm² & 6.0 mm² SCC (2.3 Article representation)

Article description	Article number	Drawing number	OEM-specific article
HPS40-2 2+2 cable seal 4.0 mm ² SCC	709-972-502	709-972-...00	-
HPS40-2 2+2 cable seal 6.0 mm ² SCC	709-972-504	709-972-...00	-

Delivery condition: The cable seals are delivered as bulk goods.



2.3.9 HPS40-2 2+2 cover cap 4.0 mm² & 6.0 mm² SCC non-polarized

Figure 2.9: Representation HPS40-2 2+2 cover cap 4.0 mm² & 6.0 mm² SCC non-polarized (2.3 Article representation)



	
706-822-503	706-822-505

Table 2.21: Overview HPS40-2 2+2 cover cap 4.0 mm² & 6.0 mm² SCC non-polarized (2.3 Article representation)

Article description	Article number	Drawing number	OEM-specific article
HPS40-2 2+2 cover cap 4.0 mm ² SCC (non-polarized)	706-822-503	706-822-...00	-
HPS40-2 2+2 cover cap 6.0 mm ² SCC (non-polarized)	706-822-505	706-822-...00	-

Delivery condition: The cover caps are delivered as bulk goods.

2.3.10 HPS40-2 2+2 cover cap 4.0 mm² & 6.0 mm² SCC polarized

Figure 2.10: Representation HPS40-2 2+2 cover cap 4.0 mm² & 6.0 mm² SCC polarized (2.3 Article representation)



	
706-430-504	706-430-505

Table 2.22: Overview HPS40-2 2+2 cover cap 4.0 mm² & 6.0 mm² SCC polarized (2.3 Article representation)

Article description	Article number	Drawing number	OEM-specific article
HPS40-2 2+2 cover cap 4.0 mm ² SCC (polarized)	706-430-504	706-430-...00	-
HPS40-2 2+2 cover cap 6.0 mm ² SCC (polarized)	706-430-505	706-430-...00	-

Delivery condition: The cover caps are delivered as bulk good.



2.3.11 HCT4 female terminal

Figure 2.11: Representation HCT4 female terminal (2.3 Article representation)

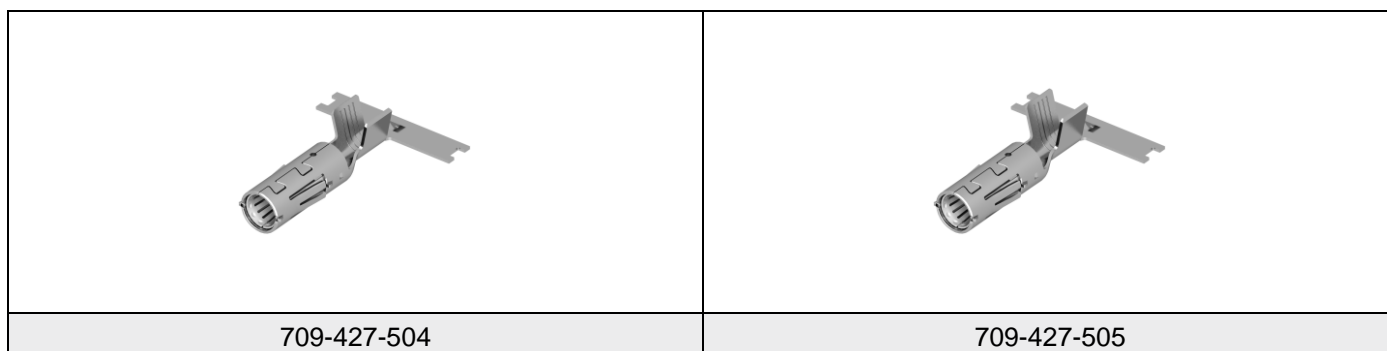

Table 2.23: Overview HCT4 female terminal (2.3 Article representation)

Article description	Article number	Drawing number	OEM-specific article
HCT4 female terminal 4.0 mm ²	709-427-504	709-427-...00	-
HCT4 female terminal 6.0 mm ²	709-427-505	709-427-...00	-

Delivery condition: The female terminals are delivered on a spool.



2.3.12 HPS40-2 2+2 coding clip (optional part)

Figure 2.12: Representation HPS40-2 2+2 coding clip, optional part (2.3 Article representation)



				
706-505-501	706-505-502	706-505-503	706-505-504	706-505-507

Table 2.24: Overview HPS40-2 2+2 coding clip, optional part (2.3 Article representation)

Article description	Article number	Drawing number	OEM-specific article
HPS40-2 2+2 coding clip cod. A	706-505-501	706-505-...00	-
HPS40-2 2+2 coding clip cod. B	706-505-502	706-505-...00	-
HPS40-2 2+2 coding clip cod. C	706-505-503	706-505-...00	-
HPS40-2 2+2 coding clip cod. D	706-505-504	706-505-...00	-
HPS40-2 2+2 coding clip cod. Z	706-505-507	706-505-...00	-

Delivery condition: The coding clips are delivered as bulk goods.

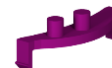
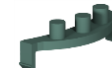

2.3.13 HPS40-2 2+2 90° angled cap (optional part)

Figure 2.13: Representation HPS40-2 2+2 90° angled cap, optional part (2.3 Article representation)



Table 2.25: Overview HPS40-2 2+2 90° angled cap, optional part (2.3 Article representation)

Article description	Article number	Drawing number	OEM-specific article
HPS40-2 2+2 90° angled cap	706-506-503	706-506-...00	-

Delivery condition: The 90° angled caps are delivered as bulk goods.

If the 90° angled cap is used, the cover cap is not needed.



2.3.14 HPS40-2 2+2 protection cap (optional part)

Figure 2.14: Representation HPS40-2 2+2 protection cap, optional part (2.3 Article representation)

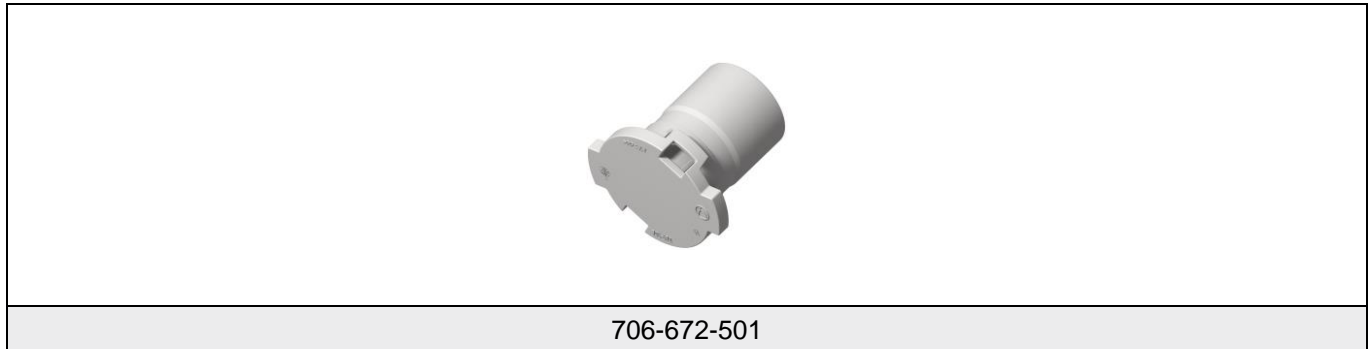

Table 2.26: Overview HPS40-2 2+2 protection cap, optional part (2.3 Article representation)

Article description	Article number	Drawing number	OEM-specific article
HPS40-2 2+2 protection cap	706-672-501	706-672-...00	-

Delivery condition: The protection caps are delivered as bulk goods.

2.3.15 HPS40-2 2+2 In-Line CPA cover (optional part for HPS In-Line)

Figure 2.15: Representation HPS40-2 2+2 In-Line CPA cover, optional part for HPS In-Line (2.3 Article representation)

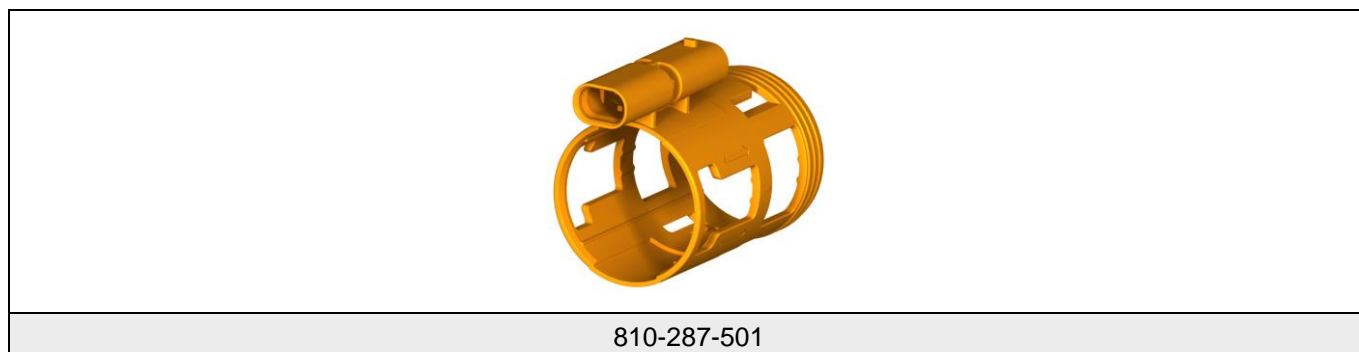

Table 2.27: Overview HPS40-2 2+2 In-Line CPA cover, optional part for HPS In-Line (2.3 Article representation)

Article description	Article number	Drawing number	OEM-specific article
HPS40-2 2+2 In-Line CPA cover	810-287-501	810-287-...00	-

Delivery condition: The In-Line CPA covers are delivered as bulk goods.

The In-Line CPA cover is only used in conjunction with the HPS In-Line female connector. The structure of the HPS In-Line female connector is identical to the HPS40-2 2+2 female connector, except for the additional In-Line CPA cover.

3 Processing steps 4.0 mm² SCC

In this chapter, the necessary process steps for assembling the HPS40-2 2+2 female connector 4.0 mm² SCC are described. The example images depict the contact carrier with coding A, along with all the necessary components for a 4.0 mm² cable.

3.1 Cutting the cable

In this process step, the cable is cut to the required length. An additional length of cable is needed for the assembly of the connector, and this is specified in “**Table 3.1**”.

Figure 3.1: Representation 4.0 mm² SCC cable example (3.1 Cutting the cable)

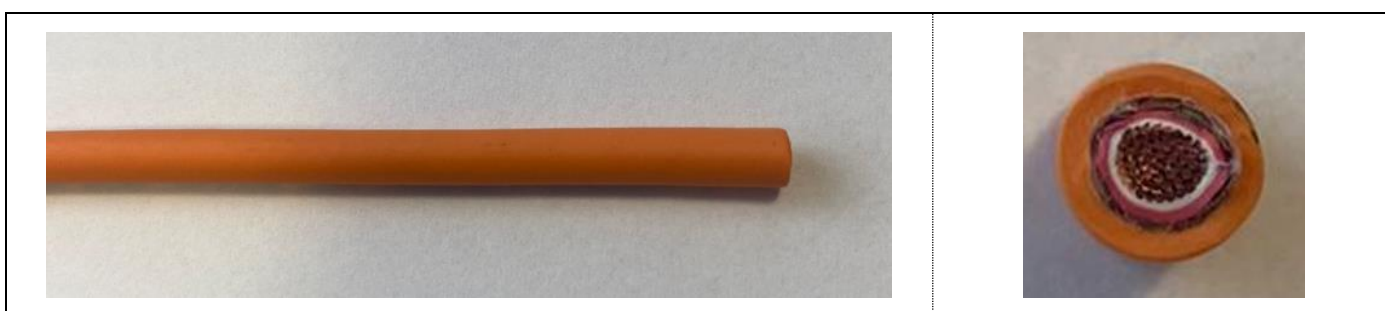

Figure 3.2: Representation 4.0 mm² SCC dimension X0 and dimension D0 (3.1 Cutting the cable)

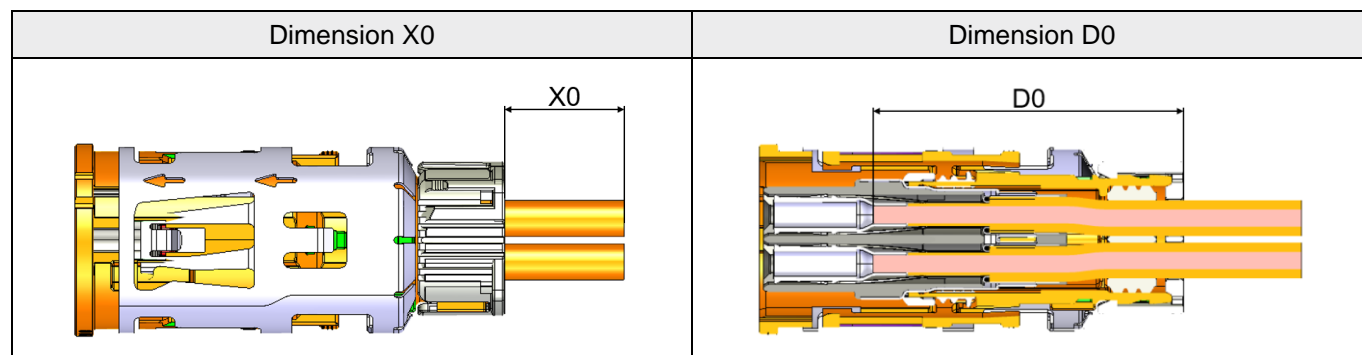

Table 3.1: Overview 4.0mm² SCC dimension D0 (3.1 Cutting the cable)

Cable cross section	Dimension D0
4.0 mm ²	50.0 mm

The dimension X0 exemplarily represents the cable length of the cable assembly and varies depending on the overall length of the cable assembly. Dimension D0 must be added to dimension X0 because the length of dimension D0 is needed for the assembly of the connector.

In the case of using equipment with zero trim for following processes, it should be noted that the dimension for the zero trim must be added to the dimension D0. The exact length of the zero trim varies, as each piece of equipment performing a zero trim may cut different lengths.

3.2 Assemble individual components

During this process step, the initial required individual components are assembled in the order of the cover cap (1), cable seal (2), locking sleeve (3), and shielding sleeve (4) according to **"Figure 3.3"**. For the cable seal (2), locking sleeve (3), and shielding sleeve (4), no specific orientation is required, they can be assembled in any orientation.

Figure 3.3: Representation 4.0 mm² SCC assemble individual components (3.2 Assemble individual components)

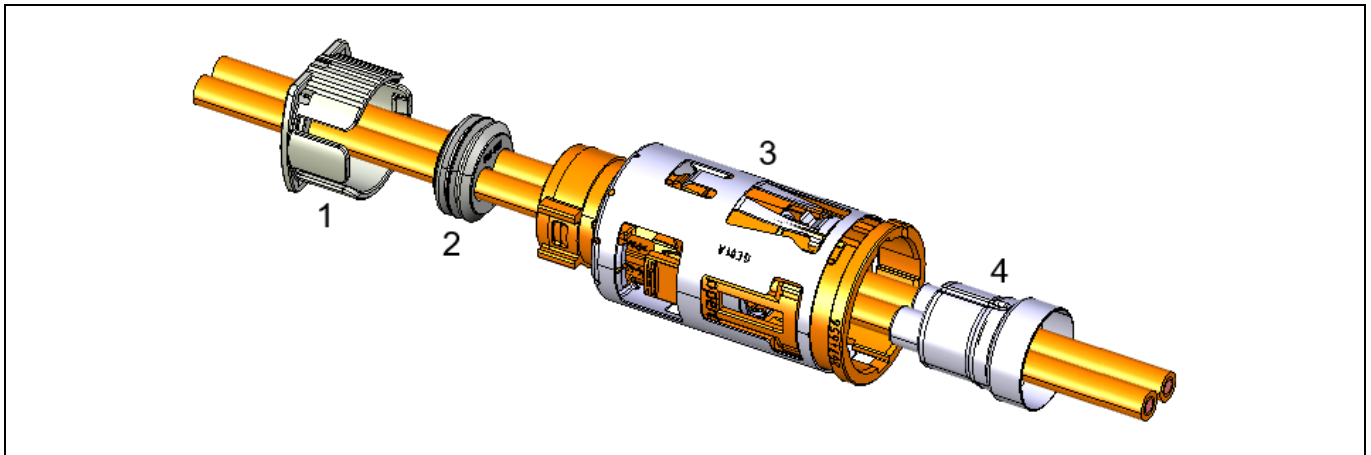

The cable seal may be slightly expanded during assembly.

The locking sleeve (3) and the shielding sleeve (4) can also be assembled onto the cable after the crimping process of the HCT4 female terminals, which is described in **Chapter "3.6 Crimp the HCT4 female terminal"**.

If the HPS40-2 2+2 cover cap 4.0 mm² SCC non-polarized (706-822-503) according to **"Figure 2.9"** is used, no specific orientation is required, it can be assembled in any orientation.

If the HPS40-2 2+2 cover cap 4.0 mm² SCC polarized (706-430-504) according to **"Figure 2.10"** is used, pay attention to the pin assignment as shown in **"Figure 3.4"**, as it cannot be rotated afterwards.

Figure 3.4: Representation 4.0 mm² SCC pin assignment HPS40-2 2+2 cover cap 4.0 mm² SCC polarized (3.2 Assemble individual components)

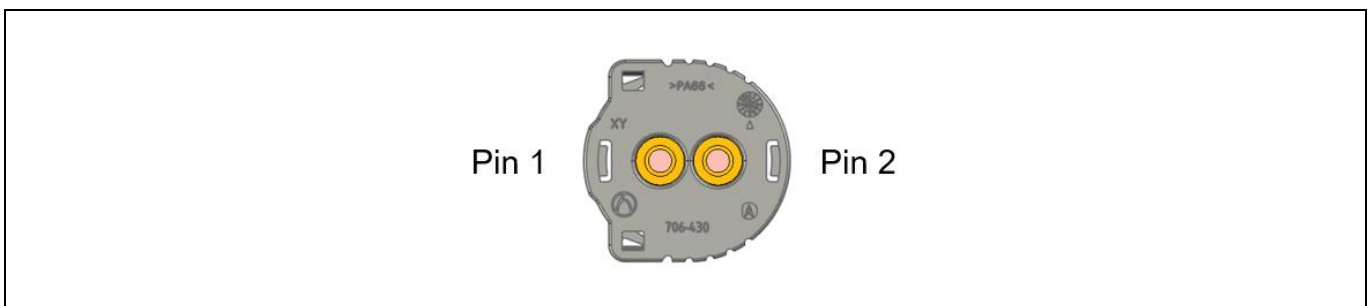

3.3 Strip off the cable

In this process step, the cable is stripped to the required length specified in “**Table 3.2**”.

Figure 3.5: Representation 4.0 mm² SCC stripped off cable example (3.3 Strip off the cable)



Figure 3.6: Representation 4.0 mm² SCC dimension D1 (3.3 Strip off the cable)

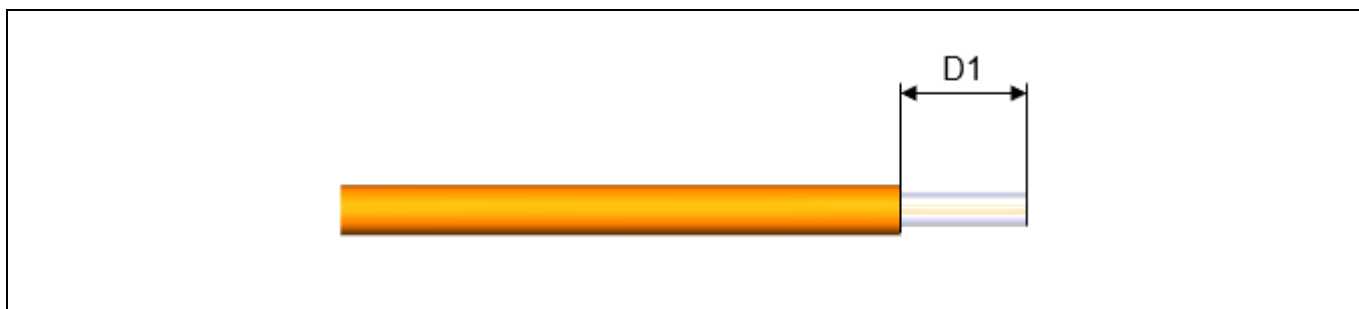

Table 3.2: Overview 4.0mm² SCC dimension D1 (3.3 Strip off the cable)

Cable cross section	Dimension D1
4,0 mm ²	18,0 ± 1,0 mm

3.4 Remove shielding foil (if present), trim shielding braid, and crimp the ferrule crimp

In this process step, the shielding foil is removed (if present), the shielding braid is trimmed, and the ferrule crimp is crimped onto the cable, as shown in **“Figure 3.7”**. The processor can determine the order of these processes themselves.

Figure 3.7: Representation 4.0 mm² SCC remove shielding foil (if present), trim shielding braid, and crimp the ferrule crimp (3.4 Remove shielding foil (if present), trim shielding braid, and crimp the ferrule crimp)



The ferrule crimp must be crimped parallel to the cable, and in alignment with the front end of the cable, as shown in **“Figure 3.8”**. The required dimension is specified in **“Table 3.3”**.

Figure 3.8: Representation 4.0 mm² SCC dimension D2 (3.4 Remove shielding foil (if present), trim shielding braid, and crimp the ferrule crimp)

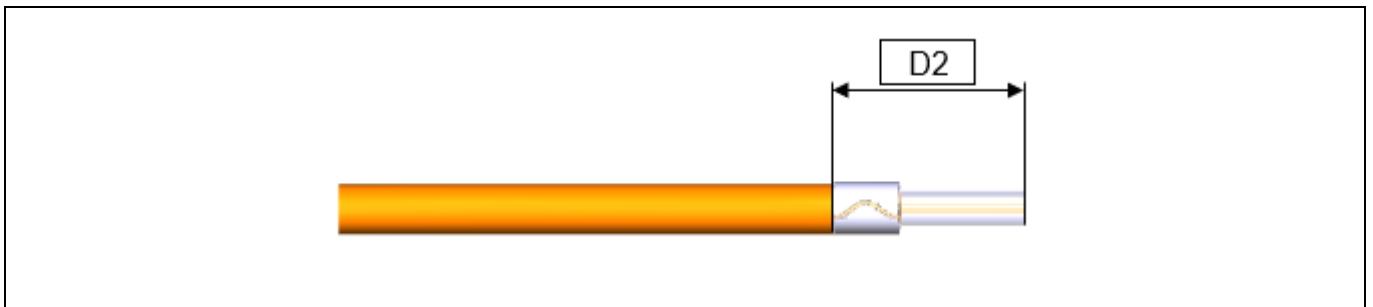

Table 3.3: Overview 4.0 mm² SCC dimension D2 (3.4 Remove shielding foil (if present), trim shielding braid, and crimp the ferrule crimp)

Cable cross section	Dimension D2
4.0 mm ²	max. 25.5 mm



If necessary, the cable can be stripped after crimping the jacket crimp. In this case, a maximum overlap of the inner jacket of 2.0 mm, as shown in “**Figure 3.9**”, must be ensured.

Figure 3.9: Representation 4.0 mm² SCC maximum overlap of 2.0 mm (3.4 Remove shielding foil (if present), trim shielding braid, and crimp the ferrule crimp)

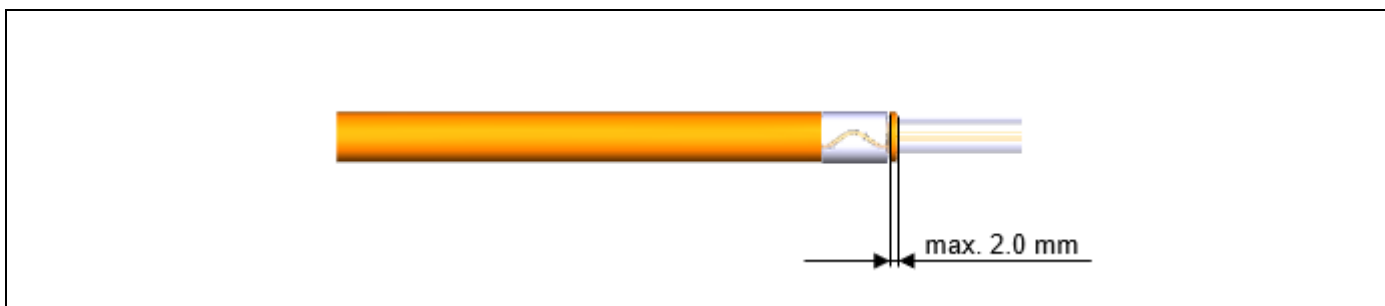

The dimension DØ0 must be measured in the crimping direction, as shown in “**Figure 3.10**”. The required dimension is specified in “**Table 3.4**”.

Figure 3.10: Representation 4.0 mm² SCC dimension Ø X (3.4 Remove shielding foil (if present), trim shielding braid, and crimp the ferrule crimp)

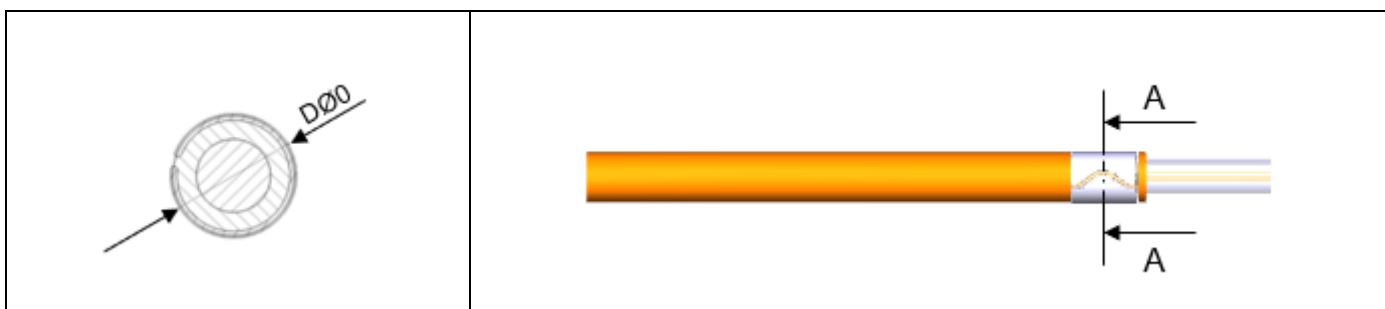
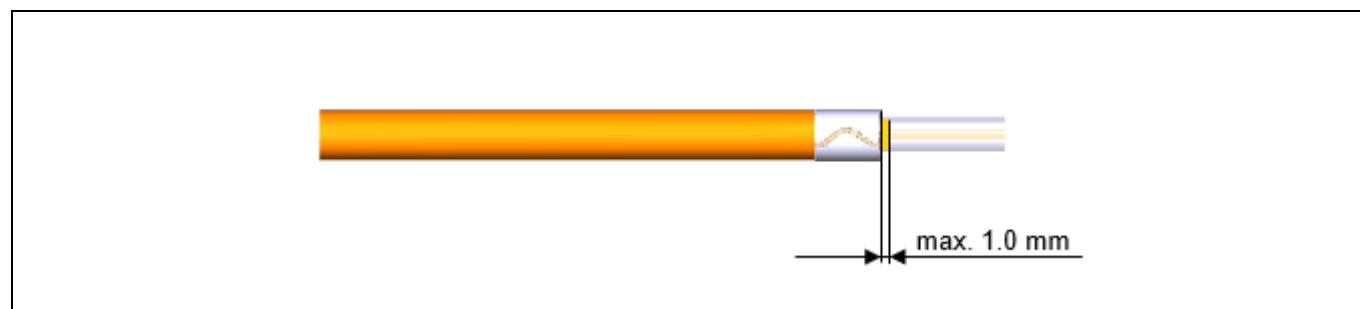

Table 3.4: Overview 4.0 mm² SCC dimension DØ0 (3.4 Remove shielding foil (if present), trim shielding braid, and crimp the ferrule crimp)

Cable cross section	Dimension DØ0
4.0 mm ²	6.1 ± 0.1 mm

If a shielding foil is present, a circumferential protrusion in the area of the shielding braid of a maximum of 1.0 mm is permissible, as shown in “**Figure 3.11**”. Non-circumferential individual tears ≤ 3.0 mm are also permissible.

Figure 3.11: Representation 4.0 mm² SCC overhang shielding foil (3.4 Remove shielding foil (if present), trim shielding braid, and crimp the ferrule crimp)





Depending on the processing method of the processor, the dimension D3 as shown in “**Figure 3.12**” can vary. The dimension must be chosen so that the end or the cutting edge of the shielding strands are located under the tape, which is described in **Chapter “3.5 Fold over the shielding braid and secure the shielding braid”** and “**Figure 3.15**”.

Figure 3.12: Representation 4.0 mm² SCC dimension D3 (3.4 Remove shielding foil (if present), trim shielding braid, and crimp the ferrule crimp)

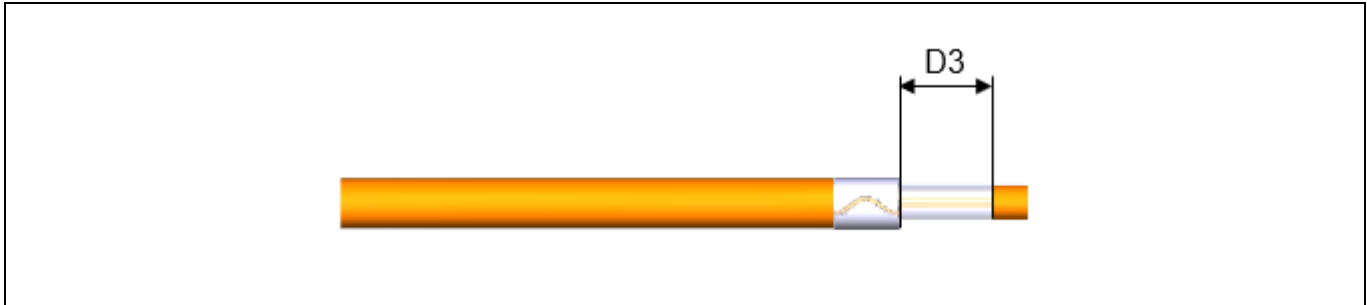

After trimming the shielding braid, no cable strands or remnants of the shielding braid are allowed on the cable. These residues must be removed by suitable methods such as blowing or suction.

3.5 Fold over the shielding braid and secure the shielding braid

In this process step, the shielding braid is folded over and fixed on the cable with tape, as shown in **“Figure 3.13”**.

Figure 3.13: Representation 4.0 mm² SCC fold over the shielding braid and secure the shielding braid (3.5 Fold over the shielding braid and secure the shielding braid)



The shielding braid must be completely and tightly folded backwards over the ferrule crimp. No strands of the shielding braid may be facing towards the two inner conductors. The shielding braid should be preserved as shown in **“Figure 3.14”**. Targeted unbraiding of the shielding braid is not allowed, but process-related unbraiding may occur when folding over the shielding braid.

Figure 3.14: Representation 4.0 mm² SCC preserved shielding braid (3.5 Fold over the shielding braid and secure the shielding braid)



Subsequently, the shielding braid must be fixed behind the ferrule crimp with a suitable tool, for example, with a fixing tape, as shown in **“Figure 3.15”**. The fixing tape must fix the shielding braid until the shielding sleeve is crimped.

Figure 3.15: Representation 4.0 mm² SCC fixing the shielding braid (3.5 Fold over the shielding braid and secure the shielding braid)



The maximum allowed width of the fixing tape is 5.0 mm, as shown in “**Figure 3.16**”.

Figure 3.16: Representation 4.0 mm² SCC 5.0 mm fixing tape (3.5 Fold over the shielding braid and secure the shielding braid)



The fixing tape must be positioned behind the ferrule crimp and must not be on the ferrule crimp, as shown in “**Figure 3.17**”.

Figure 3.17: Representation 4.0 mm² SCC position fixing tape related to the ferrule crimp (3.5 Fold over the shielding braid and secure the shielding braid)



There should be no shielding braid protruding from the back of the fixing tape, as shown in “**Figure 3.18**”.

Figure 3.18: Representation 4.0 mm² SCC position protruded shielding braid (3.5 Fold over the shielding braid and secure the shielding braid)



The maximum end position of the fixing tape is shown by dimension D4 in “**Figure 3.19**”. The reference edges of dimension D4 are the front surface of the cut cable and the end of the fixing tape. The required dimension is specified in “**Table 3.5**”.

Figure 3.19: Representation 4.0 mm² SCC dimension D4 (3.5 Fold over the shielding braid and secure the shielding braid)

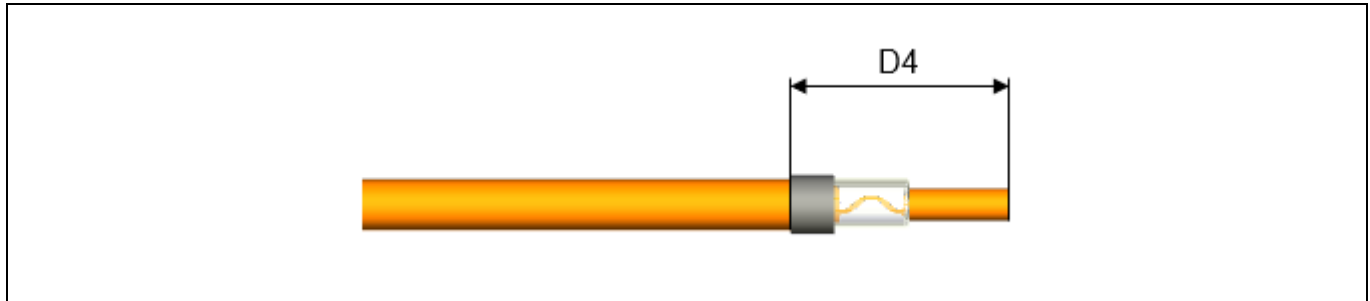

Table 3.5: Overview 4.0 mm² SCC dimension D4 (3.5 Fold over the shielding braid and secure the shielding braid)

Cable cross section	Dimension D4
4.0 mm ²	max. 35.0 mm

In this specification, the PET fabric adhesive tape 837X (838X) with a width of 5.0 mm from the company Coroplast was used, as shown in “**Figure 3.20**”. If necessary, another suitable tool for fixing the shielding braid can be used, provided it does not exceed a maximum outer diameter of Ø 6.75 mm, and the shielding sleeve can be easily mounted. The fixing tool must have a temperature resistance of at least 150°C.

Figure 3.20: Representation 4.0 mm² SCC coroplast 837X/838X 5.0 mm tape (3.5 Fold over the shielding braid and secure the shielding braid)



Single strands of the shielding braid that are not held by the fixing tape and, if necessary, protrude outward or forward must be removed before further processing.

3.6 Crimp the HCT4 female terminal

In this process step, the HCT4 female terminal is crimped onto the cable as shown in “**Figure 3.21**”. The crimp data can be found in the process specification HCT4 female terminal EVS-100068. If the contact carriers HPS40-2 2+2 female contact carrier 4.0 mm² & 6.0 mm² SCC which are listed in “**Figure 2.3**” are used, the stripping length mentioned in the EVS-100068 can be extended by a maximum of 2.0 mm.

Figure 3.21: Representation 4.0 mm² SCC crimped HCT4 female terminal (3.6 Crimp the HCT4 female terminal)



The HCT4 female terminal must be crimped parallel to the cable.

The dimensions D5, D6 and D7, as shown in “**Figure 3.22**”, result from the dimensions D1, D4, and EVS-100068. A mark on the insulation of the individual cable or on the outer sheath caused by fixing the cable during the crimping process is allowed. However, it must be ensured that the insulation is not damaged (torn, penetrated, etc.), as this would lead to an insulation failure. The required dimensions are specified in “**Table 3.6**”.

At the area of the cable seal, it is not allowed to deform or damage the outer sheath, as this can have a negative impact on the sealing function. If agreed upon by the OEM, either D2 or D5 must be proven, as they correlate.

Figure 3.22: Representation 4.0 mm² SCC dimension D5, D6 and D7 (3.6 Crimp the HCT4 female terminal)

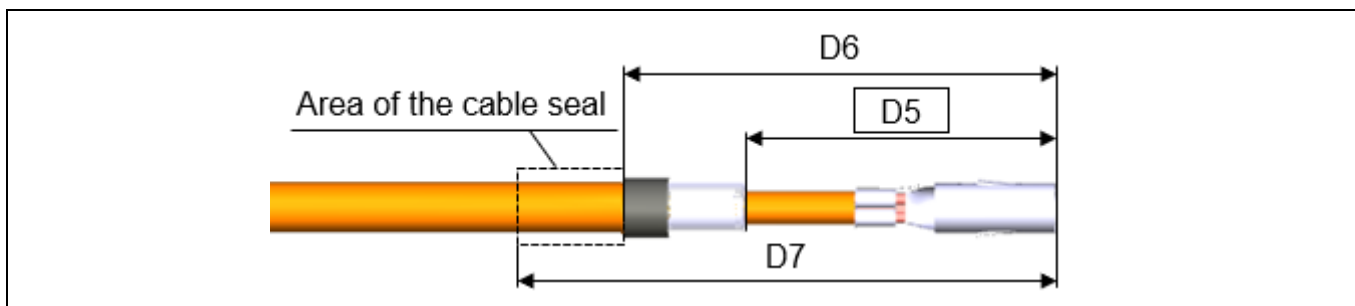

Table 3.6: Overview 4.0 mm² SCC dimension D5, D6 and D7 (3.6 Crimp the HCT4 female terminal)

Cable cross section	Dimension D5	Dimension D6	Dimension D7
4.0 mm ²	34.75 ± 0.75 mm	max. 51.0 mm	max. 67.0 mm



To measure the dimension D5, the folded-over shielding braid serves as the reference edge, as shown in **“Figure 3.23”**.

Figure 3.23: Representation 4.0 mm² SCC dimension D5 reference edge (3.6 Crimp the HCT4 female terminal)

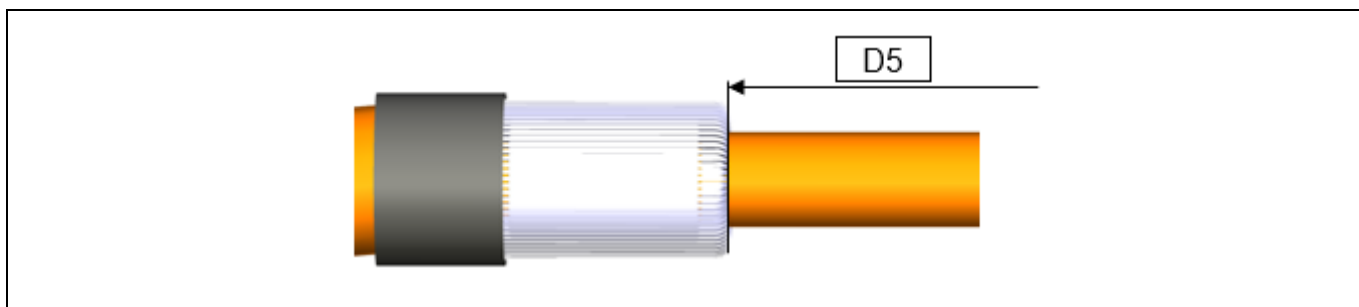



3.7 Inserting HCT4 female terminals into the contact carrier

In this process step, the cables with the crimped HCT4 female terminals are assembled into the contact carrier as shown in “**Figure 3.24**”. If two cables with the same color are used, the pinning must be confirmed by electrical testing.

While populating the HCT4 female terminals into the contact carrier, the latching lance of the HCT4 female terminals is deflected. Once the end position is reached, the latching lance audibly engages, and the HCT4 female terminals are primary locked.

Figure 3.24: Representation 4.0 mm² SCC inserting into the contact carrier (3.7 Inserting HCT4 female terminals into contact carrier)

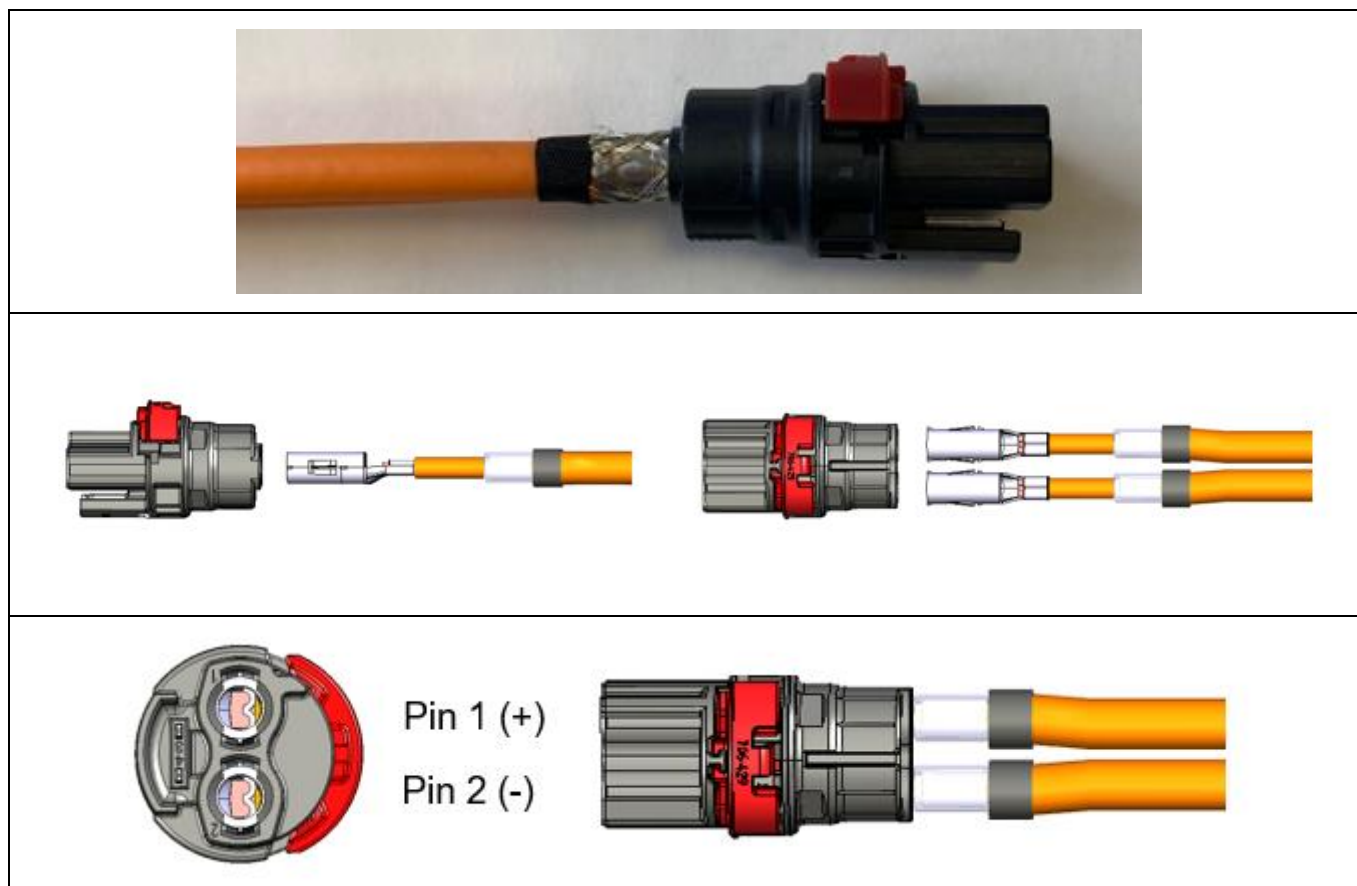



The allowed angular deviation when inserting the HCT4 female terminals, as shown in “**Figure 3.25**”, results from the geometry of the lead-in chamfers on the contact carrier and the maximum permissible assembly force of the cables with the HCT4 female terminals into the contact carrier, which are listed in “**Table 3.7**”.

Figure 3.25: Representation 4.0 mm² SCC lead-in chamfers contact carrier (3.7 Inserting HCT4 female terminals into contact carrier)

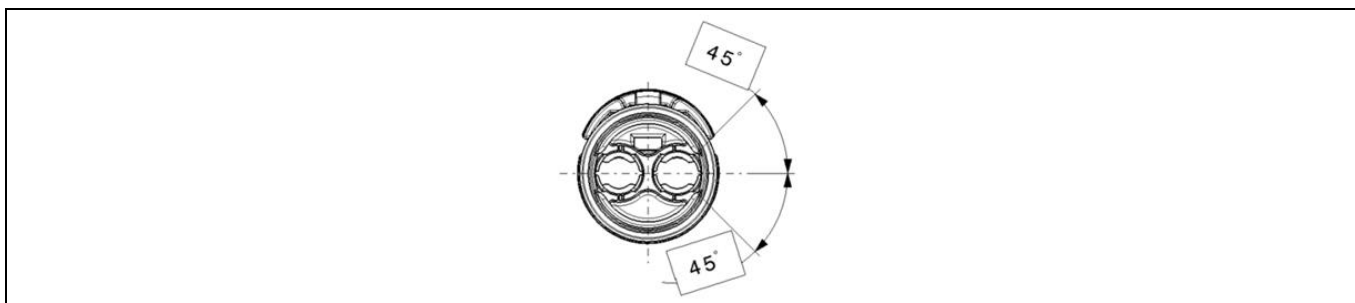

In order to ensure that the end position of the HCT4 female terminals in the contact carrier is achieved, either the mounting force or the attainment of the end position must be proven. This is only relevant if the mounting of the HCT4 female terminals into the contact carrier is not performed fully automatically. In fully automatic assembly solutions, these functions can be integrated into the machine. The maximum permissible assembly force is shown in “**Table 3.7**”.

Table 3.7: Overview 4.0 mm² SCC maximum permissible assembly force (3.7 Inserting HCT4 female terminals into contact carrier)

Cable manufacturer	Cable type	According Chapter 1.6	Cable cross section	Maximum force
Coficab	FHLR91XCB91X T4 PSA	C	4.0 mm ²	30.0 N
Coroflex	FHLR2GCB2G 4.0 mm ² / 0.21 T180	D	4.0 mm ²	30.0 N
Gebauer & Griller	FHLR2GCB2G 1x4.0/T180 OR	O	4.0 mm ²	30.0 N
Huber & Suhner	FHLR91XC13X-1x4 T150	B	4.0 mm ²	30.0 N
Leoni	FHLR2GCB2G 4,0/0,31/T180	F	4.0 mm ²	30.0 N
Aptiv	FHLR91XC91X-B 4.0mm ² <i>„wait for OEM approval”</i>	Q	4.0 mm ²	30.0 N



If the HCT4 female terminals are assembled incorrectly into the contact carrier, this can cause a plastic burr inside the contact carrier chamber and the HCT4 female terminals, as shown in “**Figure 3.26**”. These contact carriers must no longer be used and must be scrapped.

Figure 3.26: Representation 4.0 mm² SCC plastic burr on contact carrier (3.7 Inserting HCT4 female terminals into contact carrier)



The HCT4 female terminals must also be checked for plastic burrs and cleaned before further assembly. If cleaning does not remove all residual plastic, the HCT4 female terminals must also be scrapped.



3.8 Close secondary lock on the contact carrier

In this process step, the secondary lock on the contact carrier is closed, as shown in “**Figure 3.27**”.

Figure 3.27: Representation 4.0 mm² SCC close secondary lock on the contact carrier (3.8 Close secondary lock on the contact carrier)



The secondary lock can only be closed when the HCT4 female terminals are in the end position. A possible visible positional difference of the HCT4 female terminals in the contact carrier chamber to each other may result from the HCT4 female terminal position on the cable and the locking play of the HCT4 female terminal in the contact carrier chamber and is permissible. The pre-locking and locking positions of the secondary lock on the contact carrier are shown in “**Figure 3.28**”. In the pre-locking position of the secondary lock on the contact carrier, the HCT4 female terminals are only primarily locked. In the locking position of the secondary lock on the contact carrier, the HCT4 female terminals are both primarily and secondarily locked.

Figure 3.28: Representation 4.0 mm² SCC pre-locking and locking position secondary lock (3.8 Close secondary lock on the contact carrier)

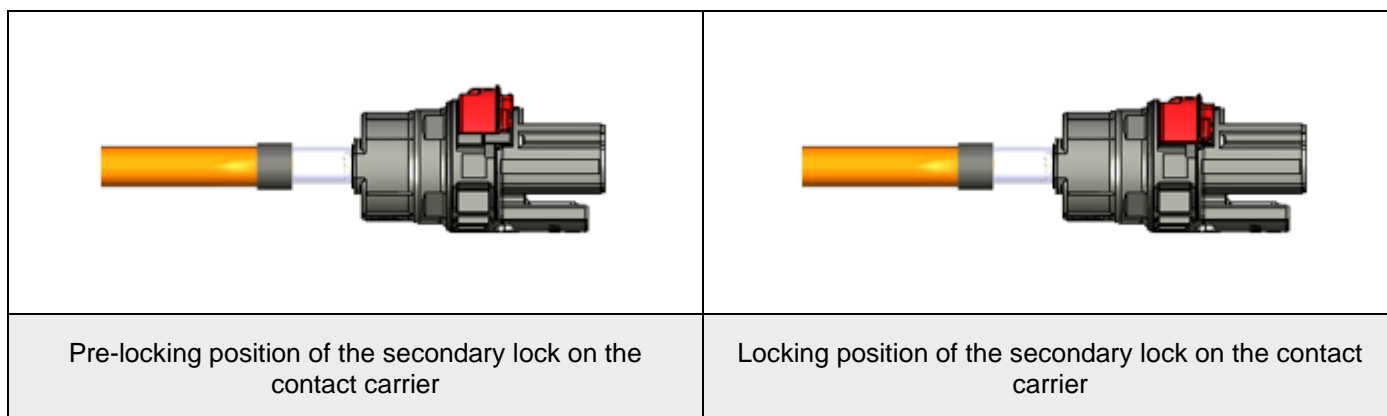

3.9 Slide the shielding sleeve onto the contact carrier

In this process step, the shielding sleeve is slid onto the contact carrier, as shown in “**Figure 3.29**”.

Figure 3.29: Representation 4.0 mm² SCC slide the shielding sleeve onto the contact carrier (3.9 Slide the shielding sleeve onto the contact carrier)



The cables must be secured during this process to prevent the cables and/or the ferrule crimp from being compressed or pushed inside the connector, as this can cause damage to the insulation (“**Figure 3.30**”) and thus lead to dielectric breakdown. Neither the cables nor any other component may be damaged by the clamping process.

Figure 3.30: Representation 4.0 mm² SCC risk of insulation failure (3.9 Slide the shielding sleeve onto the contact carrier)



The shielding sleeve must be slid onto the contact carrier in a polarized manner using the two existing polarization grooves on both the shielding sleeve and the contact carrier, as shown in “**Figure 3.31**”. The shielding sleeve is a symmetrical component and can therefore be mounted in two positions, rotated by 180°. This means that it is not necessary to pay attention to which polarization groove of the shielding sleeve is used with the polarization groove of the contact carrier.

Figure 3.31: Representation 4.0 mm² SCC polarization shielding sleeve and contact carrier (3.9 Slide the shielding sleeve onto the contact carrier)

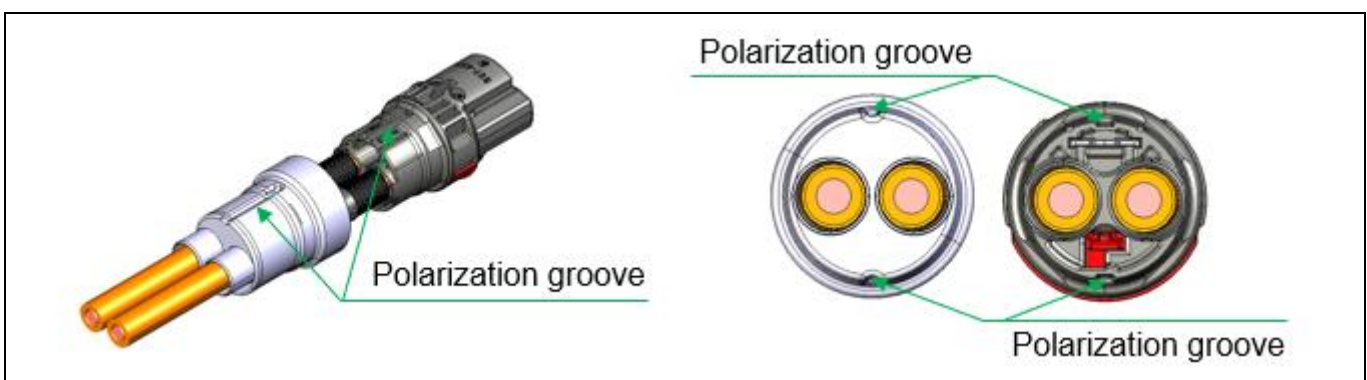

The shielding sleeve must be pushed forward until it abuts against the collar of the contact carrier, as shown in **“Figure 3.32”**.

Figure 3.32: Representation 4.0 mm² SCC end position shielding sleeve on contact carrier (3.9 Slide the shielding sleeve onto the contact carrier)

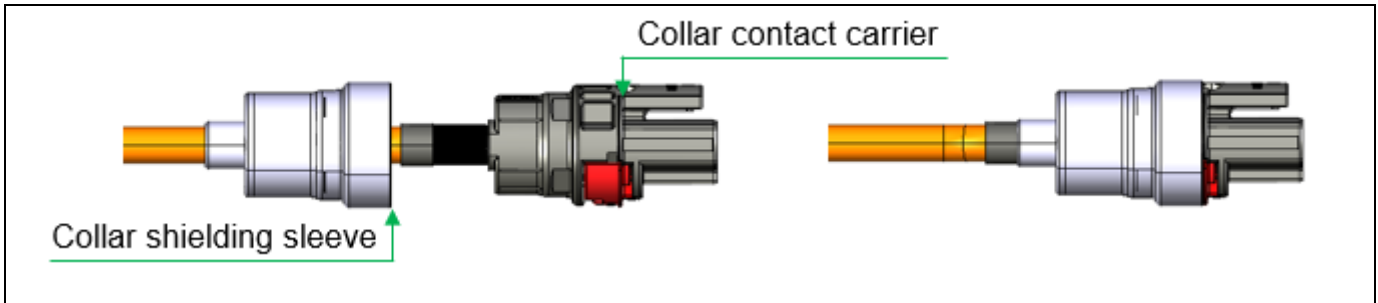

The fixing tape must protrude completely from the shielding sleeve after sliding, as shown in **“Figure 3.33”**.

Figure 3.33: Representation 4.0 mm² SCC protruded fixing tape (3.9 Slide the shielding sleeve onto the contact carrier)



It must be ensured that no individual shielding strands protrude before the shielding sleeve is mounted, as shown in **“Figure 3.34”**. If necessary, protruding individual shielding strands can be removed. This rework must be clarified with the respective OEM.

Figure 3.34: Representation 4.0 mm² SCC protruded individual shielding strands (3.9 Slide the shielding sleeve onto the contact carrier)



3.10 Crimp the shielding sleeve

In this process step, the shielding sleeve is crimped onto the cables and onto the contact carrier, as shown in “**Figure 3.35**”.

Figure 3.35: Representation 4.0 mm² SCC crimp the shielding sleeve (3.10 Crimp the shielding sleeve)



The cable shielding crimping (shielding sleeve, shielding braid, ferrule crimp, and cable) as well as the contact carrier crimping (shielding sleeve and contact carrier) are performed simultaneously, as shown in “**Figure 3.36**”.

Figure 3.36: Representation 4.0 mm² SCC shielding crimping and contact carrier crimping (3.10 Crimp the shielding sleeve)

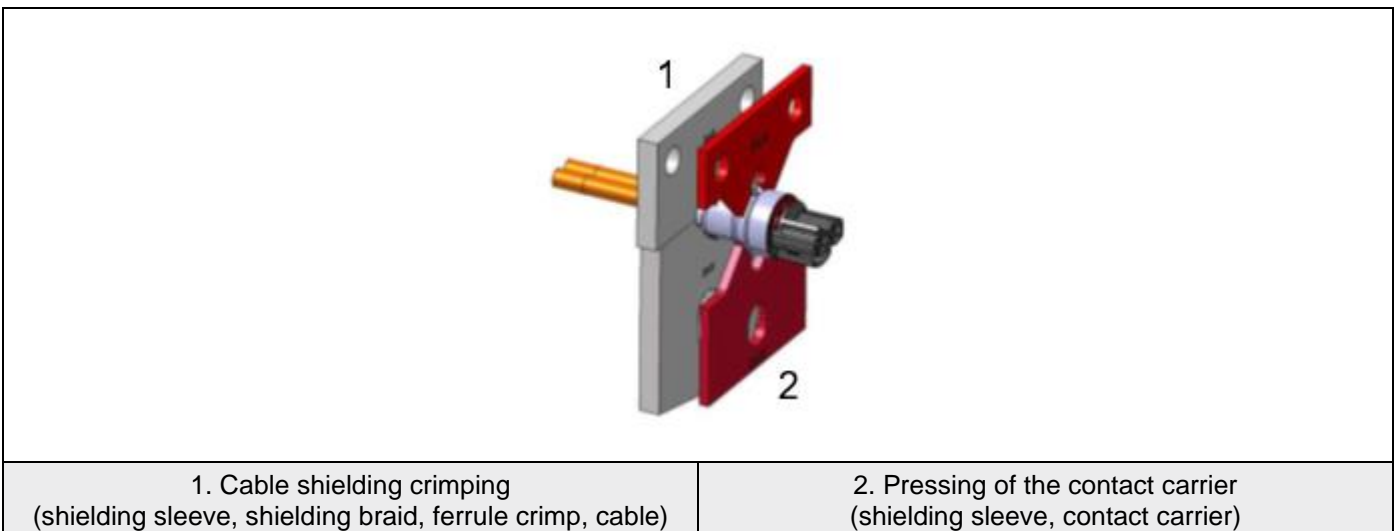



The contact carrier must be oriented correctly to the crimping tool. The dimensions specified in “**Table 3.8**” must be adhered to before and after crimping.

Figure 3.37: Representation 4.0 mm² SCC dimension D8 and D9 (3.10 Crimp the shielding sleeve)

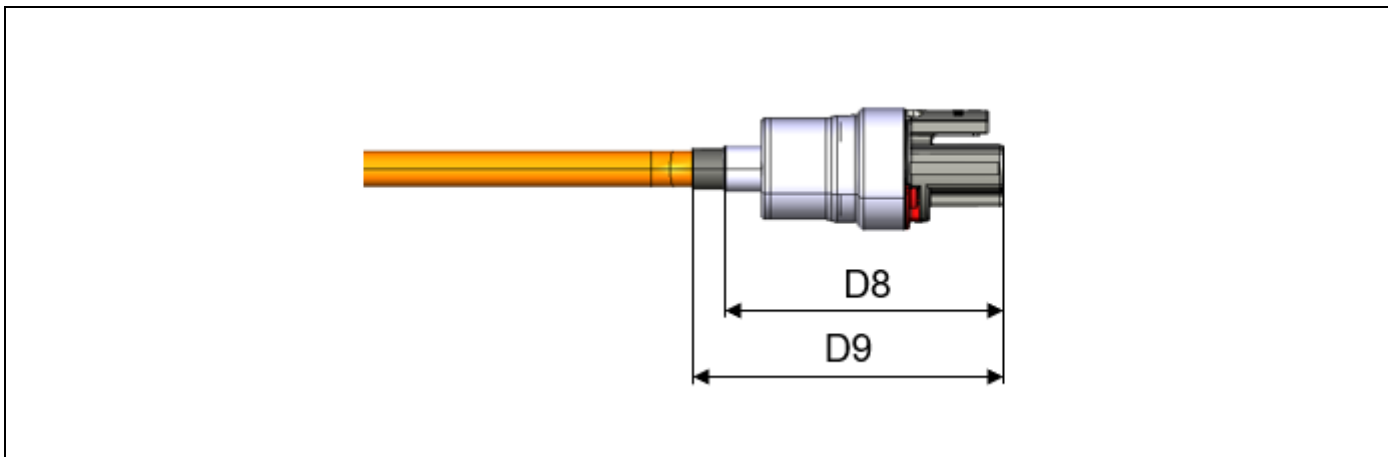

Table 3.8: Overview 4.0 mm² SCC dimension D8 and D9 (3.10 Crimp the shielding sleeve)

Dimension D8	Dimension D9
44.7 ± 0.25 mm	50.0 ± 1.0 mm

The dimensions D8 and D9 result from dimensions D1, D4, and EVS-100068.

3.10.1 Cable shielding crimping using two half-shells

This chapter describes the position of the crimping tool, the geometries of the plunger and anvil, resulting crimp dimensions, and pull-off forces. The position of the plunger and anvil refers to the front face of the contact carrier, as shown in “**Figure 3.38**”. The dimension D10, which is listed in “**Table 3.9**”, indicates the position of the plunger and anvil. Depending on the version of the plunger and anvil, a different dimension must be used, as listed in “**Table 3.9**”. Additionally, depending on the version of the plunger and anvil, if present, the embossing nose on both the plunger and anvil must point towards the shielding sleeve.

Figure 3.38: Representation 4.0 mm² SCC dimension D10 (3.10.1 Cable shielding crimping using two half-shells)

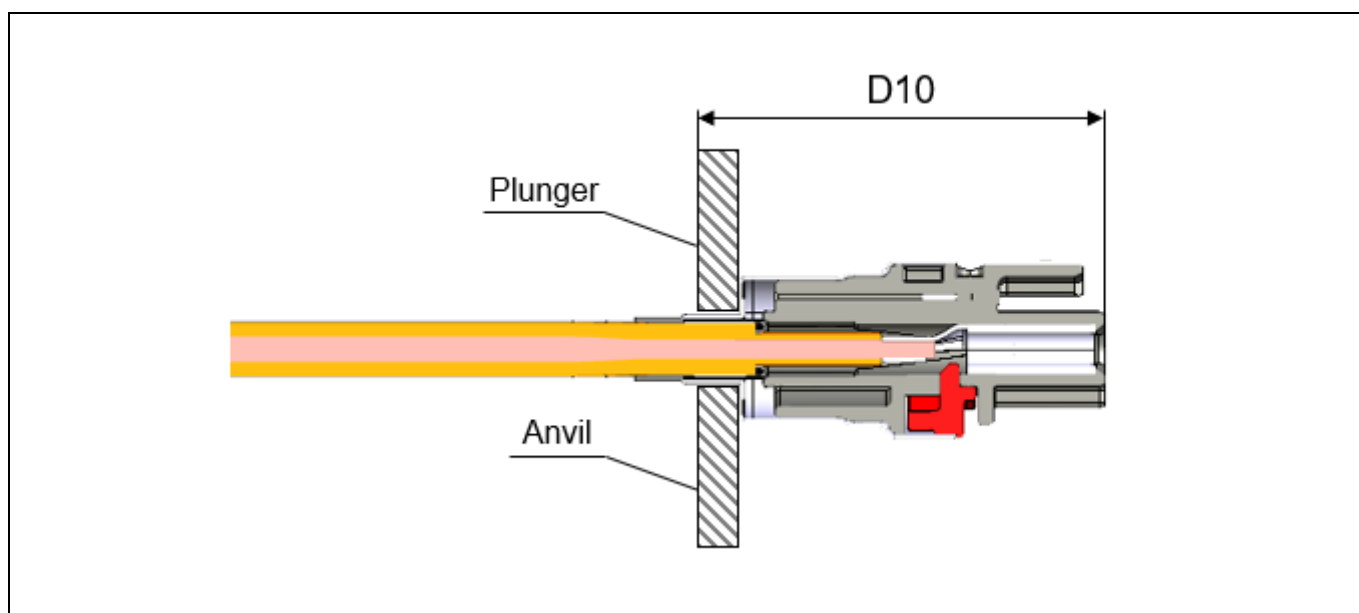

Table 3.9: Overview 4.0 mm² SCC dimension D10 (3.10.1 Cable shielding crimping using two half-shells)

Dimension D10 (Version A)	Dimension D10 (Version B)
44.15 ± 0.1 mm	52.5 ± 0.1 mm



Due to the variety of validated cables, which may have different dimensions or properties, several variants of plunger and anvil combinations are available, as listed in “Figure 3.39” and “Figure 3.40”. In “Table 3.10” and “Table 3.11”, the cables corresponding to the different plunger and anvil versions are shown.

Figure 3.39: Representation 4.0 mm² SCC plunger and anvil Version A (3.10.1 Cable shielding crimping using two half-shells)

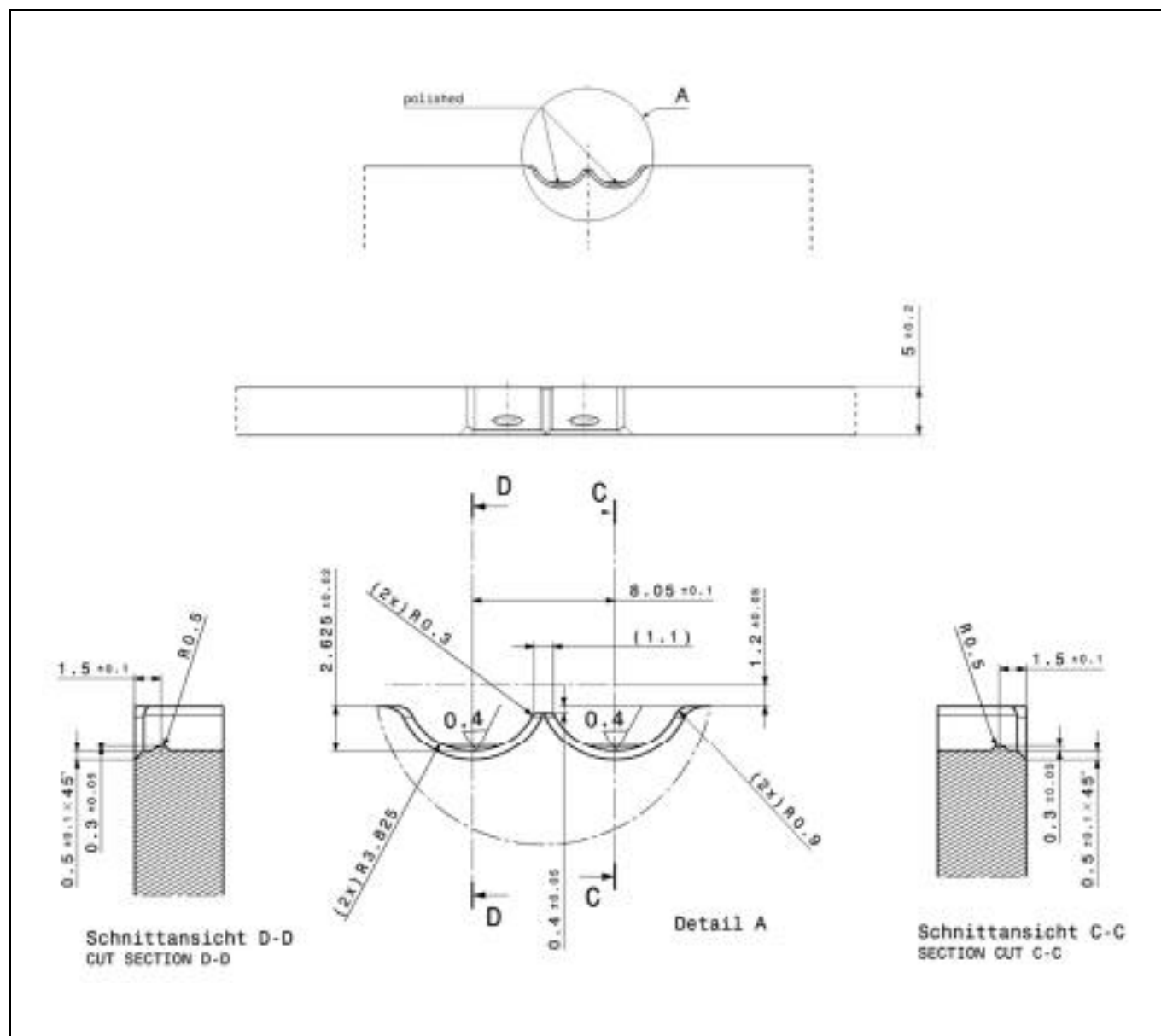

Description	Version	Material
Plunger and anvil	A	1.2721 vacuum hardened 58hrc

Figure 3.40: Representation 4.0 mm² SCC plunger and anvil Version B (3.10.1 Cable shielding crimping using two half-shells)

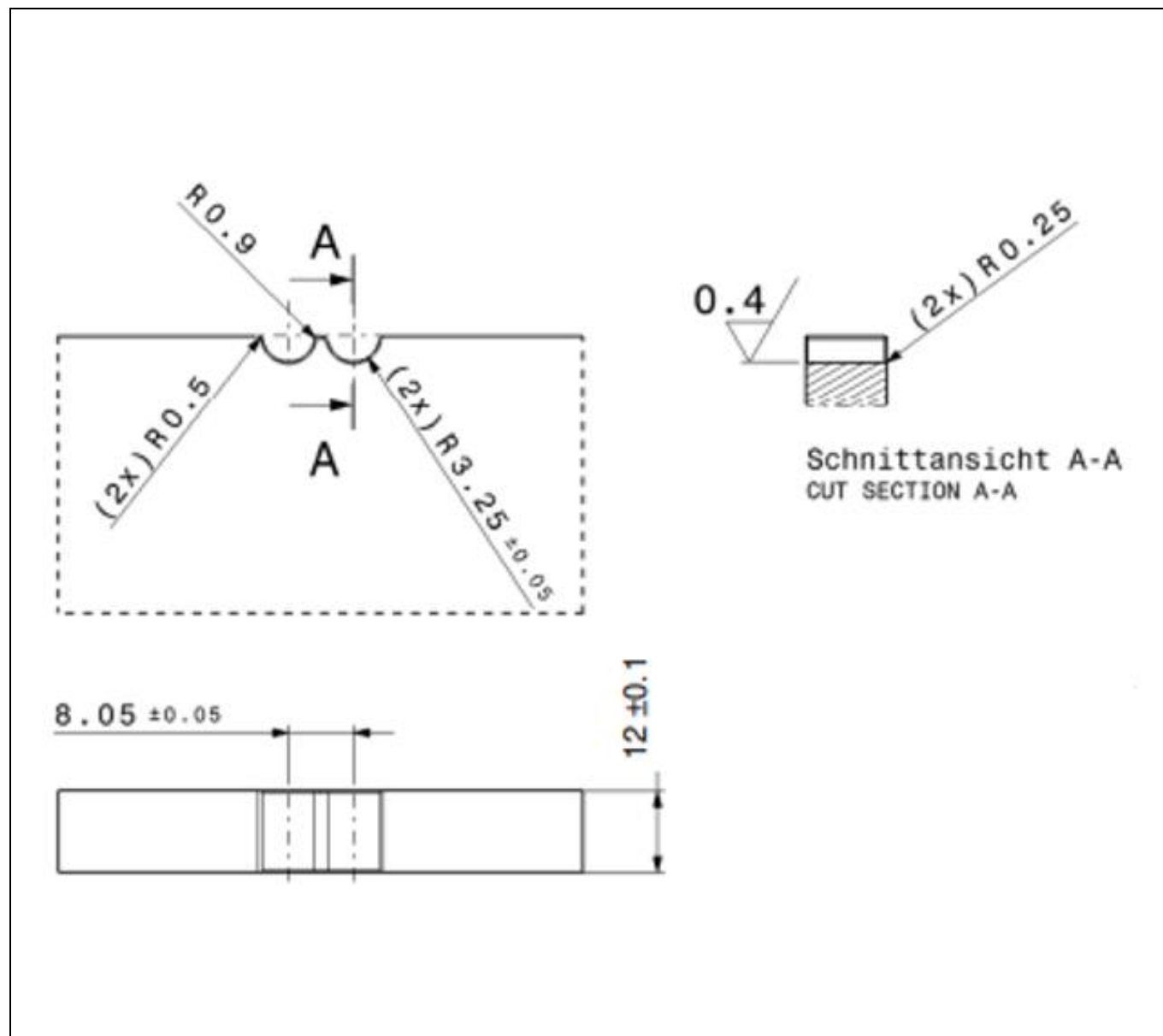

Description	Version	Material
Plunger and anvil	B	1.2721 vacuum hardened 58hrc



The plunger and the anvil must be set to each other in such a way that the dimension D11 results after crimping.

In “**Table 3.10**”, dimension D11 is specified for the plunger and anvil version A, as shown in “**Figure 3.39**”. The plunger and anvil version A may only be used in conjunction with system number 809-887-001 and the cable listed in “**Table 3.10**”.

Table 3.10: Overview 4.0 mm² SCC dimension D11, plunger and anvil version A for 809-887-001 (3.10.1 Cable shielding crimping using two half-shells)

Cable manufacturer	Cable type	According Chapter 1.6	Cable cross section	Dimension D11
Coficab	FHLR91XCB91X T4 PSA	C	4.0 mm ²	6.15 ± 0.1 mm

In “**Table 3.11**”, dimension D11 is specified for the plunger and anvil version B, as shown in “**Figure 3.40**”. The plunger and anvil version B may only be used in conjunction with system number 807-655-... and the cable listed in “**Table 3.11**”.

Table 3.11: Overview 4.0 mm² SCC dimension D11, plunger and anvil version B for 807-655-... (3.10.1 Cable shielding crimping using two half-shells)

Cable manufacturer	Cable type	According Chapter 1.6	Cable cross section	Dimension D11
Coficab	FHLR91XCB91X T4 PSA	C	4.0 mm ²	6.8 ± 0.1 mm
Coroflex	FHLR2GCB2G 4.0 mm ² / 0.21 T180	D	4.0 mm ²	6.8 ± 0.1 mm
Gebauer & Griller	FHLR2GCB2G 1x4.0/T180 OR	O	4.0 mm ²	6.8 ± 0.1 mm
Huber & Suhner	FHLR91XC13X-1x4 T150	B	4.0 mm ²	6.8 ± 0.1 mm
Leoni	FHLR2GCB2G 4,0/0,31/T180	F	4.0 mm ²	6.8 ± 0.1 mm
Aptiv	FHLR91XC91X-B 4.0mm ²	Q	4.0 mm ²	6.8 ± 0.1 mm

To check the dimension D11, the measurement must be carried out with a suitable measuring instrument, as shown in “**Figure 3.44**”. To prevent measurement in the embossing groove depending on the plunger and anvil version, the width of the measuring instrument must be 3.5 ± 0.5 mm, as shown in “**Figure 3.41**”.

Figure 3.41: Representation 4.0 mm² SCC width of measuring instrument for dimension D11 (3.10.1 Cable shielding crimping using two half-shells)

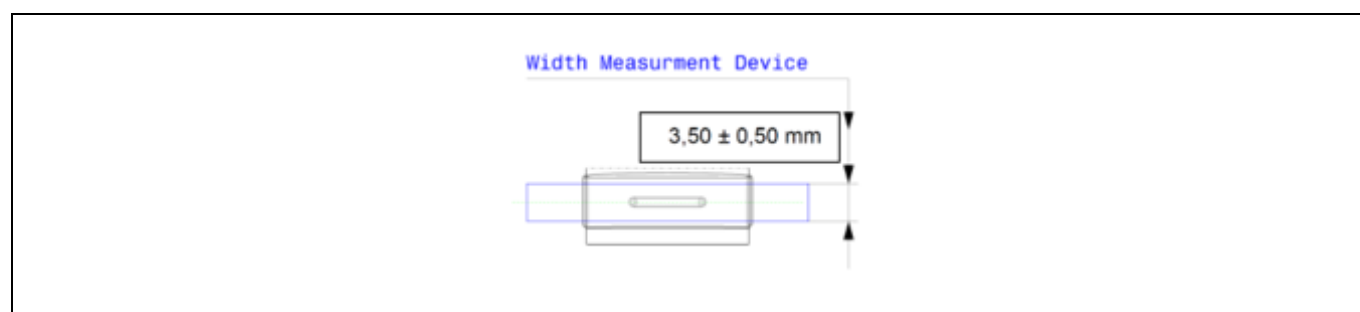

By crimping the shielding sleeve, a fold is created on both sides, as shown in “**Figure 3.42**”. The resulting dimension D12, as shown in “**Figure 3.44**”, is specified in “**Table 3.12**”. It must be ensured that the material of the shielding sleeve is not torn in the area of the fold.

Figure 3.42: Representation 4.0 mm² SCC shielding sleeve fold (3.10.1 Cable shielding crimping using two half-shells)



Table 3.12: Overview 4.0 mm² SCC dimension D12 (3.10.1 Cable shielding crimping using two half-shells)

Cable cross section	Dimension D12
4.0 mm ²	max. 17.2 mm

To check dimension D12, as shown in “**Figure 3.44**”, a gauge with a maximum inside diameter of 17.2 mm must be used. The measurement must be taken across the entire area depicted in “**Figure 3.43**”.

Figure 3.43: Representation 4.0 mm² SCC measurement area dimension D12 (3.10.1 Cable shielding crimping using two half-shells)

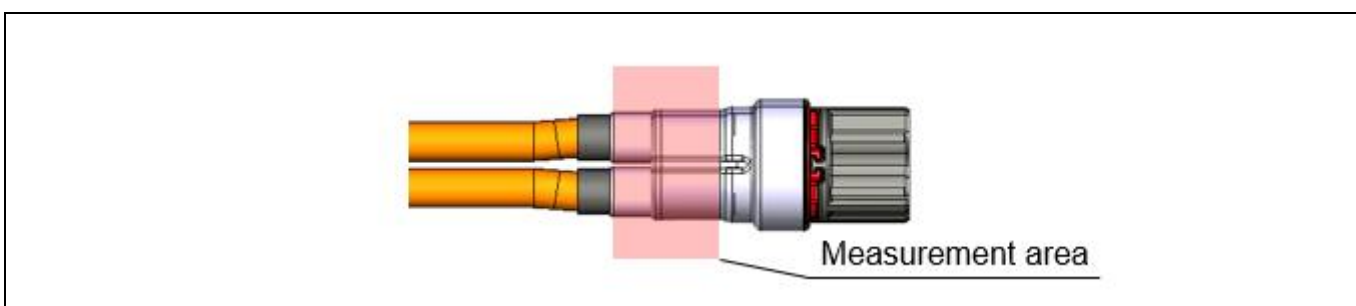
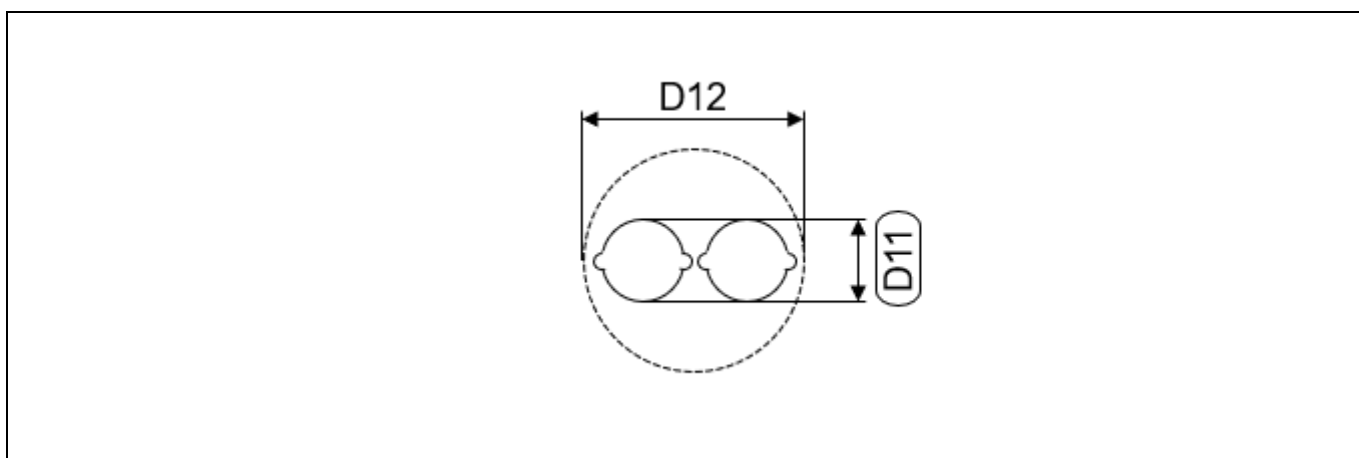
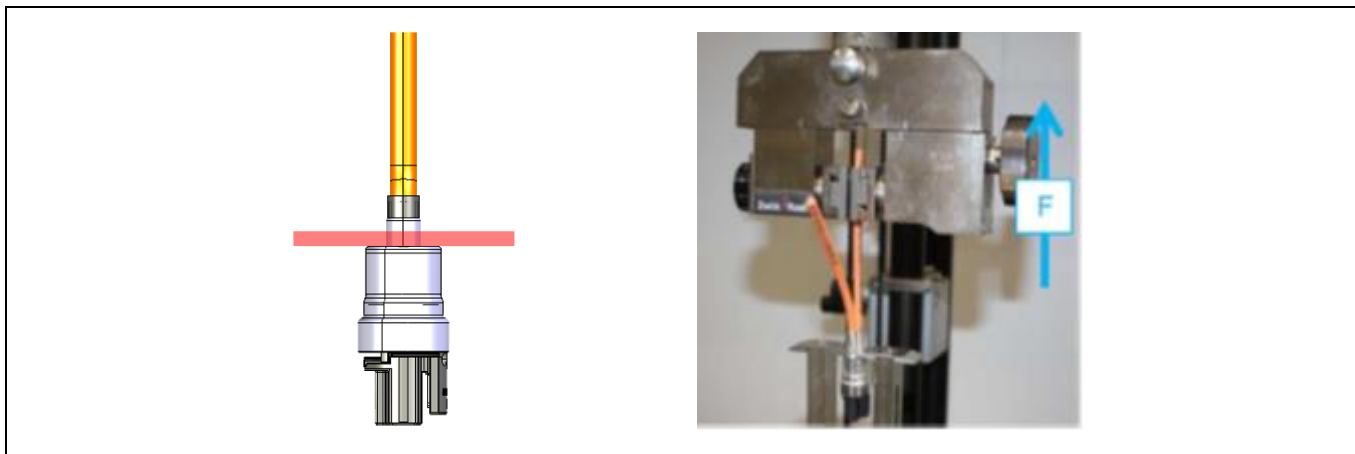

Figure 3.44: Representation 4.0 mm² SCC dimension D11 and D12 (3.10.1 Cable shielding crimping using two half-shells)



To measure the pull-off force, the cable must be securely clamped in a tensioning device. The distance between the clamping position of the cable and the fixing tape should be approximately 70.0 mm. The connector must be gripped on the shielding sleeve in the area shown in “**Figure 3.45**”. The testing must be conducted with an individual cable, as shown in “**Figure 3.45**”.

Figure 3.45: Representation 4.0 mm² SCC pull-off force clamping position shielding sleeve (3.10.1 Cable shielding crimping using two half-shells)



To ensure a correct inspection of the cable shielding compression, no HCT4 female terminals should be installed in the test specimens, as this would distort the measurement results. Further options for constructing the test specimens are shown in **Chapter “7.4 Sample preparation for shielding retention force”**. The required pull-off forces are shown in “**Table 3.13**”. The pull-off force is a special **(L2)** characteristic according to the **Chapter “1.7 Characteristics and customer approvals”**.

Table 3.13: Overview 4.0 mm² SCC pull-off force shielding sleeve (3.10.1 Cable shielding crimping using two half-shells)

Cable manufacturer	Cable type	According Chapter 1.6	Cable cross section	Pull-off force
Coficab	FHLR91XCB91X T4 PSA	C	4.0 mm ²	≥ 150.0 N
Coroflex	FHLR2GCB2G 4.0 mm ² / 0.21 T180	D	4.0 mm ²	≥ 150.0 N
Gebauer & Griller	FHLR2GCB2G 1x4.0/T180 OR	O	4.0 mm ²	≥ 150.0 N
Huber & Suhner	FHLR91XC13X-1x4 T150	B	4.0 mm ²	≥ 150.0 N
Leoni	FHLR2GCB2G 4,0/0,31/T180	F	4.0 mm ²	≥ 150.0 N
Aptiv	FHLR91XC91X-B 4.0mm ²	Q	4.0 mm ²	≥ 150.0 N

3.10.2 Crimp the contact carrier

This chapter describes the position of the crimping tool, the geometries of the plunger and anvil, and the resulting crimp dimensions of the contact carrier crimping. The position of the plunger and anvil refers to the front surface of the contact carrier, as shown in “**Figure 3.46**”. The dimension D13, as listed in “**Table 3.14**”, indicates the position of the plunger and anvil. The four embossing positions (a-d) must be aligned towards the contact carrier. For this, the contact carrier must be secured against rotation. The green areas, as shown in “**Figure 3.46**”, can be used as a holder for the contact carrier. The embossing must be performed simultaneously.

Figure 3.46: Representation 4.0 mm² SCC dimension D13 and embossing positions a-d (3.10.2 Crimp the contact carrier)

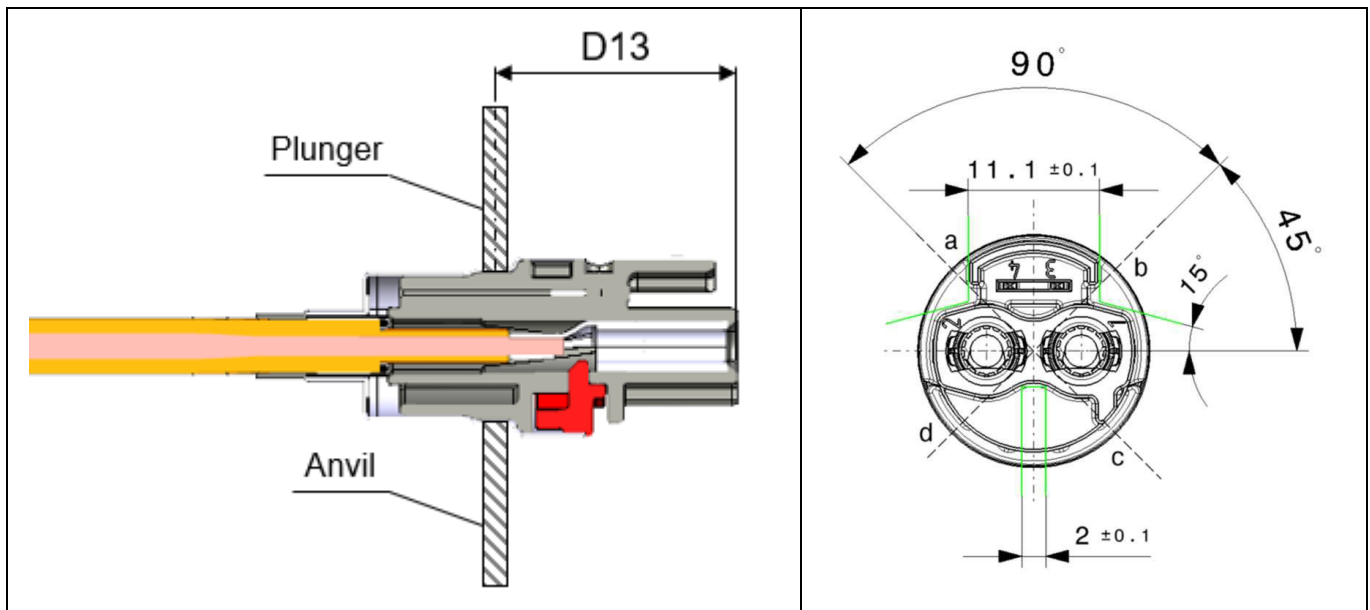

Table 3.14: Overview 4.0 mm² SCC dimension D13 (3.10.2 Crimp the contact carrier)

Dimension D13
25.3 ± 0.1 mm



The exact geometry of the plunger and anvil is shown in “Figure 3.47”.

Figure 3.47: Representation 4.0 mm² SCC plunger and anvil (3.10.2 Crimp the contact carrier)

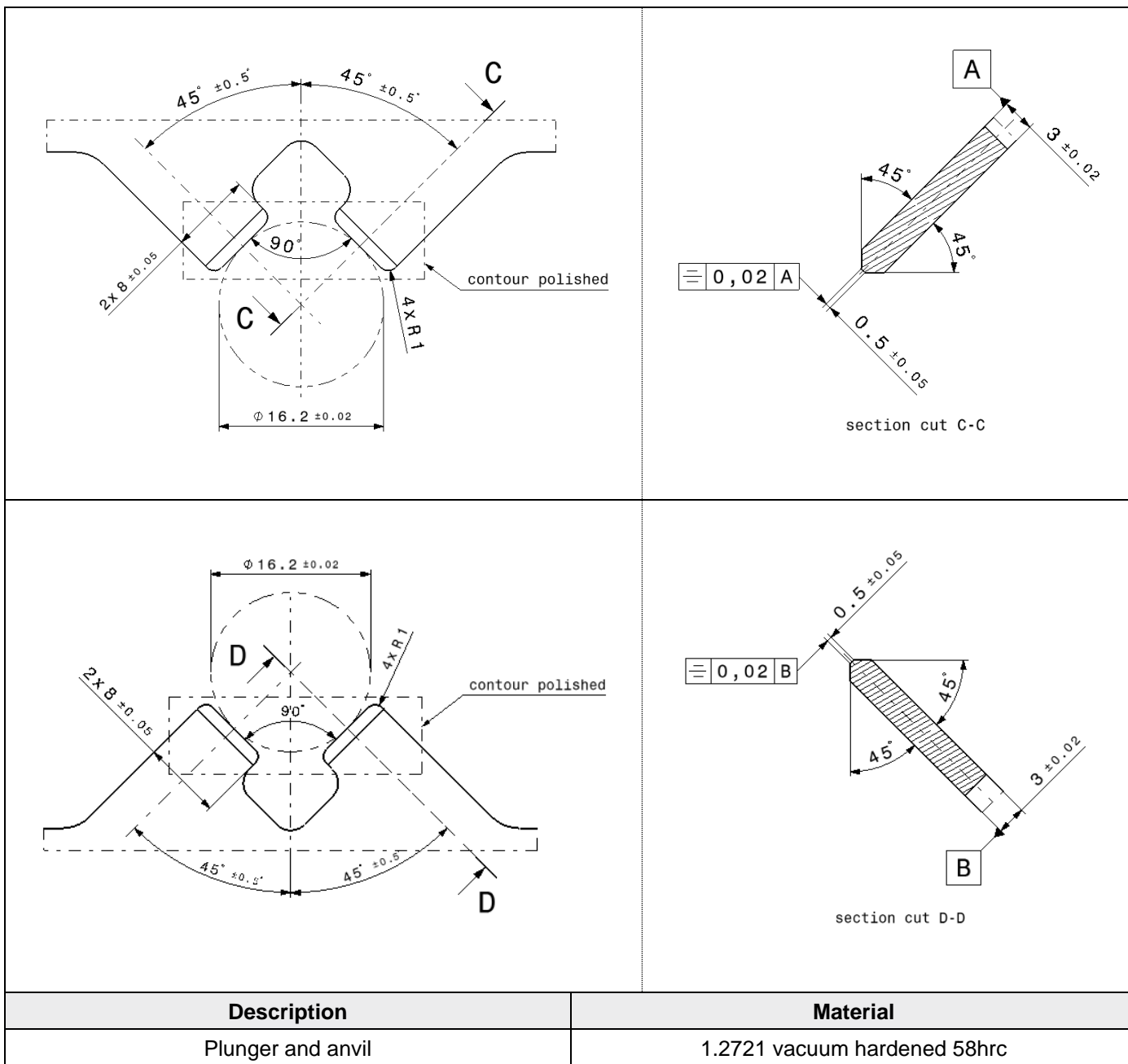

The dimension D14, which is listed in “**Table 3.15**”, results from the embossing between plunger and anvil, or a-c and b-d. To check the dimension D14, as shown in “**Figure 3.48**”, measurement must be taken in the embossing grooves. The measurement must be carried out with a suitable measuring instrument, and the measuring pickup must be < 0.6 mm in order for the measurement to be conducted.

Figure 3.48: Representation 4.0 mm² SCC dimension D14 (3.10.2 Crimp the contact carrier)

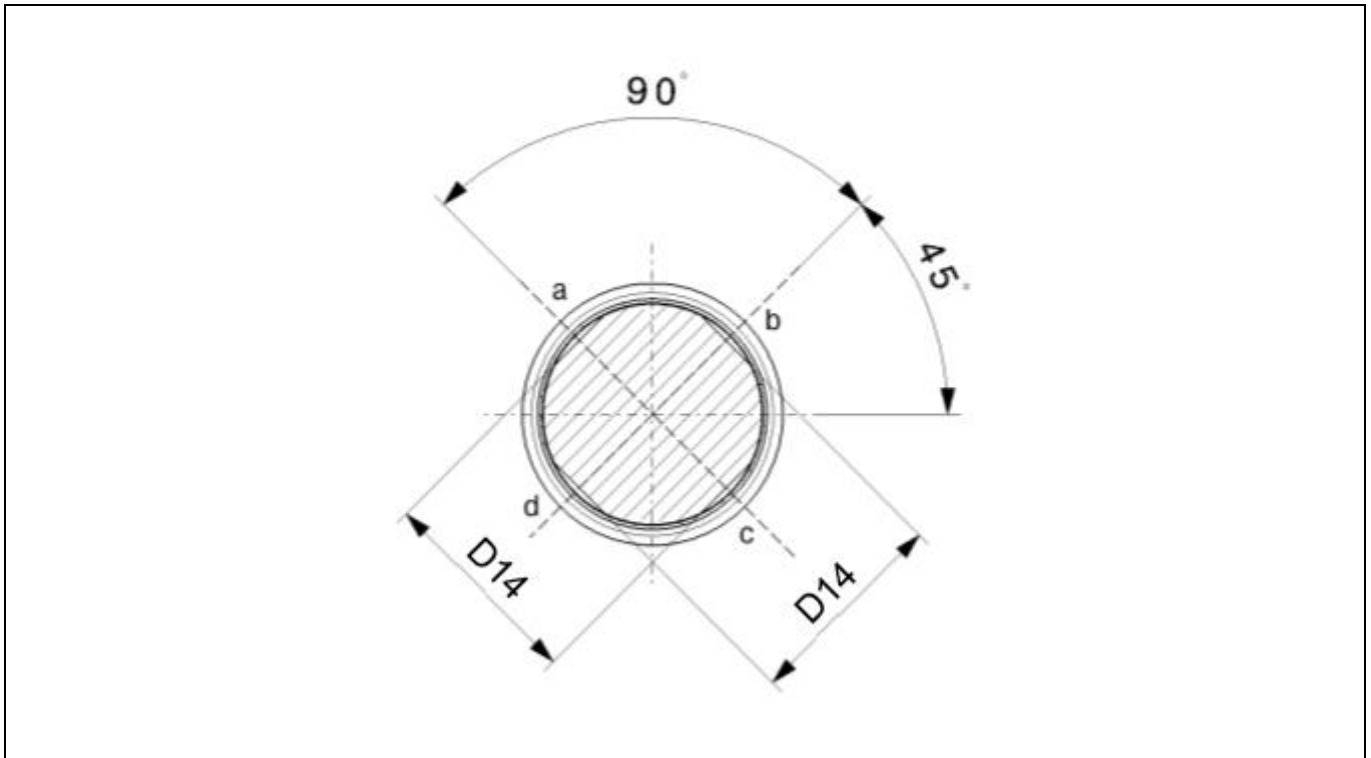

Table 3.15: Overview 4.0 mm² SCC dimension D14 (3.10.2 Crimp the contact carrier)

Dimension D14
16.4 ± 0.1 mm

3.11 Optional fixation of the cables

In this process step, the cables are connected to each other using a tool, as shown in “**Figure 3.49**”, to ensure that the welds are not damaged during a load on the individual shielding sleeves. In this specification, the PET fabric adhesive tape 837X (838X) with a width of 5.0 mm from Coroplast was used, as shown in “**Figure 3.16**”. If necessary, another suitable tool can be used. The tool for fixation must have a temperature resistance of at least 150°C.

Figure 3.49: Representation 4.0 mm² SCC optional fixation of the cables (3.11 Optional fixation of the cables)



The measurement from the front surface of the contact carrier to the end of the fastening material must be a maximum of 52.0 mm, as shown in “**Figure 3.50**”.

Figure 3.50: Representation 4.0 mm² SCC optional fixation of the cables max. 52.0 mm (3.11 Optional fixation of the cables)

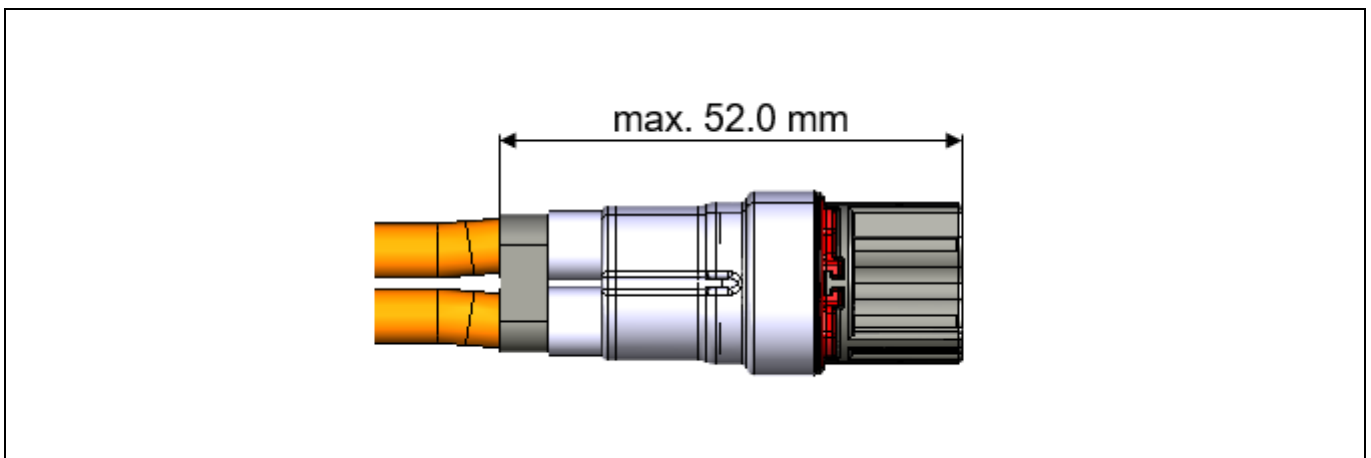

This step can be omitted if it is ensured that the cables are not pulled apart in subsequent processes.

4 Processing steps 6.0 mm² SCC

In this chapter, the necessary process steps for assembling the HPS40-2 2+2 female connector 6.0 mm² SCC are described. The example images depict the contact carrier with coding A, along with all the necessary components for a 6.0 mm² cable.

4.1 Cutting the cable

In this process step, the cable is cut to the required length. An additional length of cable is needed for the assembly of the connector, and this is specified in “**Table 4.1**”.

Figure 4.1: Representation 6.0 mm² SCC cable example (4.1 Cutting the cable)

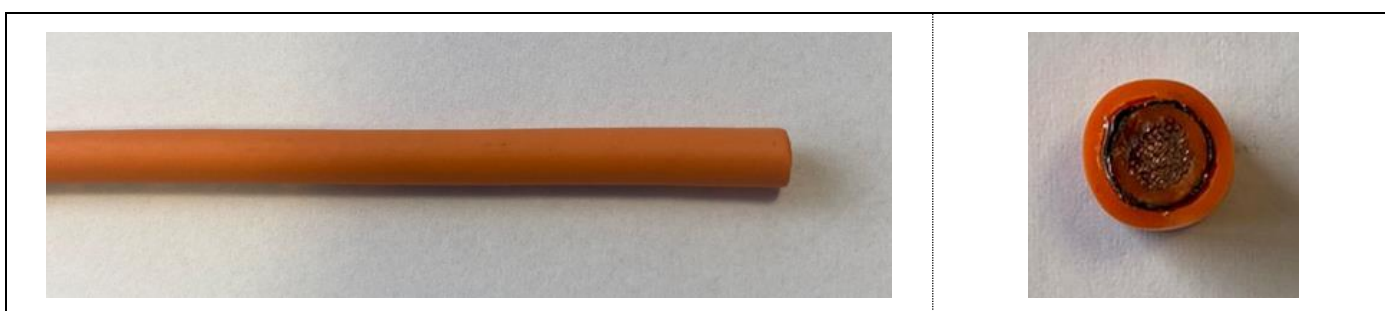

Figure 4.2: Representation 6.0 mm² SCC dimension X1 and dimension D15 (4.1 Cutting the cable)

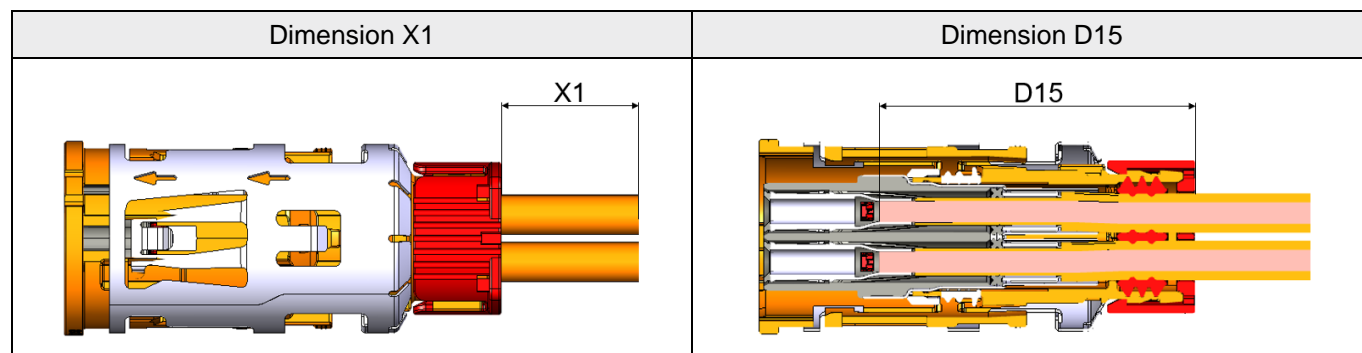

Table 4.1: Overview 6.0mm² SCC dimension D15 (4.1 Cutting the cable)

Cable cross section	Dimension D15
6.0 mm ²	50.0 mm

The dimension X1 exemplarily represents the cable length of the cable assembly and varies depending on the overall length of the cable assembly. Dimension D15 must be added to dimension X1 because the length of dimension D15 is needed for the assembly of the connector.

In the case of using equipment with zero trim for following processes, it should be noted that the dimension for the zero trim must be added to the dimension D15. The exact length of the zero trim varies, as each piece of equipment performing a zero trim may cut different lengths.

4.2 Assemble individual components

During this process step, the initial required individual components are assembled in the order of the cover cap (1), cable seal (2), locking sleeve (3), and shielding sleeve (4) according to **“Figure 4.3”**. For the cable seal (2), locking sleeve (3), and shielding sleeve (4), no specific orientation is required, they can be assembled in any orientation.

Figure 4.3: Representation 6.0 mm² SCC assemble individual components (4.2 Assemble individual components)

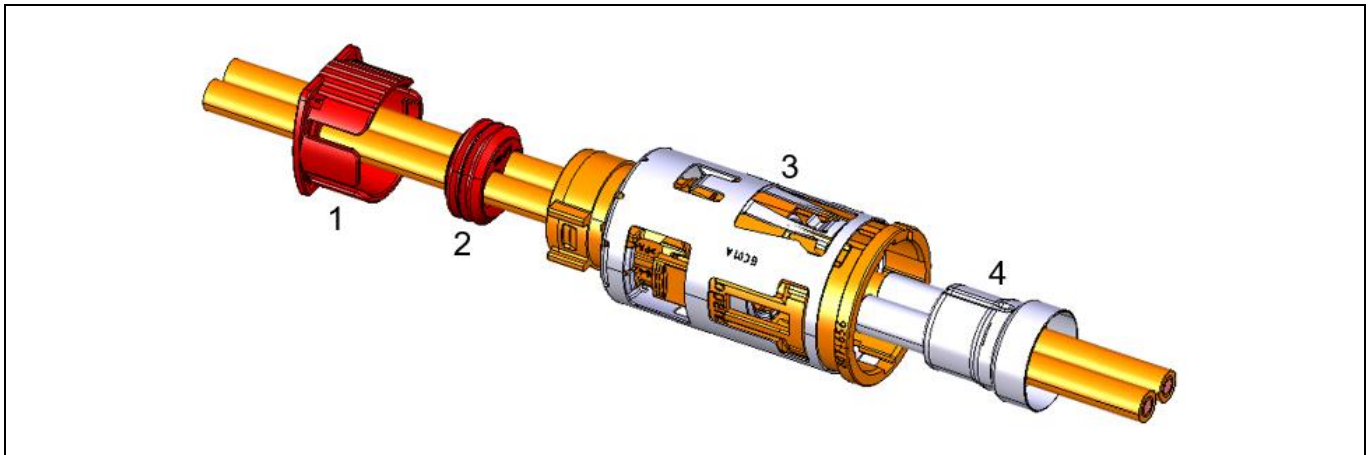

The cable seal may be slightly expanded during assembly.

The locking sleeve (3) and the shielding sleeve (4) can also be assembled onto the cable after the crimping process of the HCT4 female terminals, which is described in **Chapter “4.5 Crimp the HCT4 female terminal”**.

If the HPS40-2 2+2 cover cap 6.0 mm² SCC non-polarized (706-822-505) according to **“Figure 2.9”** is used, no specific orientation is required, it can be assembled in any orientation.

If the HPS40-2 2+2 cover cap 6.0 mm² SCC polarized (706-430-505) according to **“Figure 2.10”** is used, pay attention to the pin assignment as shown in **“Figure 4.4”**, as it cannot be rotated afterwards.

Figure 4.4: Representation 6.0 mm² SCC pin assignment HPS40-2 2+2 cover cap 6.0 mm² SCC polarized (4.2 Assemble individual components)

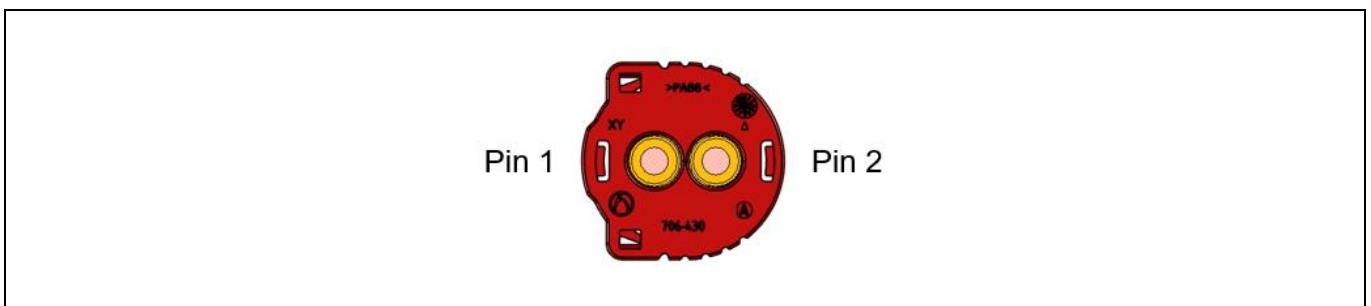

4.3 Strip off the cable

In this process step, the cable is stripped to the required length specified in “**Table 4.2**”.

Figure 4.5: Representation 6.0 mm² SCC stripped off cable example (4.3 Strip off the cable)



Figure 4.6: Representation 6.0 mm² SCC dimension D16 (4.3 Strip off the cable)

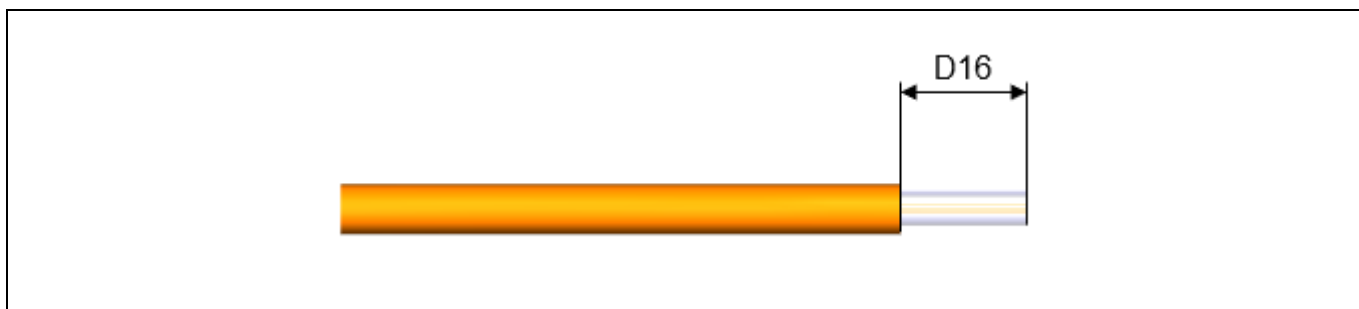

Table 4.2: Overview 6.0mm² SCC dimension D16 (4.3 Strip off the cable)

Cable cross section	Dimension D16
6.0 mm ² (Cu)	30.5 ± 1.0 mm
6.0 mm ² (Al)	29.5 ± 1.0 mm

4.4 Remove shielding foil (if present), trim shielding braid, and assembly the stress relief and X-Ring

In this process step, the shielding foil is removed (if present), the shielding braid is shortened, and the stress relief and the X-ring are mounted on the cable, as shown in **“Figure 4.7”**. The processor can determine the order of these processes themselves.

Figure 4.7: Representation 6.0 mm² SCC remove shielding foil (if present), trim shielding braid, and crimp the ferrule crimp (4.4 Remove shielding foil (if present), trim shielding braid, and assembly the stress relief and X-Ring)



The shielding braid must be shortened to the dimension specified in **“Table 4.3”**.

Figure 4.8: Representation 6.0 mm² SCC dimension D17 (4.4 Remove shielding foil (if present), trim shielding braid, and assembly the stress relief and X-Ring)

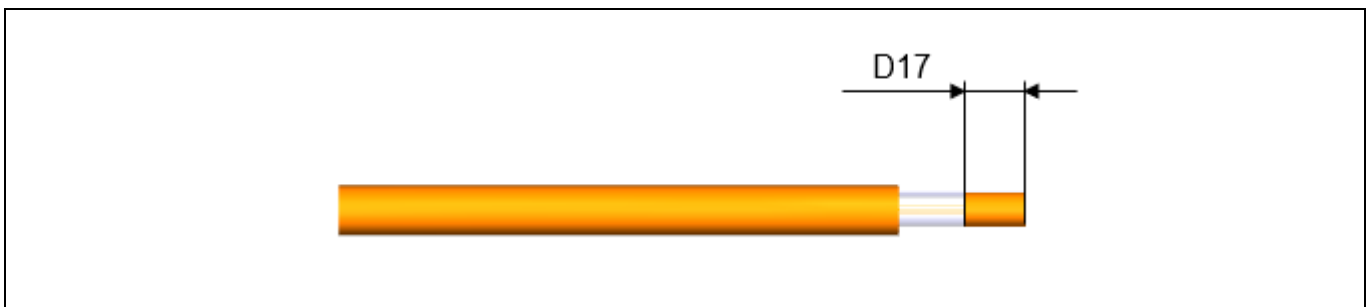

Table 4.3: Overview 6.0 mm² SCC dimension D17 (4.4 Remove shielding foil (if present), trim shielding braid, and assembly the stress relief and X-Ring)

Cable cross section	Dimension D17
6.0 mm ² (Cu)	22.6 ± 1.0 mm
6.0 mm ² (Al)	21.6 ± 1.0 mm

After trimming the shielding braid, no cable strands or remnants of the shielding braid are allowed on the cable. These residues must be removed by suitable methods such as blowing or suction.



If a shielding foil is present, a circumferential protrusion in the area of the shielding braid of a maximum of 1.0 mm is permissible, as shown in **“Figure 4.9”**. Non-circumferential individual tears ≤ 3.0 mm are also permissible.

Figure 4.9: Representation 6.0 mm² SCC overhang shielding foil (4.4 Remove shielding foil (if present), trim shielding braid, and assembly the stress relief and X-Ring)



To mount the stress relief, the shielding braid must be slightly spread apart, as shown in **“Figure 4.10”**. The stress relief must be pushed up to the stop of the cable.

Figure 4.10: Representation 6.0 mm² SCC assemble the stress relief (4.4 Remove shielding foil (if present), trim shielding braid, and assemble the stress relief and X-Ring)

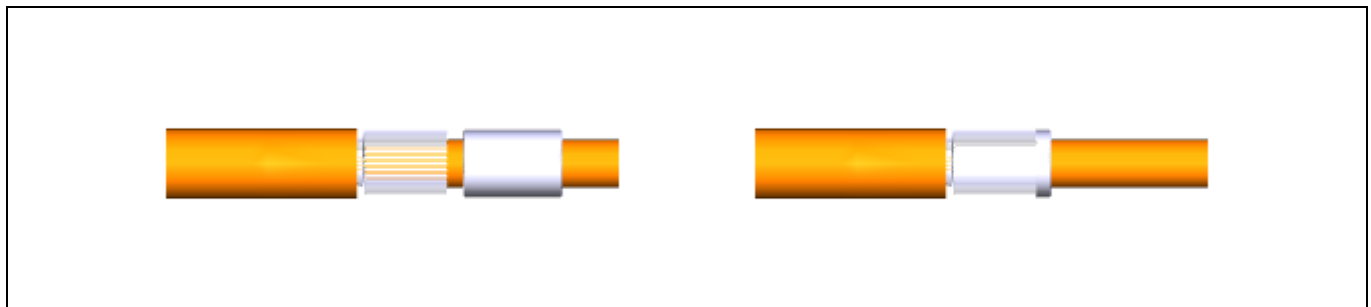

The stress relief must be fixed with the X-ring, as shown in **“Figure 4.11”**. The X-ring must be pushed up to the stop of the stress relief.

Figure 4.11: Representation 6.0 mm² SCC assemble the X-Ring (4.4 Remove shielding foil (if present), trim shielding braid, and assemble the stress relief and X-Ring)

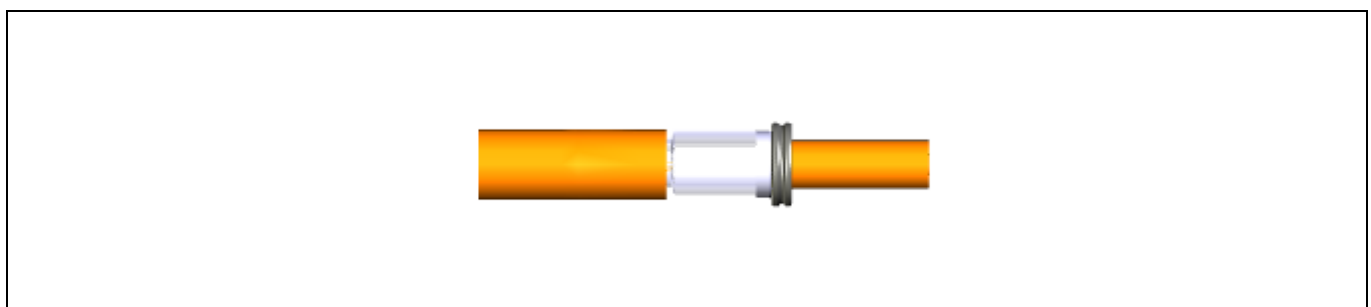



The assembly of the stress relief and the X-ring can be done in one step. The dimension D18, as listed in “**Table 4.4**”, ensures the correct position of the stress relief and the X-ring.

Figure 4.12: Representation 6.0 mm² SCC dimension D18 (4.4 Remove shielding foil (if present), trim shielding braid, and assemble the stress relief and X-Ring)



Table 4.4: Overview 6.0 mm² SCC dimension D18 (4.4 Remove shielding foil (if present), trim shielding braid, and assemble the stress relief and X-Ring)

Cable cross section	Dimension D18
6.0 mm ² (Cu)	19.2 ± 1.0 mm
6.0 mm ² (Al)	18.2 ± 1.0 mm

4.5 Crimp the HCT4 female terminal

In this process step, the HCT4 female terminal is crimped onto the cable as shown in “**Figure 4.13**”. The crimp data can be found in the process specification HCT4 female terminal EVS-100068. If the contact carriers HPS40-2 2+2 female contact carrier 4.0 mm² & 6.0 mm² SCC which are listed in “**Figure 2.3**” are used, the stripping length mentioned in the EVS-100068 can be extended by a maximum of 2.0 mm.

Figure 4.13: Representation 6.0 mm² SCC crimped HCT4 female terminal (4.5 Crimp the HCT4 female terminal)



The HCT4 female terminal must be crimped parallel to the cable.

The dimensions D19, D20 and D21, as shown in “**Figure 4.14**”, result from the dimensions D16, D18, and EVS-100068. A mark on the insulation of the individual cable or on the outer sheath caused by fixing the cable during the crimping process is allowed. However, it must be ensured that the insulation is not damaged (torn, penetrated, etc.), as this would lead to an insulation failure. The required dimensions are specified in “**Table 4.5**”.

Figure 4.14: Representation 6.0 mm² SCC dimension D19, D20 and D21 (4.5 Crimp the HCT4 female terminal)

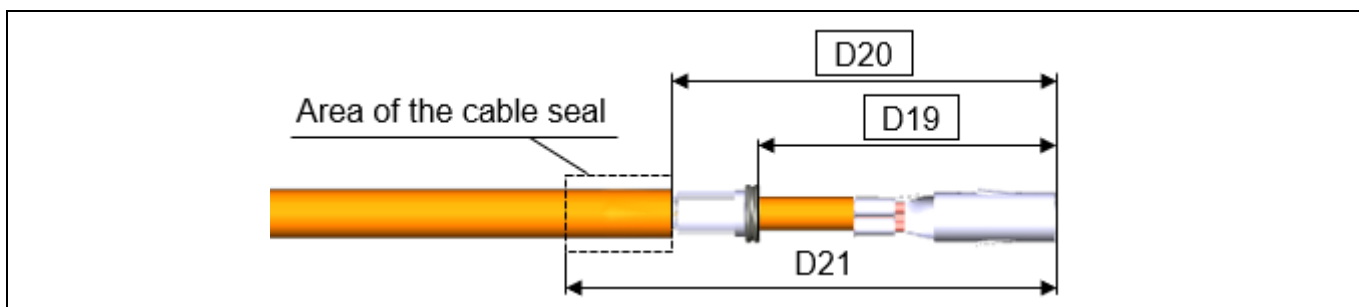

Table 4.5: Overview 6.0 mm² SCC dimension D19, D20 and D21 (4.5 Crimp the HCT4 female terminal)

Cable cross section	Dimension D19	Dimension D20	Dimension D21
6.0 mm ²	35.95 ± 0.95 mm	47.25 ± 2.0 mm	max. 67.0 mm

At the area of the cable seal, it is not allowed to deform or damage the outer sheath, as this can have a negative impact on the sealing function. If agreed upon by the OEM, either D18 or D19 and D16 or D20 must be proven, as they correlate.



4.6 Inserting HCT4 female terminals into the contact carrier

In this process step, the cables with the crimped HCT4 female terminals are assembled into the contact carrier as shown in “**Figure 4.15**”. If two cables with the same color are used, the pinning must be confirmed by electrical testing.

While populating the HCT4 female terminals into the contact carrier, the latching lance of the HCT4 female terminals is deflected. Once the end position is reached, the latching lance audibly engages, and the HCT4 female terminals are primary locked.

Figure 4.15: Representation 6.0 mm² SCC inserting into the contact carrier (4.6 Inserting HCT4 female terminals into contact carrier)

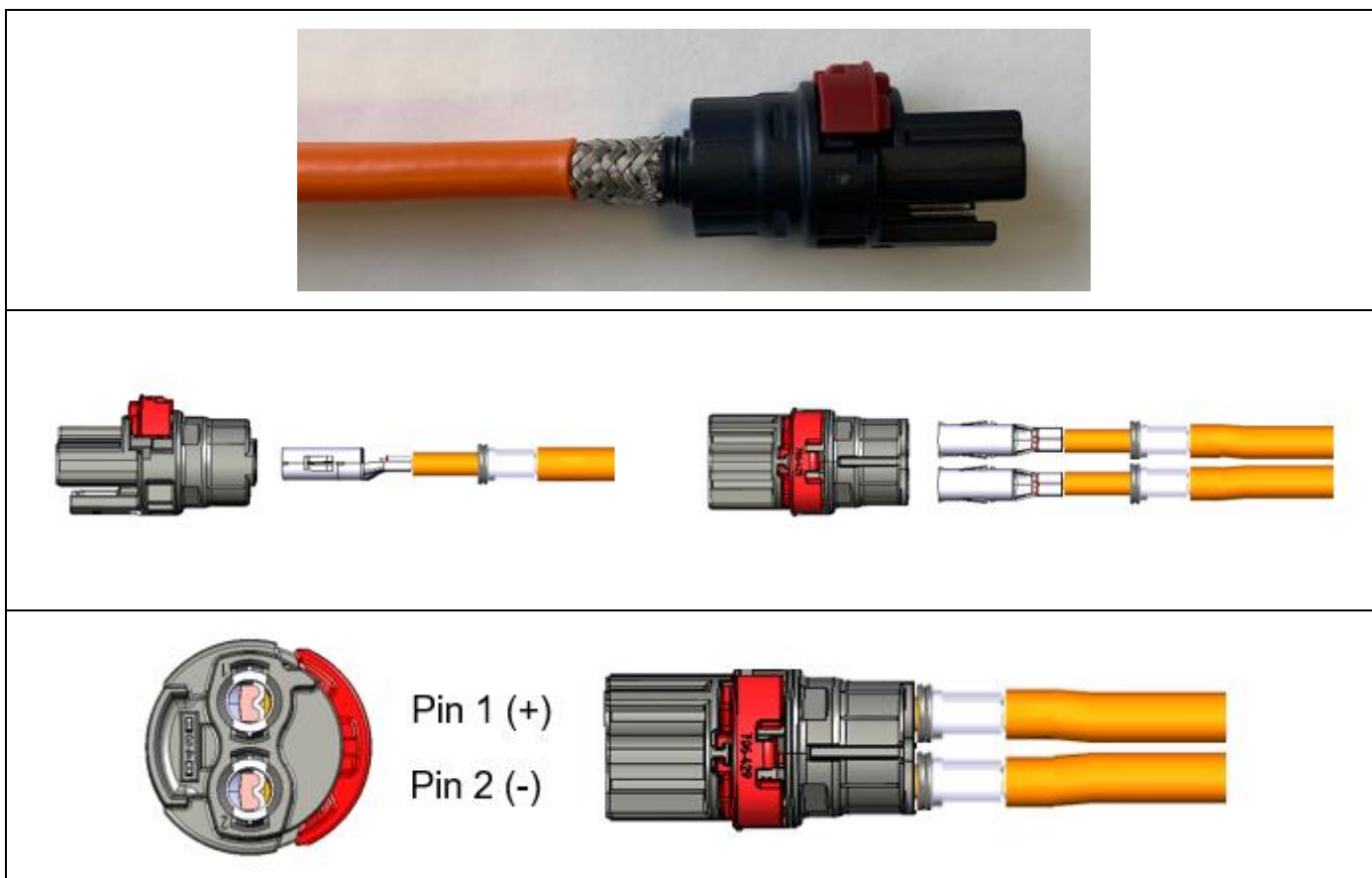

The allowed angular deviation when inserting the HCT4 female terminals, as shown in “**Figure 4.16**”, results from the geometry of the lead-in chamfers on the contact carrier and the maximum permissible assembly force of the cables with the HCT4 female terminals into the contact carrier, which are listed in “**Table 4.6**”.

Figure 4.16: Representation 6.0 mm² SCC lead-in chamfers contact carrier (4.6 Inserting HCT4 female terminals into contact carrier)

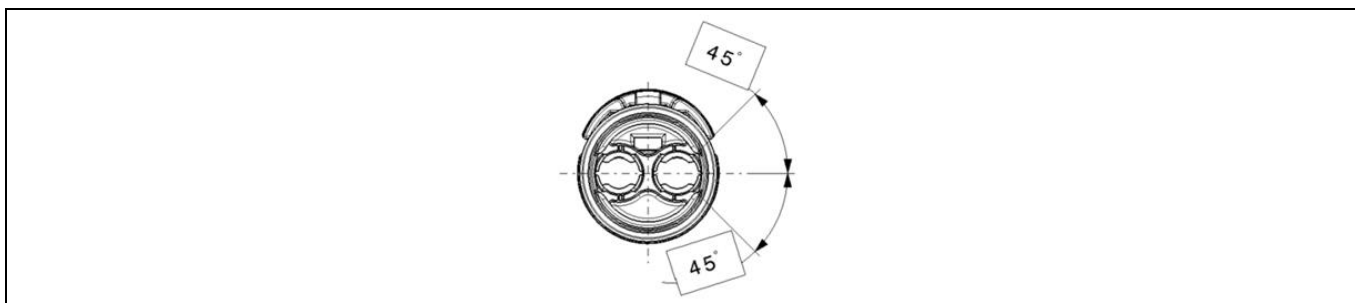

In order to ensure that the end position of the HCT4 female terminals in the contact carrier is achieved, either the mounting force or the attainment of the end position must be proven. This is only relevant if the mounting of the HCT4 female terminals into the contact carrier is not performed fully automatically. In fully automatic assembly solutions, these functions can be integrated into the machine. The maximum permissible assembly force is shown in “**Table 4.6**”.

Table 4.6: Overview 6.0 mm² SCC maximum permissible assembly force (4.6 Inserting HCT4 female terminals into contact carrier)

Cable manufacturer	Cable type	According Chapter 1.6	Cable cross section	Maximum force
Coficab	FHLR91XCB91X T4	G	6.0 mm ²	36.0 N
Coficab	FHLR91XC91X T4 ISO	M	6.0 mm ²	36.0 N
Coroflex	FHLR2GCB2G 6.0 mm ² / 0.21 T180	H	6.0 mm ²	36.0 N
Gebauer & Griller	FHLR2GCB2G 1x6.0/T180 OR	N	6.0 mm ²	36.0 N
Kroschu	FHLR2GCB2G 6.00 QMM/0.21/T180	I	6.0 mm ²	36.0 N
Leoni	FHLR2GCB2G 6,0/0,31/T180	J	6.0 mm ²	36.0 N
Aptiv	FHLR91XC91X-C	P	6.0 mm ²	36.0 N



If the HCT4 female terminals are assembled incorrectly into the contact carrier, this can cause a plastic burr inside the contact carrier chamber and the HCT4 female terminals, as shown in “**Figure 4.17**”. These contact carriers must no longer be used and must be scrapped.

Figure 4.17: Representation 6.0 mm² SCC plastic burr on contact carrier (4.6 Inserting HCT4 female terminals into contact carrier)



The HCT4 female terminals must also be checked for plastic burrs and cleaned before further assembly. If cleaning does not remove all residual plastic, the HCT4 female terminals must also be scrapped.



4.7 Close secondary lock on the contact carrier

In this process step, the secondary lock on the contact carrier is closed, as shown in “**Figure 4.18**”.

Figure 4.18: Representation 6.0 mm² SCC close secondary lock on the contact carrier (4.7 Close secondary lock on the contact carrier)



The secondary lock can only be closed when the HCT4 female terminals are in the end position. A possible visible positional difference of the HCT4 female terminals in the contact carrier chamber to each other may result from the HCT4 female terminal position on the cable and the locking play of the HCT4 female terminals in the contact carrier chamber and is permissible. The pre-locking and locking positions of the secondary lock on the contact carrier are shown in “**Figure 4.19**”. In the pre-locking position of the secondary lock on the contact carrier, the HCT4 female terminals are only primarily locked. In the locking position of the secondary lock on the contact carrier, the HCT4 female terminals are both primarily and secondarily locked.

Figure 4.19: Representation 6.0 mm² SCC pre-locking and locking position secondary lock (4.7 Close secondary lock on the contact carrier)

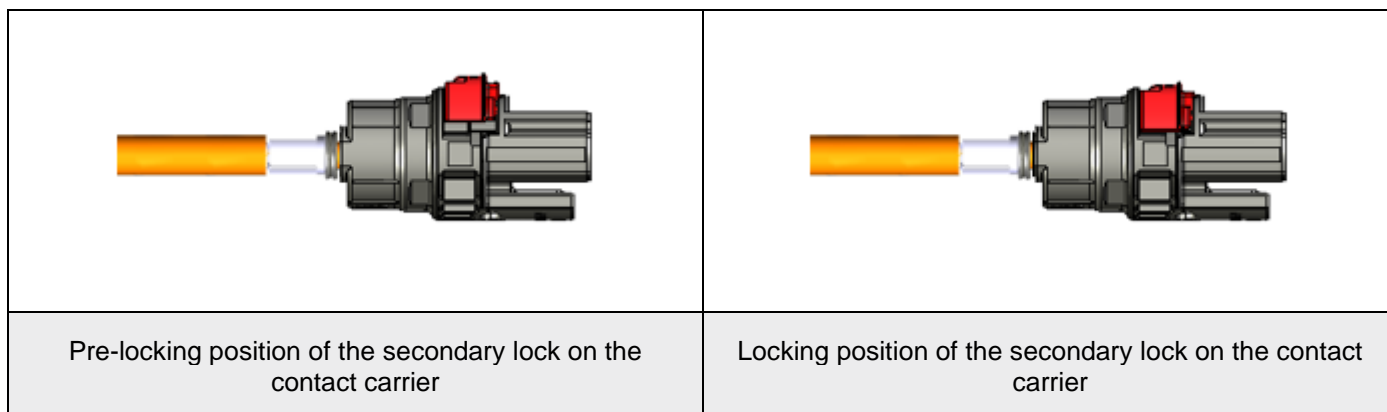



4.8 Slide the shielding sleeve onto the contact carrier

In this process step, the shielding sleeve is slid onto the contact carrier; as shown in “**Figure 4.20**”.

Figure 4.20: Representation 6.0 mm² SCC slide the shielding sleeve onto the contact carrier (4.8 Slide the shielding sleeve onto the contact carrier)



The cables must be secured during this process to prevent the cables and/or the stress relief from being compressed or pushed inside the connector, as this can cause damage to the insulation (“**Figure 4.21**”) and thus lead to dielectric breakdown. Neither the cables nor any other component may be damaged by the clamping process.

Figure 4.21: Representation 6.0 mm² SCC risk of insulation failure (4.8 Slide the shielding sleeve onto the contact carrier)



**Risk of insulation failure!
The components must not be damaged.**

The shielding sleeve must be slid onto the contact carrier in a polarized manner using the two existing polarization grooves on both the shielding sleeve and the contact carrier, as shown in “**Figure 4.22**”. The shielding sleeve is a symmetrical component and can therefore be mounted in two positions, rotated by 180°. This means that it is not necessary to pay attention to which polarization groove of the shielding sleeve is used with the polarization groove of the contact carrier.

Figure 4.22: Representation 6.0 mm² SCC polarization shielding sleeve and contact carrier (4.8 Slide the shielding sleeve onto the contact carrier)

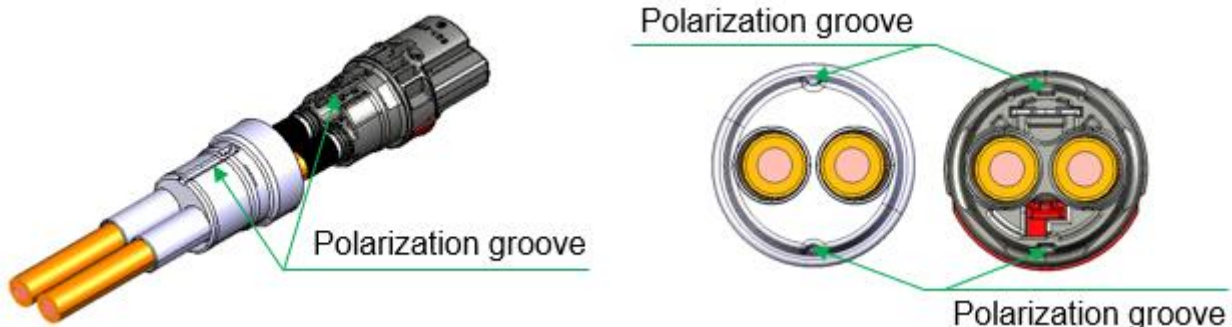



The shielding sleeve must be pushed forward until it abuts against the collar of the contact carrier, as shown in **“Figure 4.23”**.

Figure 4.23: Representation 6.0 mm² SCC end position shielding sleeve on contact carrier (4.8 Slide the shielding sleeve onto the contact carrier)

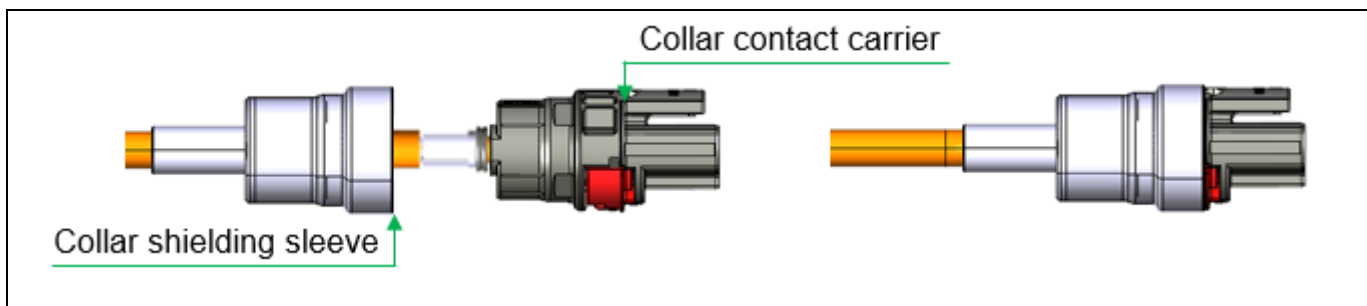

It must be ensured that no individual shielding strands protrude before the shielding sleeve is mounted, as shown in **“Figure 4.24”**. If necessary, protruding individual shielding strands can be removed. This rework must be clarified with the respective OEM.

Figure 4.24: Representation 6.0 mm² SCC protruded individual shielding strands (4.8 Slide the shielding sleeve onto the contact carrier)



The implemented assembly process can be verified using X-ray analysis, as shown in **“Figure 4.25”**. This allows for confirmation of cable compression, strain relief positioning, and positioning of the X-ring, as well as checking other impacts of this and previous assembly steps. Deviations from this depiction must be reviewed in consultation with Hirschmann Automotive GmbH.

Figure 4.25: Representation 6.0 mm² SCC X-ray analysis (4.8 Slide the shielding sleeve onto the contact carrier)

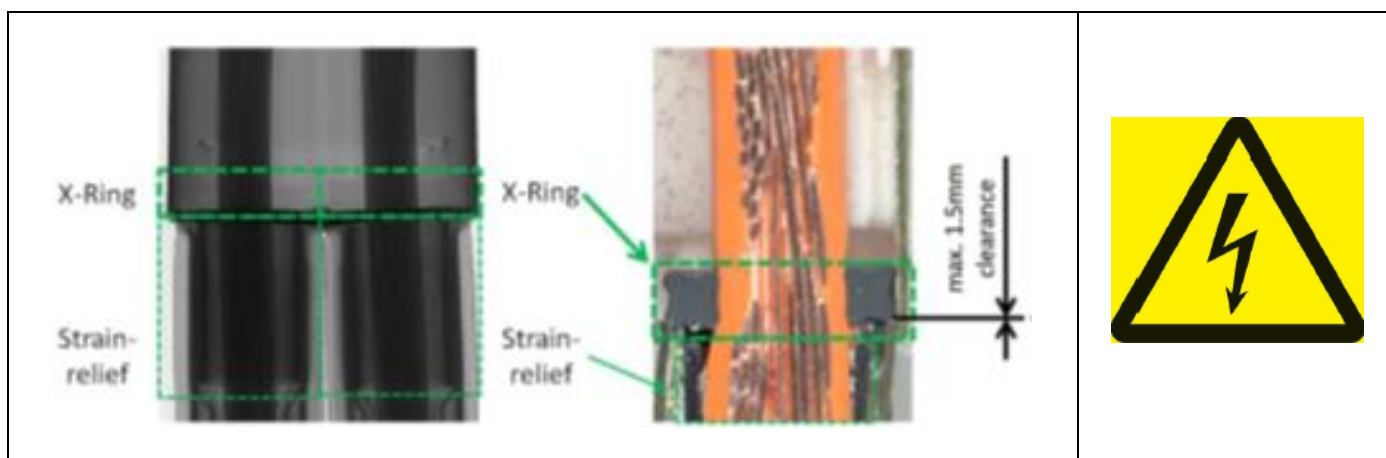



4.9 Crimp the shielding sleeve

In this process step, the shielding sleeve is crimped onto the cables and onto the contact carrier, as shown in **“Figure 4.26”**.

Figure 4.26: Representation 6.0 mm² SCC crimp the shielding sleeve (4.9 Crimp the shielding sleeve)



The cable shielding crimping (shielding sleeve, shield braid, stress relief, and cable) as well as the contact carrier crimping (shielding sleeve and contact carrier) are performed simultaneously, as shown in **“Figure 4.27”**.

Figure 4.27: Representation 6.0 mm² SCC shielding crimping and contact carrier crimping (4.9 Crimp the shielding sleeve)

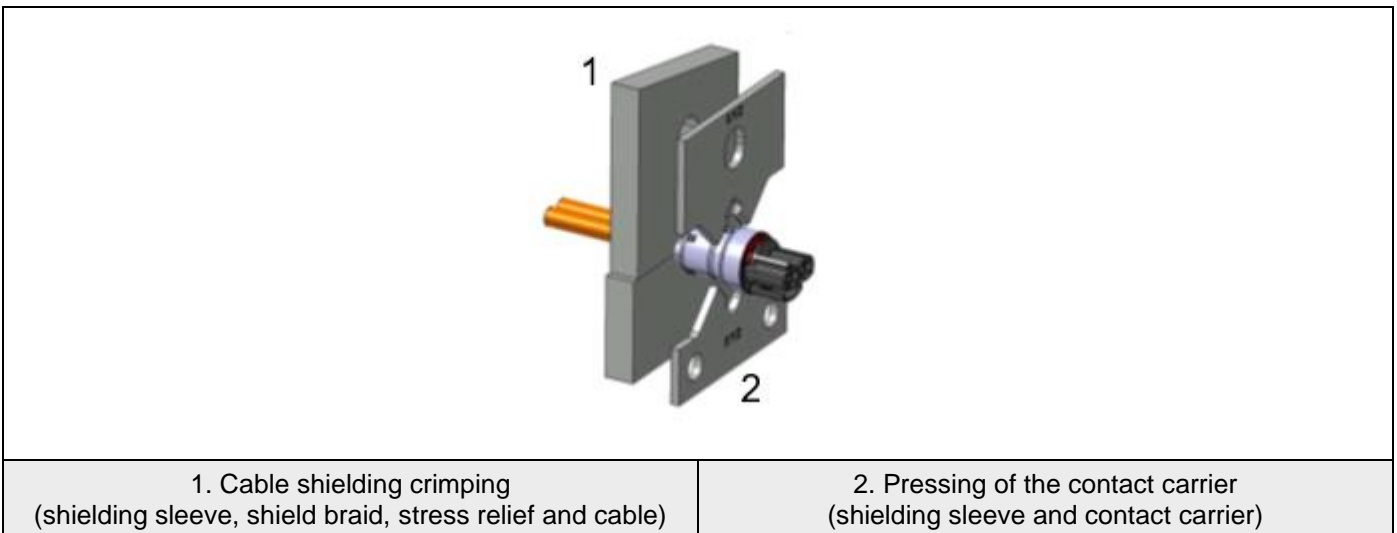

1. Cable shielding crimping
(shielding sleeve, shield braid, stress relief and cable)

2. Pressing of the contact carrier
(shielding sleeve and contact carrier)



The contact carrier must be oriented correctly to the crimping tool. The dimension specified in “**Table 4.7**” must be adhered to before and after crimping.

Figure 4.28: Representation 6.0 mm² SCC dimension D22 (4.9 Crimp the shielding sleeve)

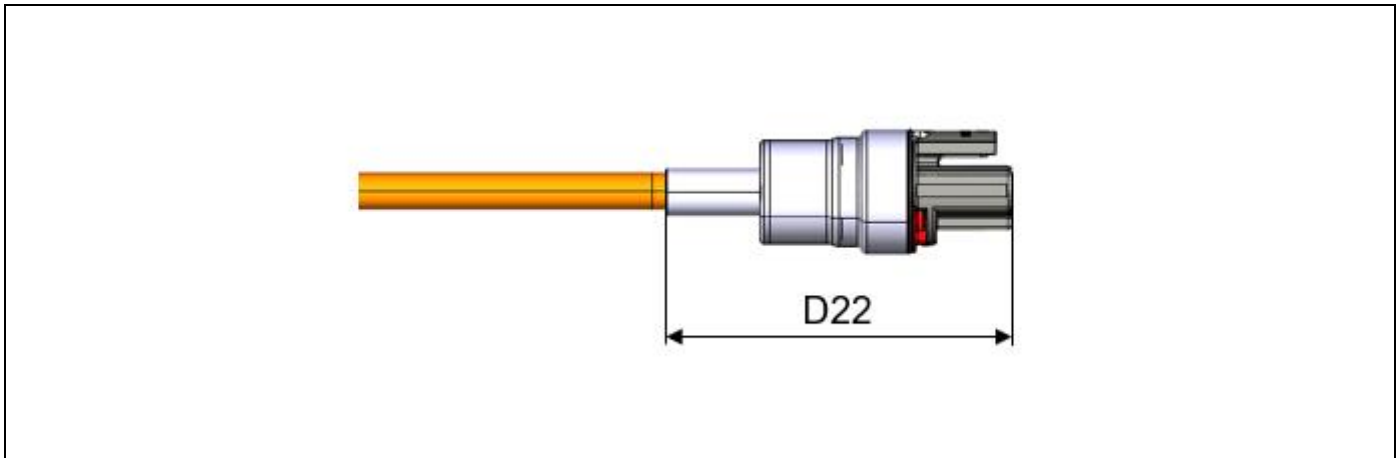

Table 4.7: Overview 6.0 mm² SCC dimension D22 (4.9 Crimp the shielding sleeve)

Dimension D22
53.2 ± 0.25 mm

The dimension D22 result from dimensions D16, D18, D19, and EVS-100068.

4.9.1 Cable shielding crimping using two half-shells

This chapter describes the position of the crimping tool, the geometries of the plunger and anvil, resulting crimp dimensions, and pull-off forces. The position of the plunger and anvil refers to the front face of the contact carrier, as shown in “**Figure 4.29**”. The dimension D23, which is listed in “**Table 4.8**”, indicates the position of the plunger and anvil.

Figure 4.29: Representation 6.0 mm² SCC dimension D23 (4.9.1 Cable shielding crimping using two half-shells)

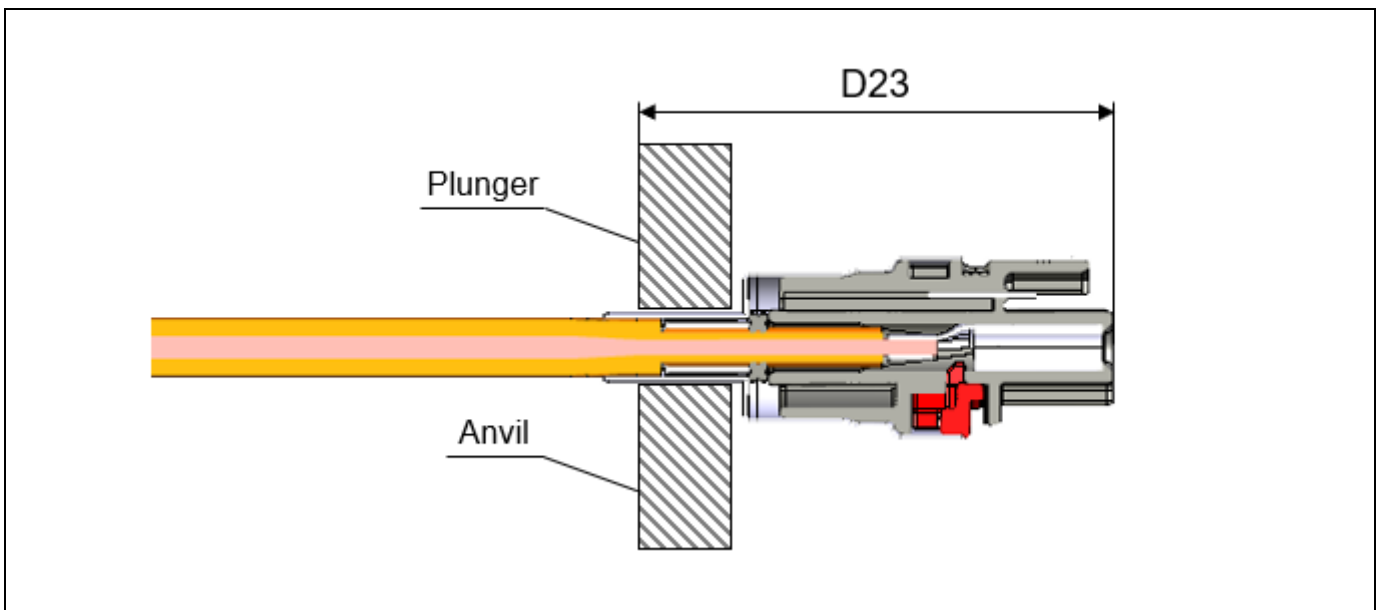
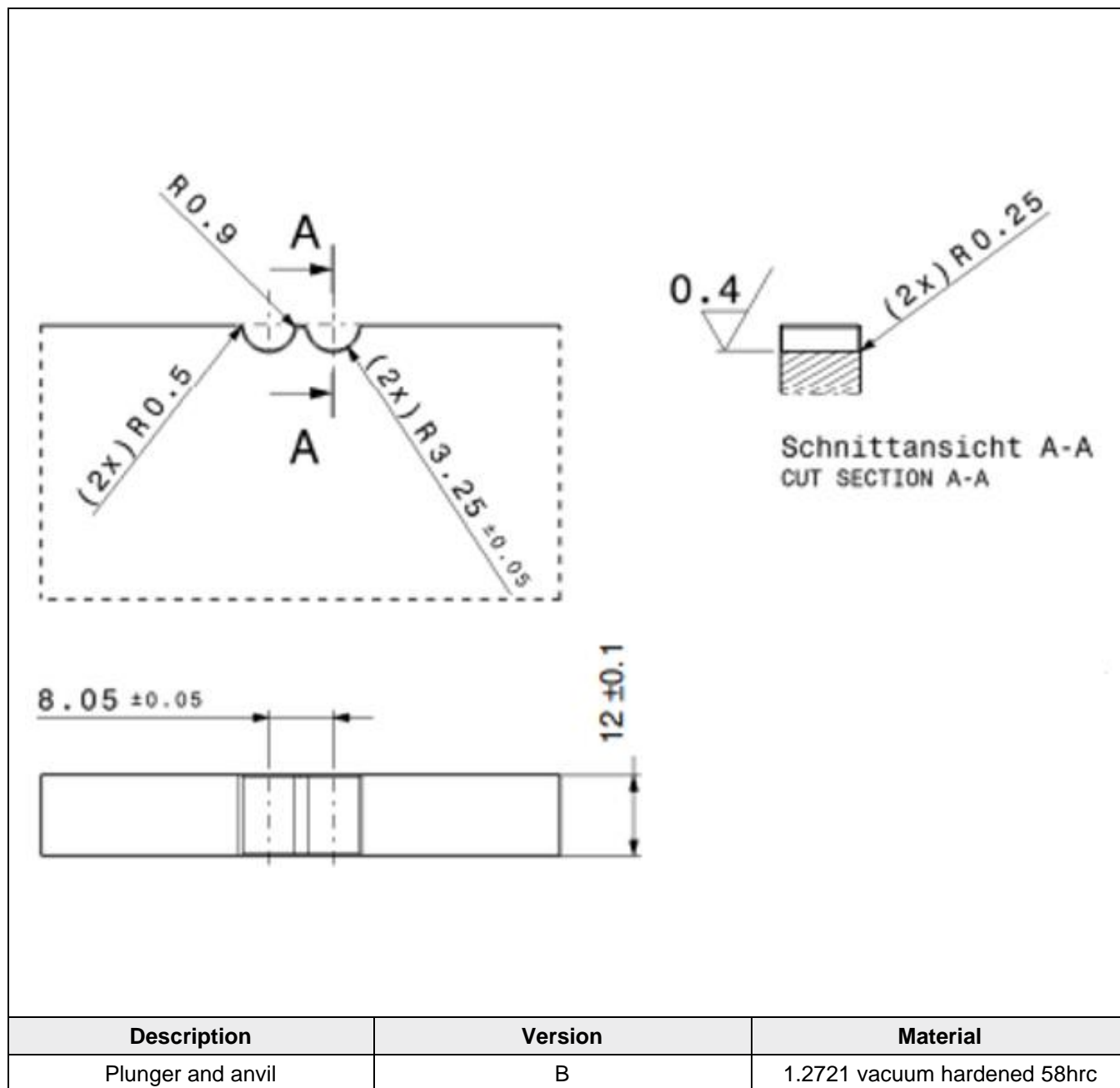

Table 4.8: Overview 6.0 mm² SCC dimension D23 (4.9.1 Cable shielding crimping using two half-shells)

Dimension D23
52.5 ± 0.1 mm

The plunger and anvil to be used is shown in “Figure 4.30”. In “Table 4.9”, the cables corresponding to the plunger and anvil are shown.

Figure 4.30: Representation 6.0 mm² SCC plunger and anvil Version B (4.9.1 Cable shielding crimping using two half-shells)



In “**Table 4.9**” dimension D24 and the cables are specified for the plunger and anvil version B, as shown in “**Figure 4.30**”.

Table 4.9: Overview 6.0 mm² SCC dimension D24, plunger and anvil Version B (4.9.1 Cable shielding crimping using two half-shells)

Cable manufacturer	Cable type	According Chapter 1.6	Cable cross section	Dimension D24
Coficab	FHLR91XCB91X T4 PSA	G	6.0 mm ²	6.8 ± 0.2 mm
Coroflex	FHLR2GCB2G 4.0 mm ² / 0.21 T180	H	6.0 mm ²	6.8 ± 0.2 mm
Gebauer & Griller	FHLR2GCB2G 1x4.0/T180 OR	N	6.0 mm ²	6.8 ± 0.2 mm
Kroschu	FHLR2GCB2G 4.00 QMM/0.21/T180	I	6.0 mm ²	6.8 ± 0.2 mm
Leoni	FHLR2GCB2G 4,0/0,31/T180	J	6.0 mm ²	6.8 ± 0.2 mm
Aptiv	FHLR91XC91X-C	P	6.0 mm ²	6.8 ± 0.2 mm

To check the dimension D24, the measurement must be carried out with a suitable measuring instrument, as shown in “**Figure 4.34**”. The width of the measuring instrument must be 3.5 ± 0.5 mm, as shown in “**Figure 4.31**”.

Figure 4.31: Representation 6.0 mm² SCC width of measuring instrument for dimension D24 (4.9.1 Cable shielding crimping using two half-shells)

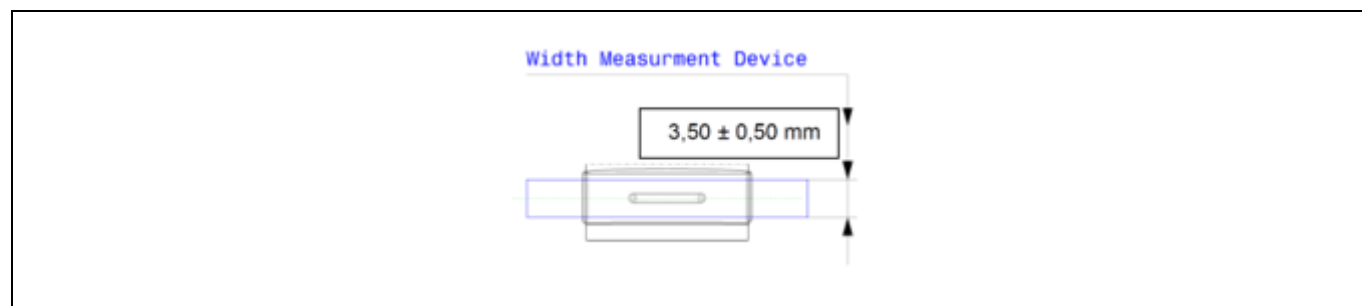



By crimping the shielding sleeve, a fold is created on both sides, as shown in “**Figure 4.32**”. The resulting dimension D25, as shown in “**Figure 4.34**”, is specified in “**Table 4.10**”. It must be ensured that the material of the shielding sleeve is not torn in the area of the fold.

Figure 4.32: Representation 6.0 mm² SCC dimension D25 (4.9.1 Cable shielding crimping using two half-shells)



Table 4.10: Overview 6.0 mm² SCC dimension D25 (4.9.1 Cable shielding crimping using two half-shells)

Cable cross section	Dimension D25
6.0 mm ²	max. 17.2 mm

To check dimension D25, as shown in “**Figure 4.34**”, a gauge with a maximum inside diameter of 17.2 mm must be used. The measurement must be taken across the entire area depicted in “**Figure 4.33**”.

Figure 4.33: Representation 6.0 mm² SCC measurement area dimension D25 (4.9.1 Cable shielding crimping using two half-shells)

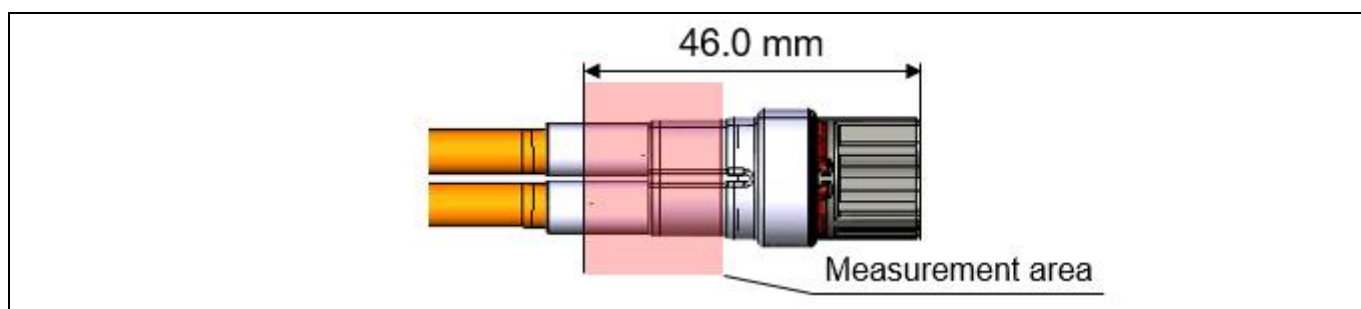
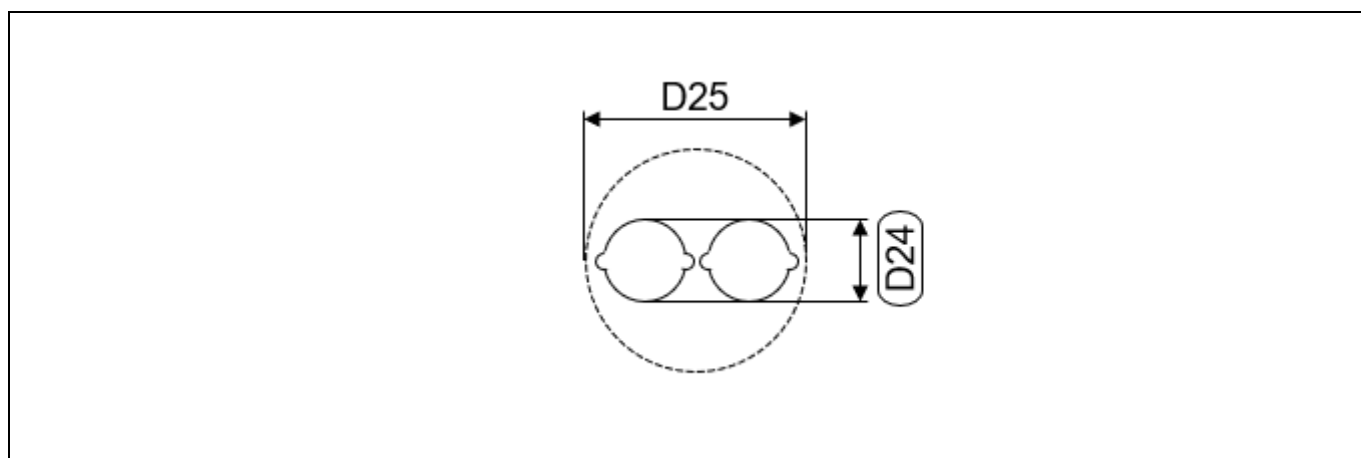
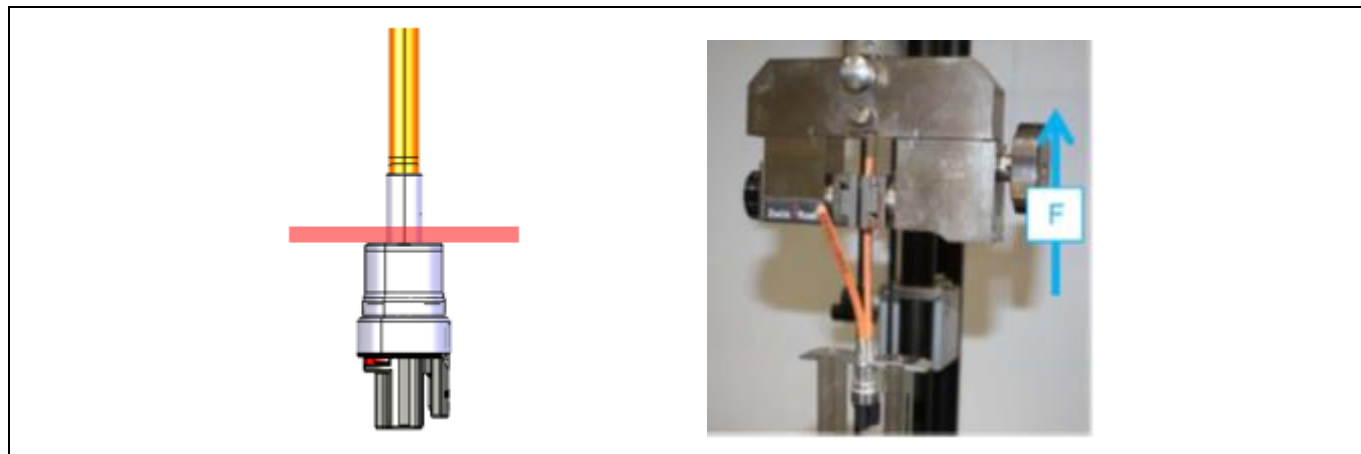

Figure 4.34: Representation 6.0 mm² SCC dimension D24 and D25 (4.9.1 Cable shielding crimping using two half-shells)



To measure the pull-off force, the cable must be securely clamped in a tensioning device. The distance between the clamping position of the cable and the fixing tape should be approximately 70.0 mm. The connector must be gripped on the shielding sleeve in the area shown in “**Figure 4.35**”. The testing must be conducted with an individual cable, as shown in “**Figure 4.35**”.

Figure 4.35: Representation 6.0 mm² SCC pull-off force clamping position shielding sleeve (4.9.1 Cable shielding crimping using two half-shells)



To ensure a correct inspection of the cable shielding compression, no HCT4 female terminals should be installed in the test specimens, as this would distort the measurement results. Further options for constructing the test specimens are shown in **Chapter “7.4 Sample preparation for shielding retention force”**. The required pull-off forces are shown in “**Table 4.11**”. The pull-off force is a special **(L2)** characteristic according to the **Chapter “1.7 Characteristics and customer approvals”**.

Table 4.11: Overview 6.0 mm² SCC pull-off force shielding sleeve (4.9.1 Cable shielding crimping using two half-shells)

Cable manufacturer	Cable type	According Chapter 1.6	Cable cross section	Pull-off force
Coficab	FHLR91XCB91X T4 PSA	G	6.0 mm ²	≥ 150.0 N
Coroflex	FHLR2GCB2G 4.0 mm ² / 0.21 T180	H	6.0 mm ²	≥ 150.0 N
Gebauer & Griller	FHLR2GCB2G 1x4.0/T180 OR	N	6.0 mm ²	≥ 150.0 N
Kroschu	FHLR2GCB2G 4.00 QMM/0.21/T180	I	6.0 mm ²	≥ 150.0 N
Leoni	FHLR2GCB2G 4,0/0,31/T180	J	6.0 mm ²	≥ 150.0 N
Aptiv	FHLR91XC91X-C	P	6.0 mm ²	≥ 150.0 N

4.9.2 Crimp the contact carrier

This chapter describes the position of the crimping tool, the geometries of the plunger and anvil, and the resulting crimp dimensions of the contact carrier crimping. The position of the plunger and anvil refers to the front surface of the contact carrier, as shown in “**Figure 4.36**”. The dimension D26, as listed in “**Table 4.12**”, indicates the position of the plunger and anvil. The four embossing positions (a-d) must be aligned towards the contact carrier. For this, the contact carrier must be secured against rotation. The green areas, as shown in “**Figure 4.36**”, can be used as a holder for the contact carrier. The embossing must be performed simultaneously.

Figure 4.36: Representation 6.0 mm² SCC dimension D26 and embossing positions a-d (4.9.2 Crimp the contact carrier)

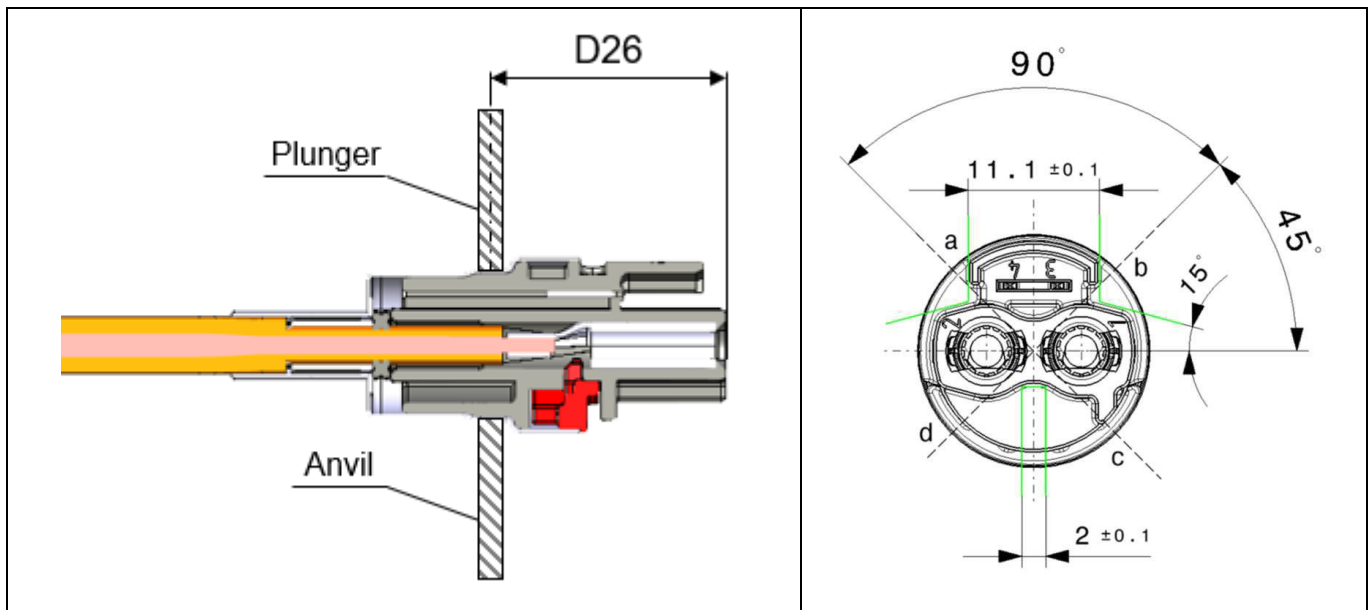

Table 4.12: Overview 6.0 mm² SCC dimension D26 (4.9.2 Crimp the contact carrier)

Dimension D26
25.3 ± 0.1 mm



The exact geometry of the plunger and anvil is shown in “Figure 4.37”.

Figure 4.37: Representation 6.0 mm² SCC plunger and anvil (4.9.2 Crimp the contact carrier)

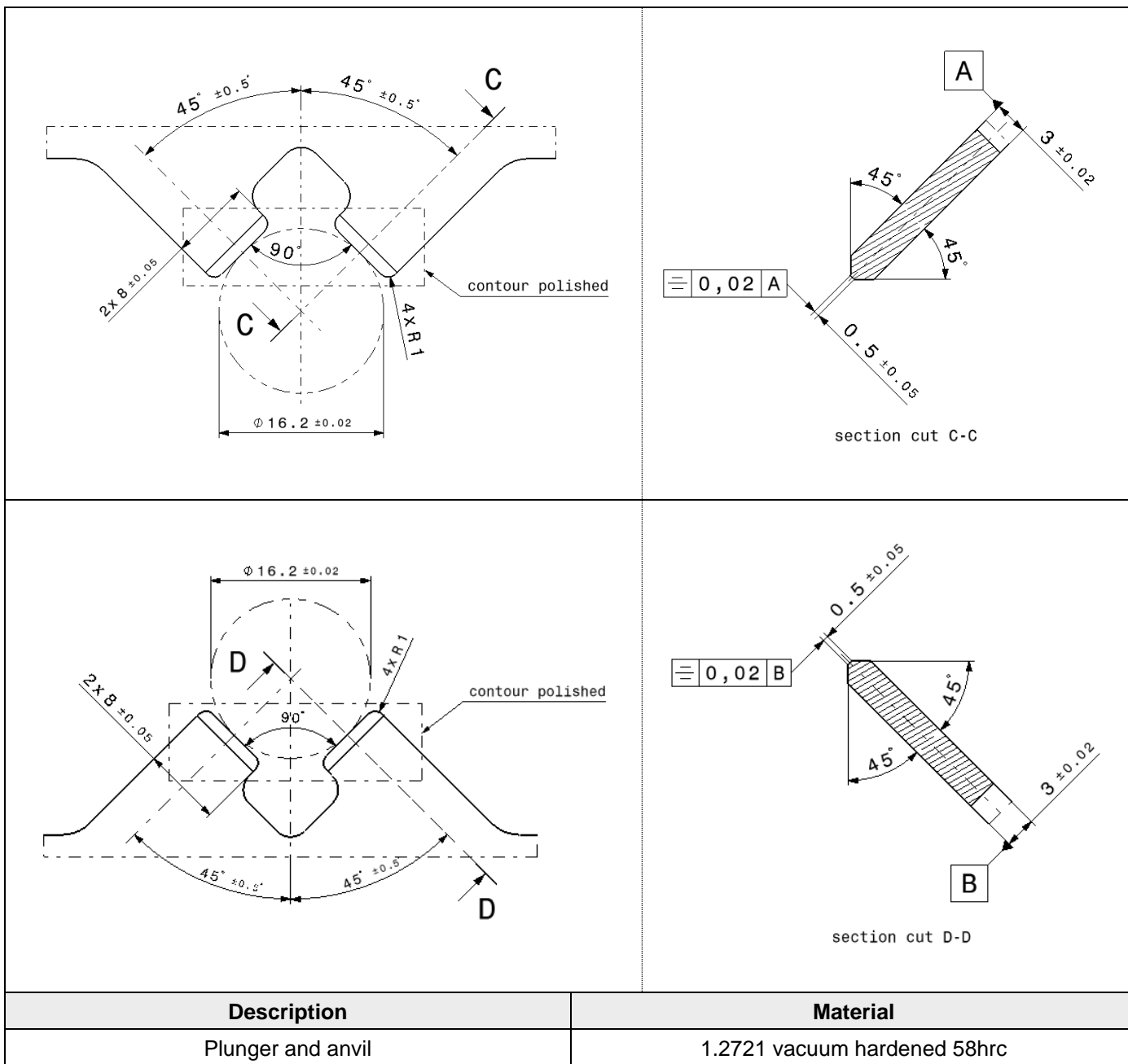

The dimension D27, which is listed in “**Table 4.13**”, results from the embossing between plunger and anvil, or a-c and b-d. To check the dimension D27, as shown in “**Figure 4.38**”, measurement must be taken in the embossing grooves. The measurement must be carried out with a suitable measuring instrument, and the measuring pickup must be < 0.6 mm in order for the measurement to be conducted.

Figure 4.38: Representation 6.0 mm² SCC dimension D27 (4.9.2 Crimp the contact carrier)

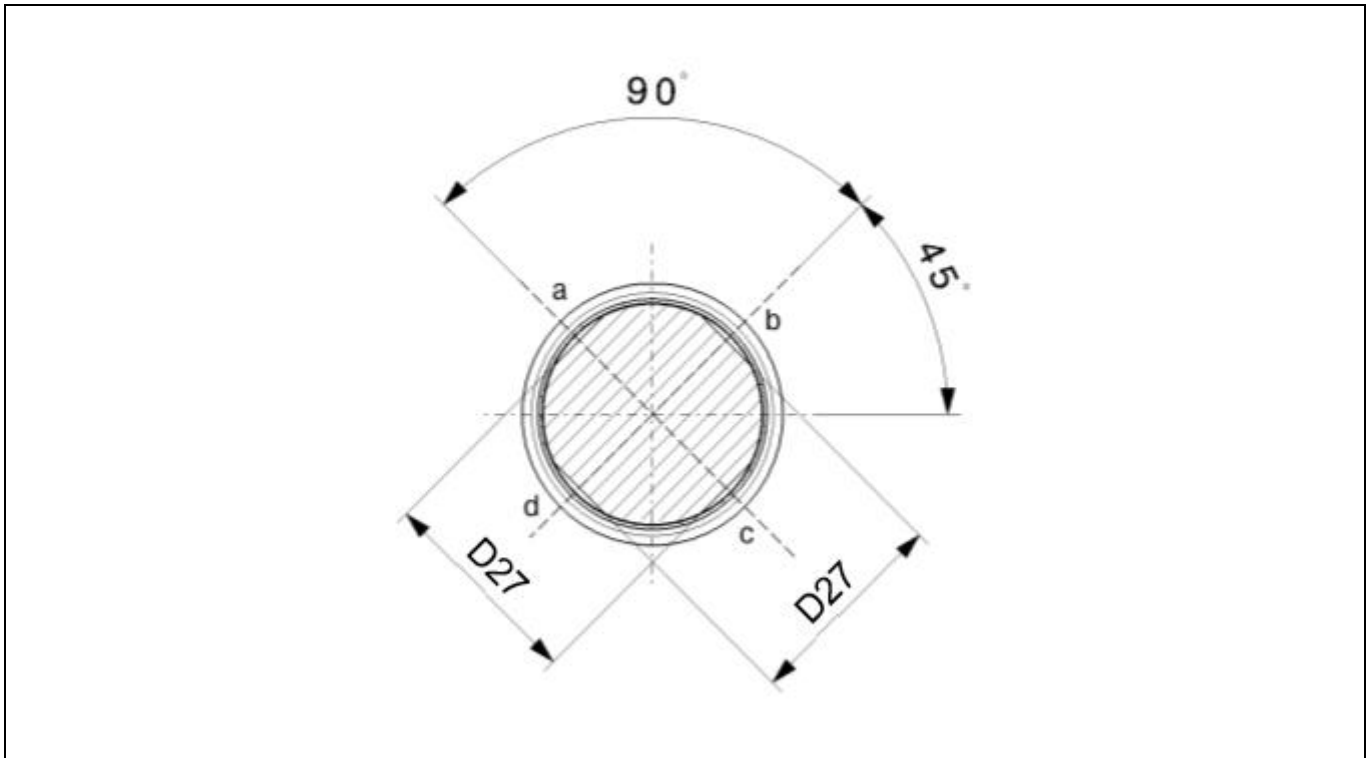

Table 4.13: Overview 6.0 mm² SCC dimension D27 (4.9.2 Crimp the contact carrier)

Dimension D27
16.4 ± 0.1 mm

5 Completion steps 4.0 mm² & 6.0 mm² SCC

In this chapter, the completion steps related to the preceding process steps from **Chapter “3 Processing steps 4.0 mm² SCC”** and **Chapter “4 Processing steps 6.0 mm² SCC”** for the HPS40-2 2+2 female connector SCC 4.0 mm² and HPS40-2 2+2 female connector SCC 6.0 mm² are described in detail. The example images depict the necessary components for the 6.0 mm² variant.

5.1 Assemble the locking sleeve

In this process step, the locking sleeve is mounted onto the previously prepared cable assembly, as shown in **“Figure 5.1”**.

Figure 5.1: Representation 4.0 mm² & 6.0 mm² SCC assembling the locking sleeve (5.1 Assembling the locking sleeve)



The cable assembly must be mounted in the correct orientation to the locking sleeve, as shown in **“Figure 5.2”**. Both polarizations of the locking sleeve must be symmetric to the axis between the center of Pin 1 and Pin 2 of the contact carrier. Additionally, the polarization of the locking sleeve must be positioned on the side of Pin 1 of the contact carrier.

Figure 5.2: Representation 4.0 mm² & 6.0 mm² SCC orientation contact carrier in locking sleeve (5.1 Assembling the locking sleeve)

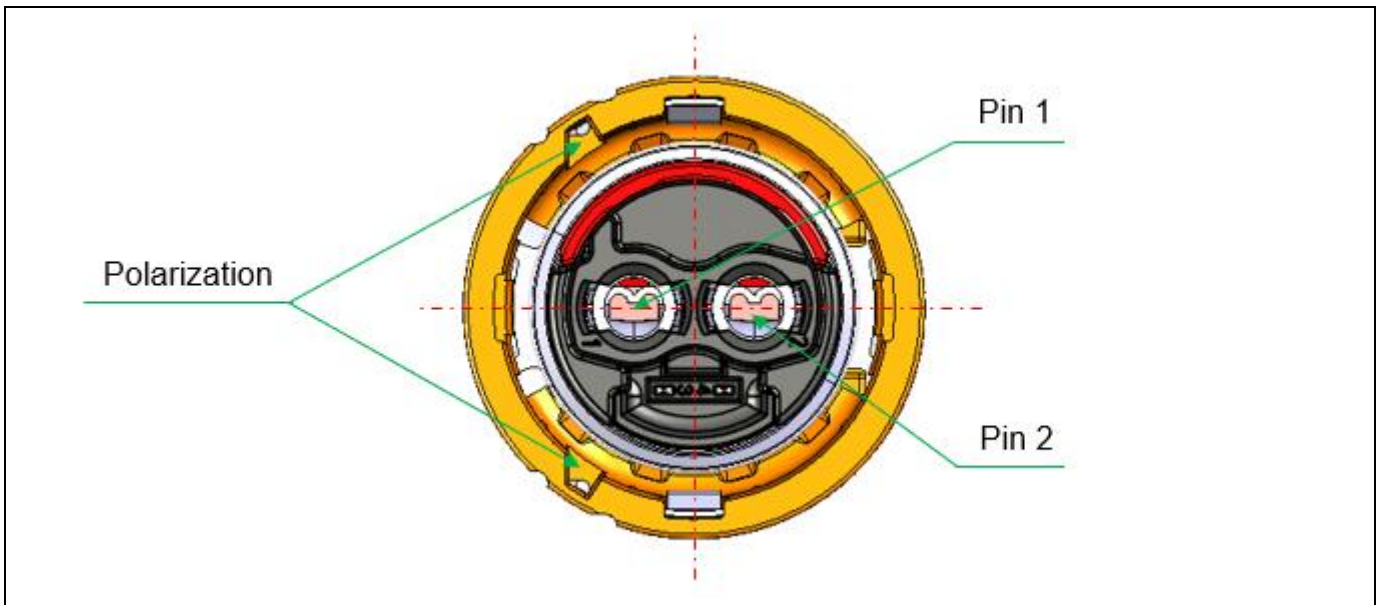



The locking sleeve must be power-assisted mounted onto the cable assembly until dimension D28 is reached, as listed in “Table 5.1”. Dimension D29 serves solely for verification purposes and is also listed in “Table 5.1”.

Figure 5.3: Representation 4.0 mm² & 6.0 mm² SCC dimension D28 & D29 (5.1 Assembling the locking sleeve)

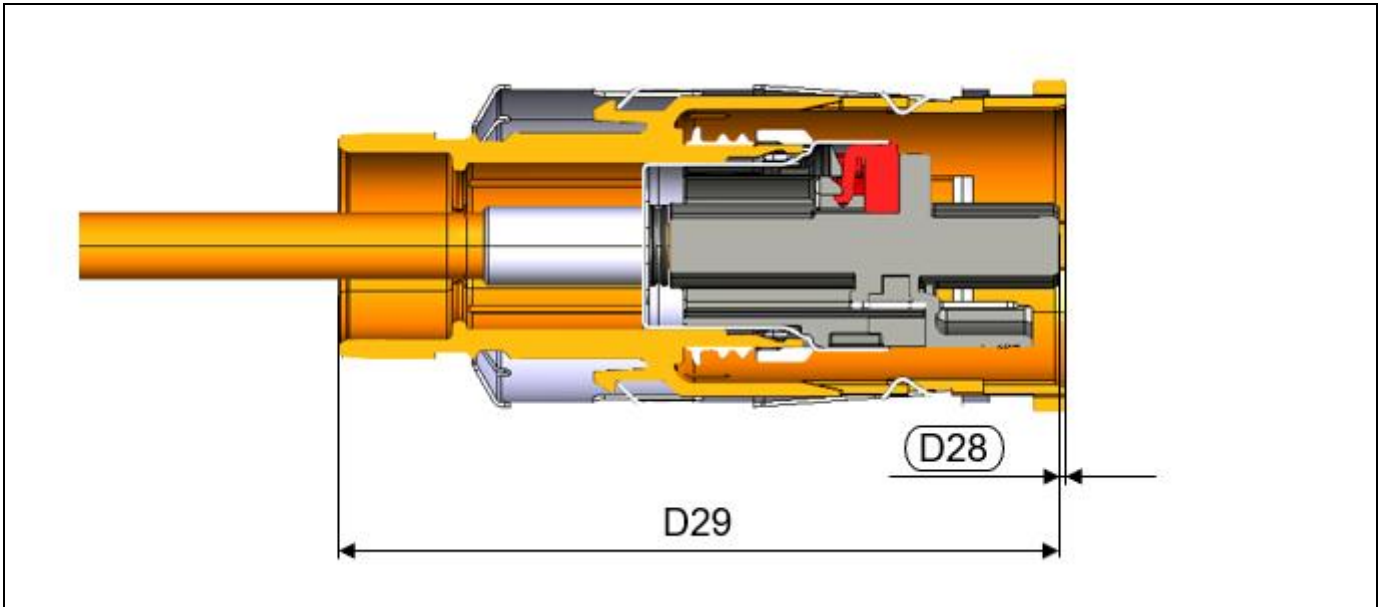
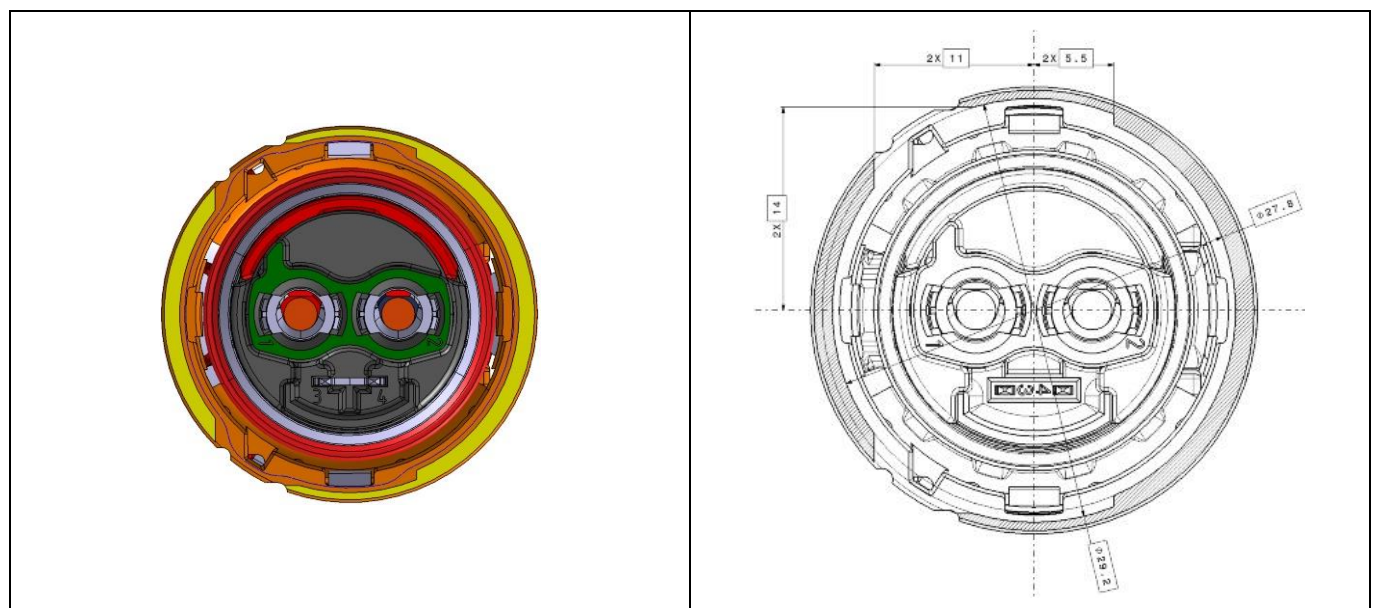

Table 5.1: Overview 4.0 mm² & 6.0 mm² SCC dimension D28 & D29 (5.1 Assembling the locking sleeve)

Dimension D28	Dimension D29
0.7 ± 0.1 mm	66.7 mm

The reference points for dimension D28 are in the middle of the contact carrier between Pin 1 and Pin 2, as well as on the end face of the locking sleeve, as shown in “Figure 5.4”. Any parting lines on the end face of the locking sleeve are considered and do not affect the required insertion depth.

Figure 5.4: Representation 4.0 mm² & 6.0 mm² SCC reference points contact carrier & locking sleeve (5.1 Assembling the locking sleeve)





The retaining ring in the locking sleeve must not exceed the dimension $D\emptyset1$, which is listed in “**Table 5.2**”.

Figure 5.5: Representation 4.0 mm² & 6.0 mm² SCC dimension $D\emptyset1$ (5.1 Assembling the locking sleeve)

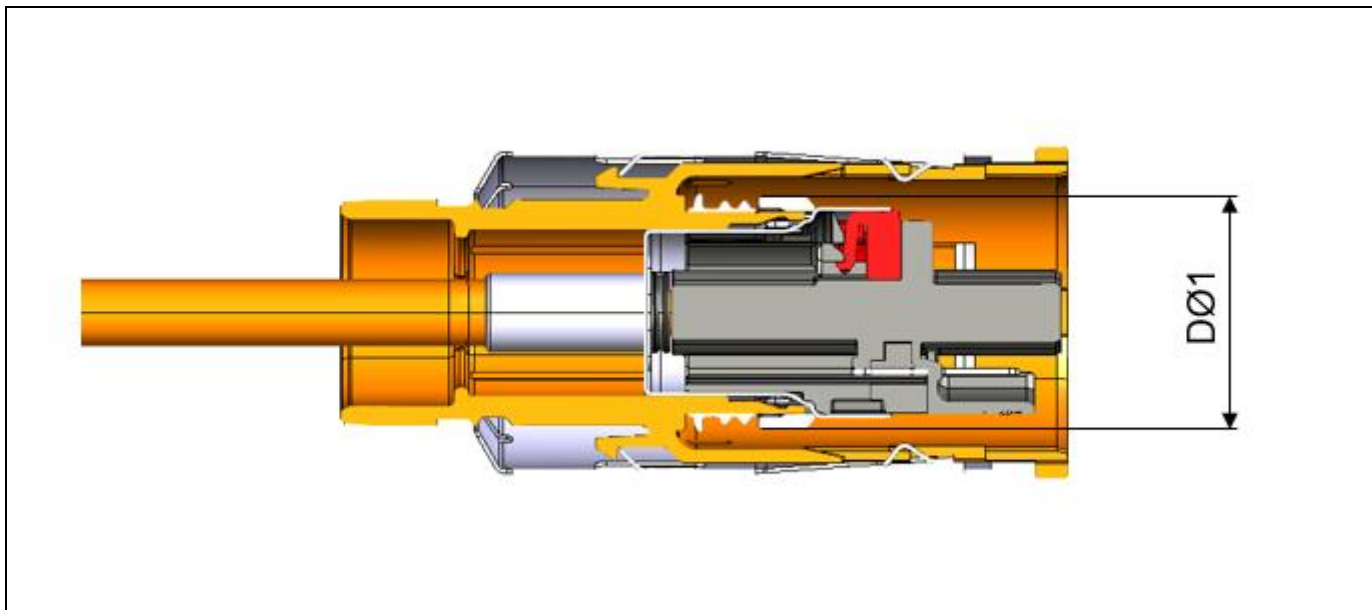

Table 5.2: Overview 4.0 mm² & 6.0 mm² SCC dimension $D\emptyset1$ (5.1 Assembling the locking sleeve)

Dimension $D\emptyset1$
max. 21.7 mm

5.2 Assemble the cable seal and cover cap

In this process step, the cable seal and the cover cap are assembled into the locking sleeve, as shown in **“Figure 5.6”**.

Figure 5.6: Representation 4.0 mm² & 6.0 mm² SCC assemble the cable seal and cover cap into locking sleeve (5.2 Assemble the cable seal and cover cap)

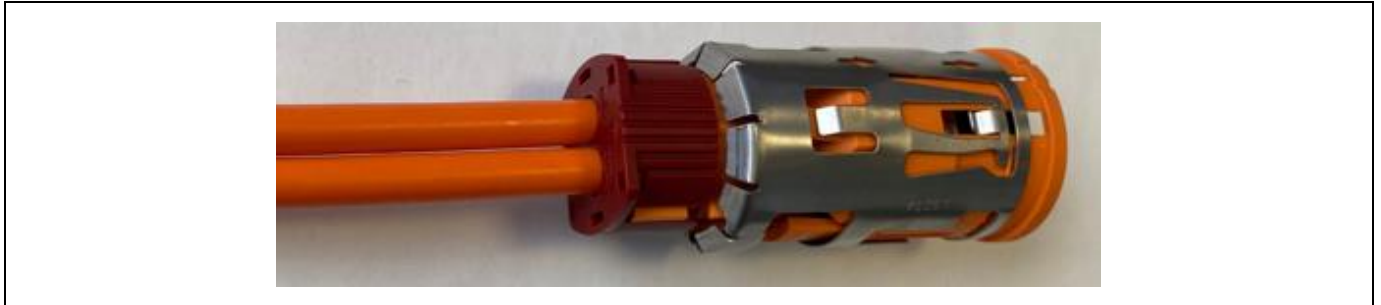

The cable seal may be slightly expanded during assembly. It is possible to shift the cable seal along with the cover cap on the cable; however, care must be taken to ensure that the seal is not twisted or trapped.

Figure 5.7: Representation 4.0 mm² & 6.0 mm² SCC assemble the cable seal into locking sleeve (5.2 Assemble the cable seal and cover cap)

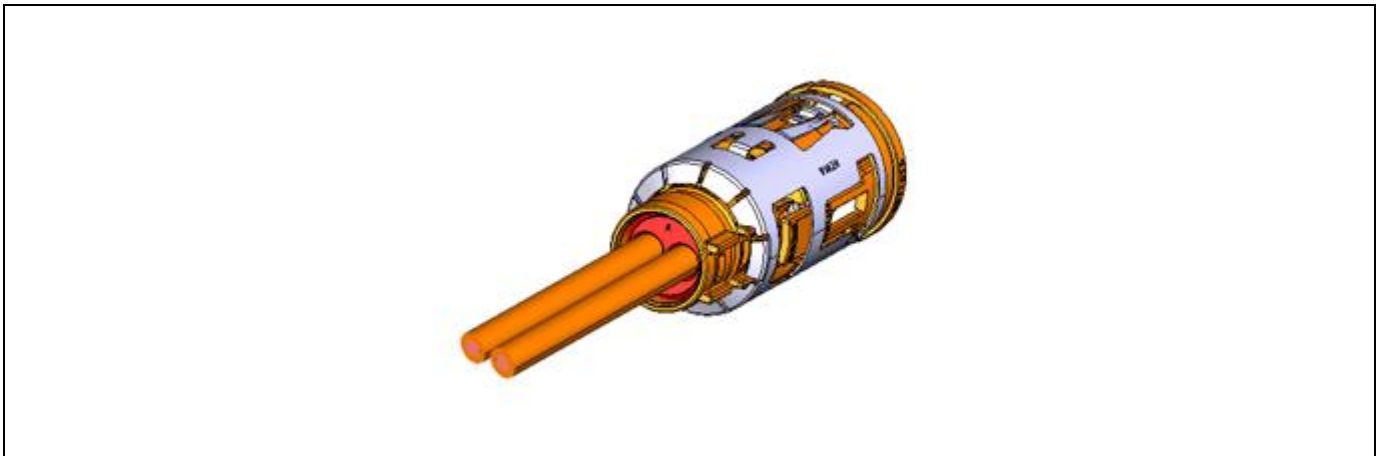

The seal is self-lubricating or oil-exuding. The final inspection to ensure that the seal has been properly installed without damage, as well as the use of additional lubricant, must be coordinated with the respective OEM.



The locking hook of the cover cap must be mounted into the recess of the locking sleeve. The cover cap has reached the end position when both locking hooks snap in and lie straight on both sides to the locking sleeve, as shown in “**Figure 5.8**”. This means that the locking hooks must not remain in a bent position. Achieving the end position of the cover cap ensures that the cable seal is in the correct position.

Figure 5.8: Representation 4.0 mm² & 6.0 mm² SCC assemble the cover cap into locking sleeve (5.2 Assemble the cable seal and cover cap)

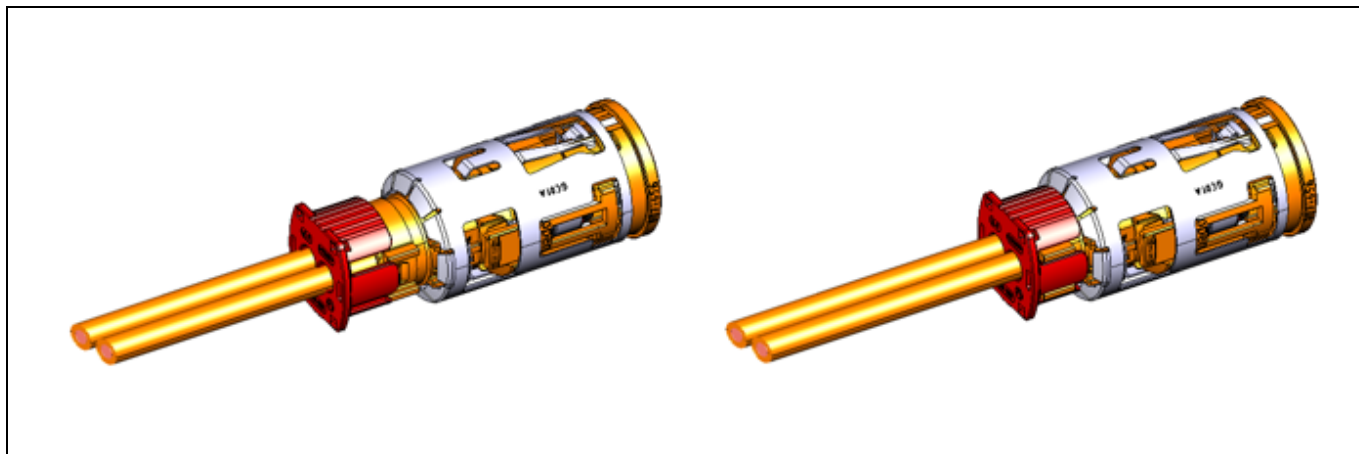

The dimension D30, as listed in “**Table 5.3**”, is used to check the achievement of the final position of the cover cap.

Figure 5.9: Representation 4.0 mm² & 6.0 mm² SCC dimension D30 (5.2 Assemble the cable seal and cover cap)

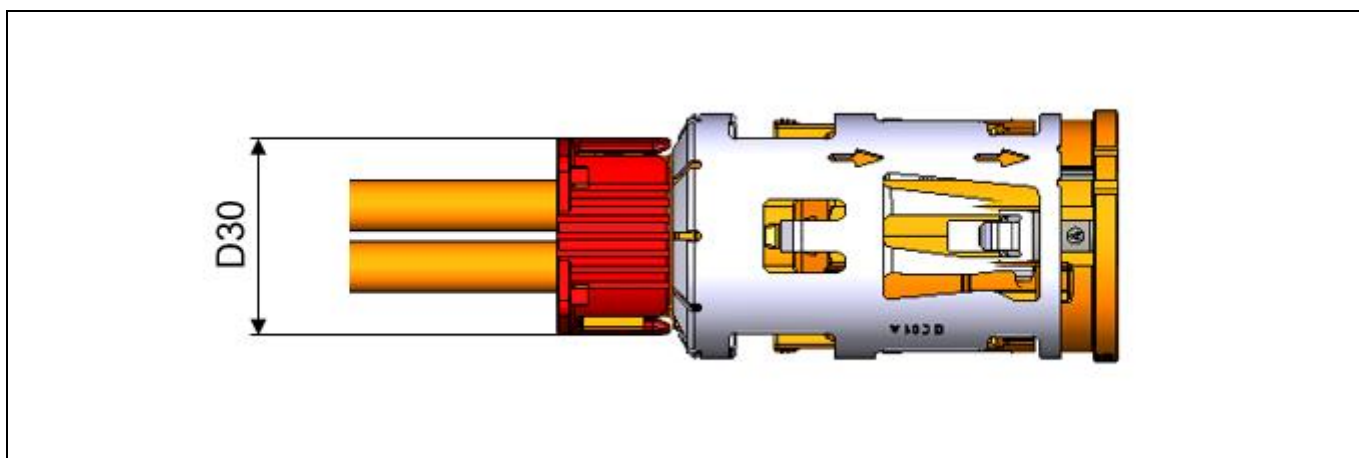

Table 5.3: Overview 4.0 mm² & 6.0 mm² SCC dimension D30 (5.2 Assemble the cable seal and cover cap)

Dimension D30
max. 25.0 mm

If the 90° angled cap is used according to **Chapter “6.2 Assemble the 90° angled cap”**, the use of the cover cap and thus the assembly process steps for it are omitted.



6 Completion steps 4.0 mm² & 6.0 mm² SCC (optional parts)

In this chapter, the completion steps for the optional parts related to the preceding process steps from **Chapter “3 Processing steps 4.0 mm² SCC”**, **Chapter “4 Processing steps 6.0 mm² SCC”** and **Chapter “5 Completion steps 4.0 mm² & 6.0 mm² SCC”** for the HPS40-2 2+2 female connector SCC 4.0 mm² and HPS40-2 2+2 female connector SCC 6.0 mm² are described in detail. The example images depict the necessary components for the 6.0 mm² variant.

6.1 Assemble the In-Line CPA cover

In this process step, the In-Line CPA housing is mounted onto the locking sleeve, as shown in **“Figure 6.1”**.

Figure 6.1: Representation 4.0 mm² & 6.0 mm² SCC assemble the In-Line CPA cover onto locking sleeve (6.1 Assemble the In-Line CPA cover)





The In-Line CPA cover must be power-assisted and position-oriented mounted on the locking sleeve. The end position of the In-Line CPA cover is reached when both locking hooks are snapped in and align straight on both sides to the locking sleeve, as shown in “**Figure 6.2**”. This means that the locking hooks must not remain in a bent position. For control, the dimension D31, listed in “**Table 6.1**”, can also be used. Under certain circumstances (tolerances), it may be necessary to manually apply pressure to the locking hooks.

Figure 6.2: Representation 4.0 mm² & 6.0 mm² SCC dimension D31 (6.1 Assemble the In-Line CPA cover)

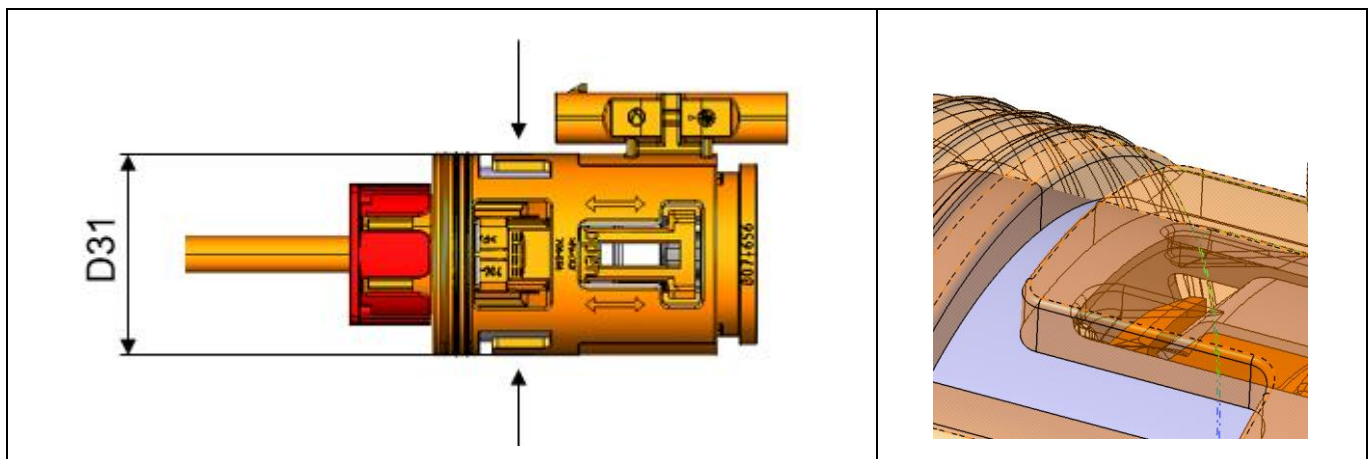

Table 6.1: Overview 4.0 mm² & 6.0 mm² SCC dimension D31 (6.1 Assemble the In-Line CPA cover)

Dimension D31
max. 35.0 mm

Each processor has the freedom to carry out this step at an earlier stage in production. Suitable measures must be considered for handling the component and the impact on the equipment of the previous work steps.



6.2 Assemble the 90° angled cap

In this process step, the 90° angled cap is mounted onto the locking sleeve, as shown in “**Figure 6.3**”.

Figure 6.3: Representation 4.0 mm² & 6.0 mm² SCC assemble the 90° angled cap onto locking sleeve (6.2 Assemble the 90° angled cap)

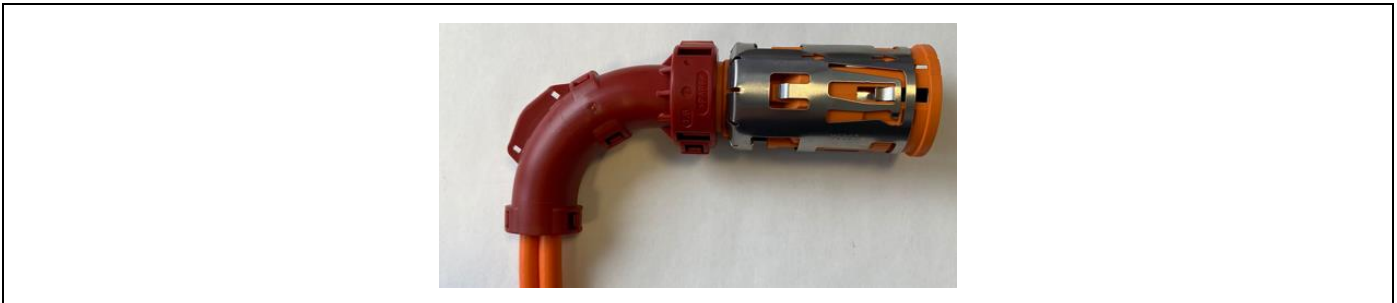

To facilitate the assembly of the 90° angled cap, the cable must be bent at a 90° angle and inserted into the first half-shell of the 90° angled cap, as shown in “**Figure 6.4**”. When closing the 90° angled cap, ensure that the insulation of the cable is not pinched. Additionally, only the cable is allowed to be inserted into the 90° angled cap. This means that no additional components such as tape, protective tubing, or similar are permitted in the 90° angled cap. All five locking hooks must be engaged. After the assembly of the 90° angled cap, it is no longer possible to change the exit angle.

Figure 6.4: Representation 4.0 mm² & 6.0 mm² SCC assemble and close the 90° angled cap onto locking sleeve (6.2 Assemble the 90° angled cap)

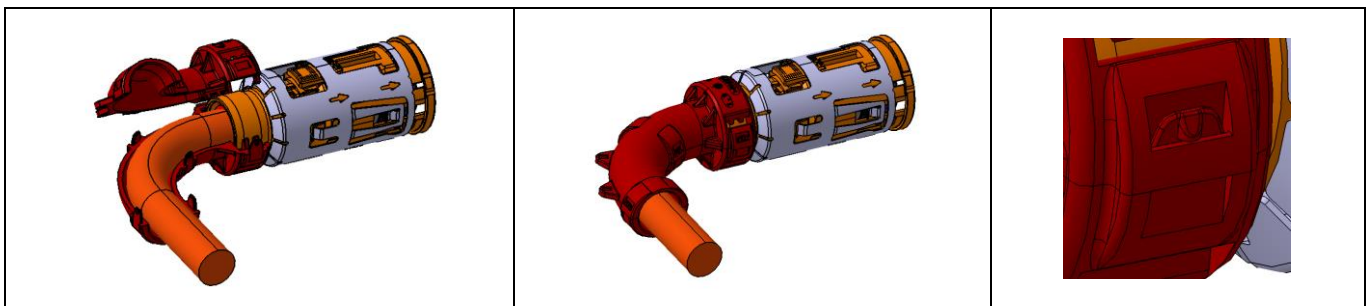



The orientation of the cable is fixed by the polarization geometry of the locking sleeve. The 90° angled cap can be assembled in 45° steps, as shown in “Figure 6.5”. The polarization geometry should be placed on one side of the half-shell of the 90° angled cap to obtain pre-orientation (left illustration in “Figure 6.5”). It is possible to place the connector into the angled cap without pre-orientation (right illustration in “Figure 6.5”), but it should be noted that, during closing the 90° angled cap, the polarization geometry finds the correct position. The position of -90° can only be placed on one side (left illustration in “Figure 6.5”) because, on the other side (right illustration in “Figure 6.5”), there would be a collision of the half-shells with the polarization geometry during the closing of the 90° angled cap.

Figure 6.5: Representation 4.0 mm² & 6.0 mm² SCC different orientations 90° angled cap (6.2 Assemble the 90° angled cap)

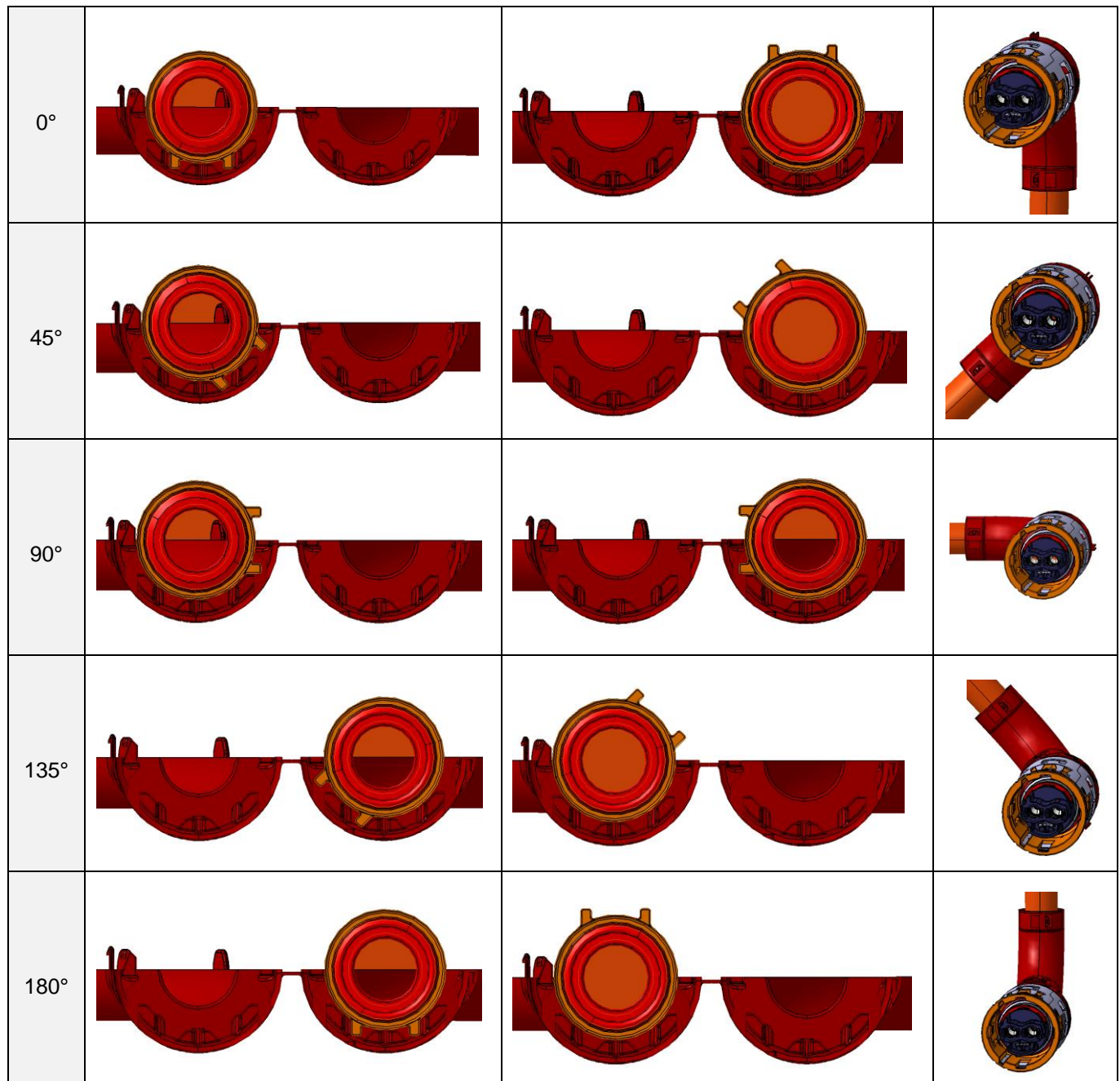



-135°			
-90°			
-45°			

6.3 Assemble the coding clip on the cover cap

In this process step, the coding clip is mounted onto the cover cap, as shown in “**Figure 6.6**”.

Figure 6.6: Representation 4.0 mm² & 6.0 mm² SCC assemble the coding clip onto cover cap (6.3 Assemble the coding clip on the cover cap)



Depending on customer requirements, a coding clip can be mounted onto the cover cap. For the HPS40-2 2+2 cover cap 4.0 mm² SCC non-polarized (706-822-503) and the HPS40-2 2+2 cover cap 6.0 mm² SCC non-polarized (706-822-505), the coding clip can be mounted in two positions, as shown in “**Figure 6.7**”. Therefore, the desired position must be determined in consultation with the customer.

Figure 6.7: Representation 4.0 mm² & 6.0 mm² SCC coding clip for 706-822-503 & 706-822-505 (6.3 Assemble the coding clip on the cover cap)

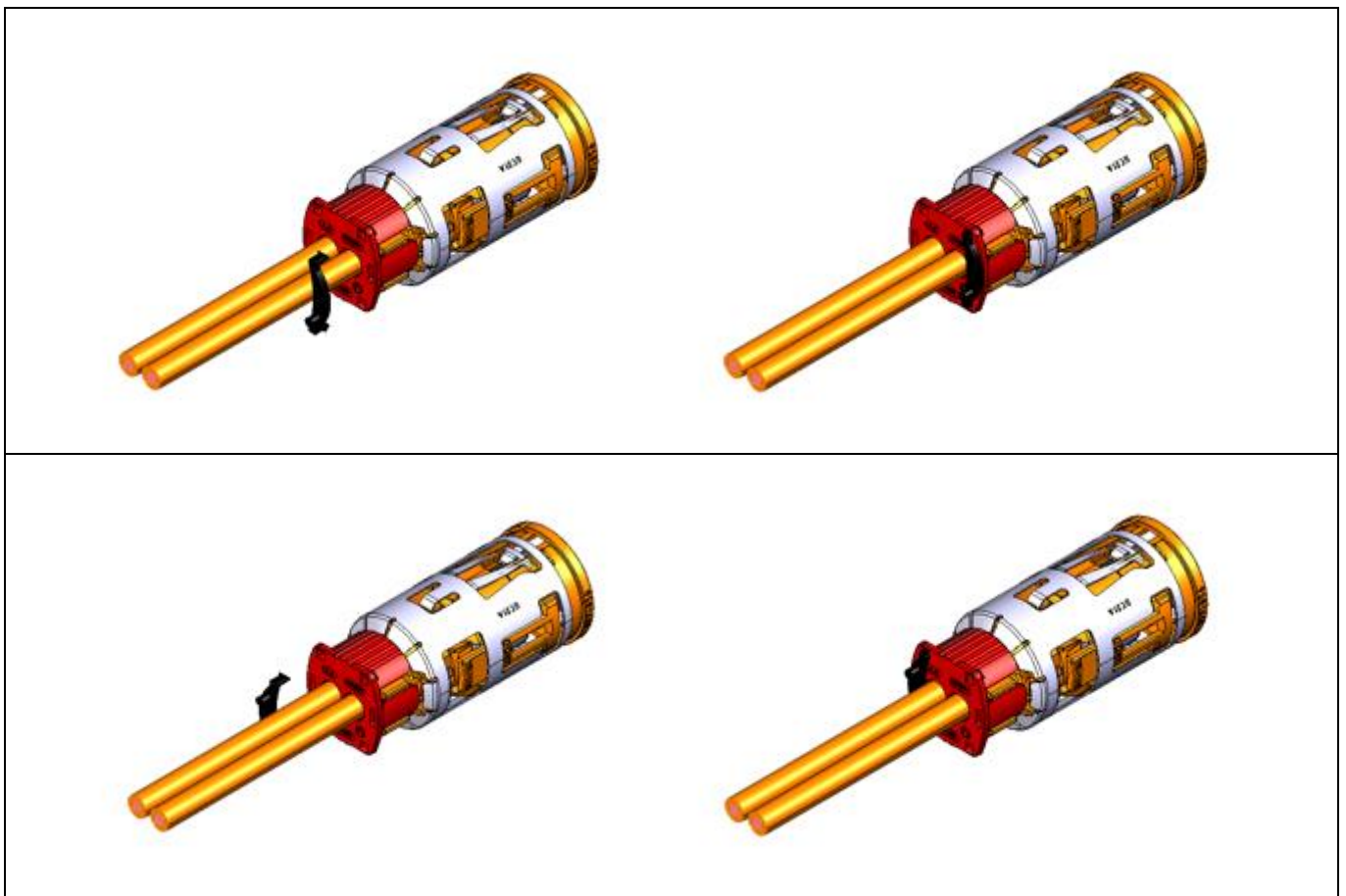



For the HPS40-2 2+2 cover cap 4.0 mm² SCC polarized (706-430-504) and the HPS40-2 2+2 cover cap 6.0 mm² SCC polarized (706-430-505), the coding clip can only be mounted in one position, as shown in **“Figure 6.8”**.

Figure 6.8: Representation 4.0 mm² & 6.0 mm² SCC coding clip for 706-430-504 & 706-430-505 (6.3 Assemble the coding clip on the cover cap)



The coding clip is the same color as the contact carrier and serves to simplify the identification of the connector coding. Therefore, it must be ensured that the coding or color of the coding clip matches the coding or color of the contact carrier. This can be visually checked by color or mechanically by comparing the dimensions, which differ under the various coding.



6.4 Assemble the coding clip on the 90° angled cap

In this process step, the coding clip is mounted onto the 90° angled cap, as shown in “**Figure 6.9**”.

Figure 6.9: Representation 4.0 mm² & 6.0 mm² SCC assemble the coding clip on the 90° angled cap (6.4 Assemble the coding clip on the 90° angled cap)

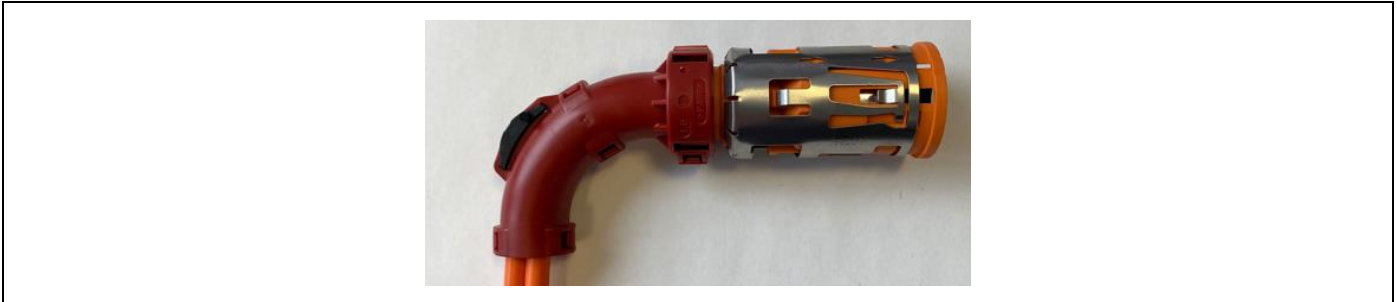

Depending on customer requirements, a coding clip can be mounted onto the 90° angled cap on both sides, as shown in “**Figure 6.10**”.

Figure 6.10: Representation 4.0 mm² & 6.0 mm² SCC coding clip for 90° angled cap (6.4 Assemble the coding clip on the 90° angled cap)

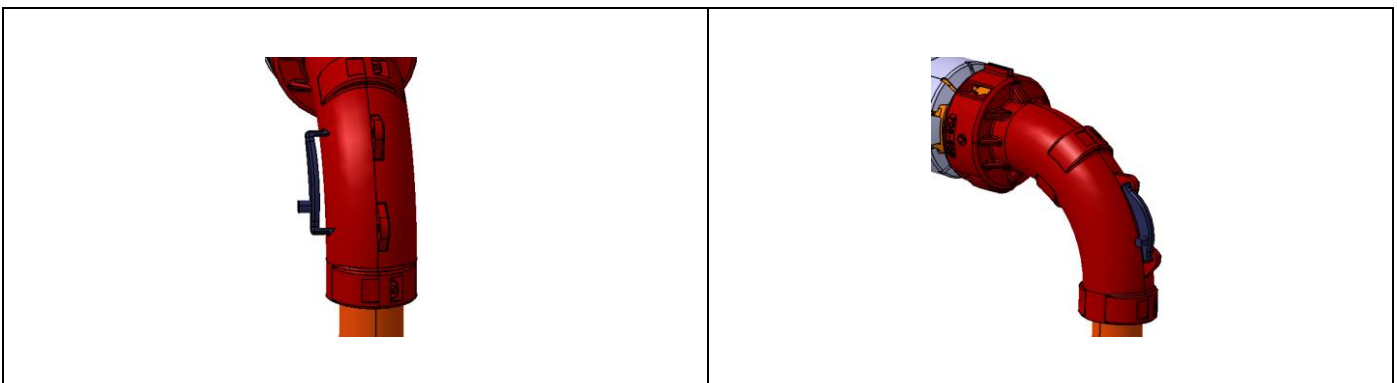

The coding clip is the same color as the contact carrier and serves to simplify the identification of the connector coding. Therefore, it must be ensured that the coding or color of the coding clip matches the coding or color of the contact carrier. This can be visually checked by color or mechanically by comparing the dimensions, which differ under the various coding.

6.5 Assemble the protection cap

In this process step, the protection cap is mounted onto the connector, as shown in “**Figure 6.11**”.

Figure 6.11: Representation 4.0 mm² & 6.0 mm² SCC assemble the transport protection cap (6.5 Assemble the transport protection cap)



Depending on customer requirements, a protection cap can be mounted onto the connector, as shown in “**Figure 6.12**”.

Figure 6.12: Representation 4.0 mm² & 6.0 mm² SCC assemble the transport protection cap onto the connector (6.5 Assemble the transport protection cap)

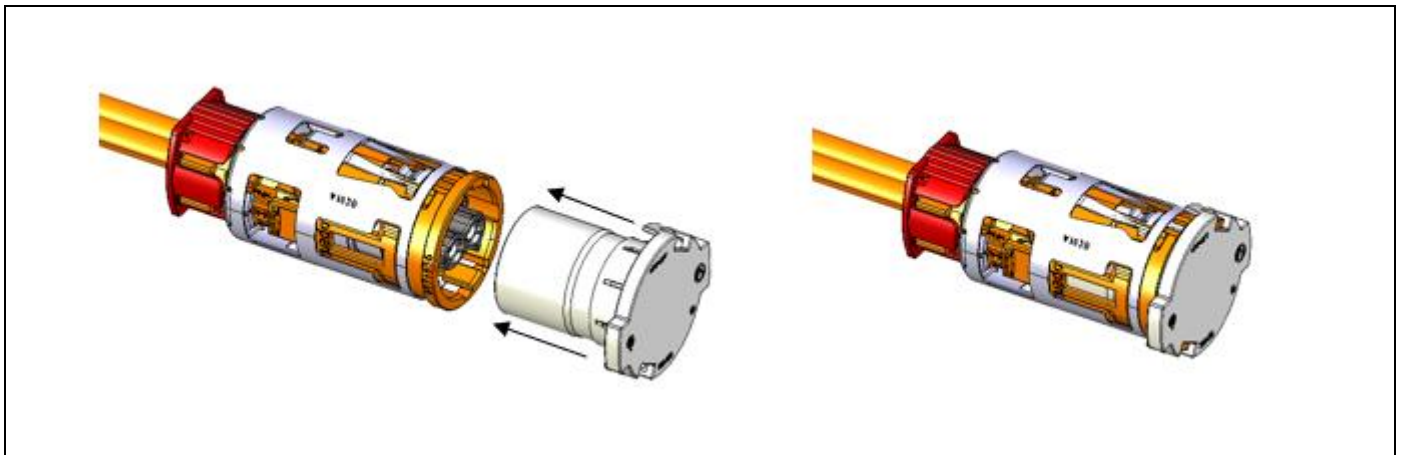

The protection cap must be inserted until both locking elements snap over the front collar of the locking sleeve. It is not necessary to pay attention to a specific orientation, as the protection cap can be rotated 360° during and after assembly.



7 Technical information

This chapter describes additional technical information related to the previous process steps from **Chapter “3 Processing steps 4.0 mm² SCC”**, **Chapter “4 Processing steps 6.0 mm² SCC”**, **Chapter “5 Completion steps 4.0 mm² & 6.0 mm² SCC”**, and **Chapter “6 Completion steps 4.0 mm² & 6.0 mm² SCC (optional parts)”** for the HPS40-2 2+2 female connector SCC 4.0 mm² and HPS40-2 2+2 female connector SCC 6.0 mm² in detail.

7.1 Storage of the finished wiring harness

For an orderly and controlled stacking of the harnesses to quantitatively free defined bundles.

7.2 Technical cleanliness

This chapter details the necessary technical cleanliness for the HPS40-2 2+2 female connector SCC 4.0 mm² and HPS40-2 2+2 female connector SCC 6.0 mm².

Generally, cleanliness must be maintained on and inside the HPS40-2 2+2 female connector SCC 4.0 mm² and HPS40-2 2+2 female connector SCC 6.0 mm².

Metallic particles that may be generated during the processing of the connector should be removed as much as possible through appropriate measures. No metallic particles larger than > 1,000 µm are permitted inside or on the connector.

Additionally, the components should be protected from further contamination during transport. Appropriate packaging must be provided. A possible transport protection cap is optionally available from Hirschmann Automotive GmbH.

If OEM-specific requirements are described, only these need to be considered for the respective OEM. Otherwise, the general requirements listed in **“Table 7.1”** apply.

7.2.1 Customer: Miscellaneous

Table 7.1: Overview 4.0 mm² & 6.0 mm² SCC technical cleanliness requirements for Customer: Miscellaneous (7.2 Technical cleanliness)

For metallic particles, the following applies per connector:	CCC = N (J4/K0) acc. to VDA, Band 19
For all other particles, the following applies per connector:	CCC = N (J10/K0) acc. to VDA, Band 19



7.2.2 Customer: BMW

The BMW-specific requirements according to QV11738028 for assembled connectors are visible in “**Table 7.2**”. The information on surfaces can be found in the customer drawings. Soft fibers are not considered in the assessment of non-metallic particles, provided they meet the QV requirements.

Table 7.2: Overview 4.0 mm² & 6.0 mm² SCC technical cleanliness requirements for Customer: BMW (7.2 Technical cleanliness)

Technical cleanliness acc. to QV11738028			
HV system (assembled final product without cable)			
TecSa requirement class (t.b.d. -> BMW - manufacturer)			
Reference size A (1,000 cm ²)			
Number of allowable particles by length size class			
		Non-metallic particles	Metallic particles
G	150 - 200 µm	-	-
H	200- 400 µm	1,200	1,200
I	400 – 600 µm	130	130
J	600 – 1,000 µm	60	15
K	1,000 – 1,500 µm	4	-
L	1,500 – 2,500 µm	-	-
Limit value for the maximum permissible particle size X			
	X-all [µm]	1,500	1,000
	x/3-all[µm]	1,500	1,000

7.3 Automation possibilities

There is a concept from Komax Holding AG in which the processing steps as shown in this processing specification can be implemented in various stages of automation. This concept was developed jointly between Komax Holding AG and Hirschmann Automotive GmbH. The commissioning is the responsibility of the processor and can be requested directly from Komax Holding AG.

7.4 Sample preparation for shielding retention force

This chapter details the test setup in connection with **Chapter “3.10.1 Cable shielding crimping using two half-shells”** and **Chapter “Error! Reference source not found. Error! Reference source not found.”** for the HPS40-2 2+2 female connector SCC 4.0 mm² and HPS40-2 2+2 female connector SCC 6.0 mm².

To check the shielding retention force, the test specimens must be prepared accordingly. If production without HCT4 female terminals is not possible, additional manipulation options are described below. It is important to note that the manipulated connectors are to be used exclusively for testing purposes and must not be used in vehicles!

7.4.1 Manipulation of primary and secondary locking

This method of manipulation is applicable if production without HCT4 female terminals is not possible. For this, the locking hooks of the HCT4 female terminal must be bent inwards, for example with a screwdriver. Additionally, the locking hook of the secondary lock must be bent inwards and removed, as shown in **“Figure 7.1”**.

Figure 7.1: Representation 4.0 mm² & 6.0 mm² SCC manipulation of primary and secondary locking (7.4 Sample preparation for shielding retention force)

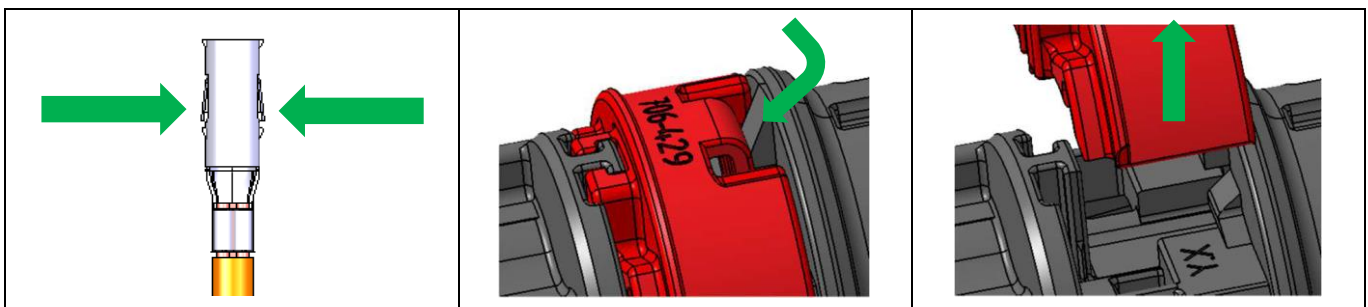



7.4.2 Removal of HCT4 female terminals after shielding crimping

This method of manipulation is applicable if production without HCT4 female terminals is not possible and the manipulation method in **Chapter “7.4.1 Manipulation of primary and secondary locking”** cannot be implemented either. In this case, the gray-marked area, as shown in **“Figure 7.2”**, must be removed, for example by cutting.

Figure 7.2: Representation 4.0 mm² & 6.0 mm² SCC removal of HCT4 female terminals after shielding crimping (7.4 Sample preparation for shielding retention force)

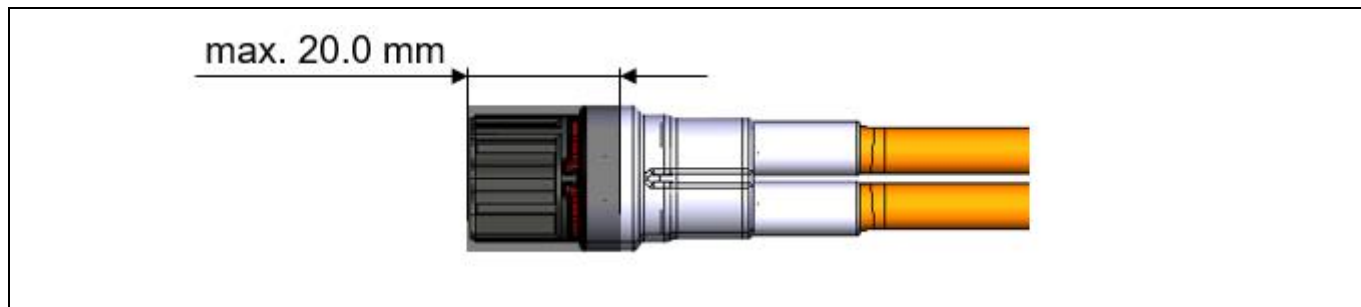



8 Appendix

The test machines and devices described in this chapter were used at Hirschmann Automotive GmbH to build various test and validation parts. The selection, design, and commissioning of the machines and devices are the responsibility of the processor.

Table 8.1: Overview single stroke crimping machine for 3.4 Remove shielding foil (if present), trim shielding braid, and crimp the ferrule crimp (8 Appendix)

Article Usage	3.4 Remove shielding foil (if present), trim shielding braid, and crimp the ferrule crimp
Article Type	Single stroke crimping machine
Article description supplier	Crimp-Device Crimp-Ferrule HPS40-2 SCC
Article number supplier	EPS2001-HPS40-2-SCC
Contact information supplier	Schaefer Werkzeug- und Sondermaschinenbau GmbH Dr.-Alfred-Weckesser-Str. 6 76669 Bad Schoenborn-La, Deutschland Tel: +49 7253 9421-0 Fax: +49 7253 9421-94 www.schaefer.biz

Table 8.2: Overview double stroke crimping machine for 3.6 Crimp the HCT4 female terminal & 4.5 Crimp the HCT4 female terminal (8 Appendix)

Article Usage	3.6 Crimp the HCT4 female terminal 4.5 Crimp the HCT4 female terminal
Article Type	Double stroke crimping machine
Article description supplier	HPS40-2 Double stroke crimping machine
Article number supplier	EPS2001-HPS40-2
Article description supplier	Interchangeable crimping unit
Article number supplier	Shown in process specification HCT4 female terminal EVS-100068
Contact information supplier	Schaefer Werkzeug- und Sondermaschinenbau GmbH Dr.-Alfred-Weckesser-Str. 6 76669 Bad Schoenborn-La, Deutschland Tel: +49 7253 9421-0 Fax: +49 7253 9421-94 www.schaefer.biz



Table 8.3: Overview pressing device for 3.10 Crimp the shielding sleeve & 4.9 Crimp the shielding sleeve (8 Appendix)

Article Usage	3.10 Crimp the shielding sleeve 4.9 Crimp the shielding sleeve
Article Type	Pressing device
Article description supplier	Pressing device HPS40-2 SCC
Article number supplier	EPS3000-HPS40-2
Contact information supplier	Schaefer Werkzeug- und Sondermaschinenbau GmbH Dr.-Alfred-Weckesser-Str. 6 76669 Bad Schoenborn-La, Deutschland Tel: +49 7253 9421-0 Fax: +49 7253 9421-94 www.schaefer.biz

Table 8.4: Overview hand lever press for 5.1 Assemble the locking sleeve (8 Appendix)

Article Usage	5.1 Assemble the locking sleeve
Article Type	Hand lever press
Article description supplier	Assembling device HPS40-2
Article number supplier	HPS40-2
Contact information supplier	WKM – Maschinenbau GmbH Oberes Ried 15 6833 Klaus, Austria Tel: +43 5523 54907 Fax: +43 5523 54907-50 www.wkm.at

Table 8.5: Overview hand lever press for 6.1 Assemble the In-Line CPA cover (8 Appendix)

Article Usage	6.1 Assemble the In-Line CPA cover
Article Type	Hand lever press
Article description supplier	Assembly device horizontal positioning assembly group
Article number supplier	197079
Contact information supplier	WKM – Maschinenbau GmbH Oberes Ried 15 6833 Klaus, Austria Tel: +43 5523 54907 Fax: +43 5523 54907-50 www.wkm.at



Table 8.6: Overview various stages of automation for 7.3 Automation possibilities (8 Appendix)

Article Usage	7.3 Automation possibilities
Article Type	Various stages of automation
Article description supplier	Concept of automation HPS40-2
Article number supplier	N/A
Contact information supplier	Komax Holding AG Industriestraße 6 6036 Dierikon, Switzerland Tel: +41 41 455 04 55 www.komaxwire.com



9 Change of documentation

Version	Change description	Change date	Editor
11	Updated 6.0 mm ² Version	11/ 2019	Hoor R.
12	Activated 6.0 mm ² cables; put L10 and L11 in brackets (3.0mm ² , 4.0 mm ² 5.0 mm ²); updated 6.0 mm ² version	12/ 2019	Hoor R.
13	Updated L1 / L2 / L3 / L7 / width of shield-crimping geometry	01/ 2020	Hoor R.
14	Added L4/L5 (6.0 mm ²); put L8 and L9 in brackets (6.0 mm ²), removed obsolete cables; added visual check of terminals	02/ 2020	Hoor R.
15	Added Aluminium-wire; adapted L7 (4.0 mm ²) and L5 (6.0 mm ²); defined measurement for ØX (4.0mm ²); permitted residual foil; added comment for L3; added L4* (6.0 mm ²); added comments for the assembly of the seal	04/ 2020	Hoor R.
16	added BMW-Documents No.; permitted deviation of processing sequence for 4.0 mm ² / specified measurement of L5 for 4.0 mm ² / specified measurement of L12 for 4.0 mm ² and 6.0 mm ² / added process data for 6.0 mm ² aluminium conductors;	05/ 2020	Hoor R.
17	L3 was made theoretical, additional comments on the positioning of the strain-relief and x-ring were added; non-existing components for 3.0 mm ³ and 5mm ² were crossed out/ Coficab was reactivated added clamping of the wires during assembly of the shield sleeve	11/ 2020	Hoor R.
18	Added BMW F-characteristics; updated clamping Removed 3.0 mm ² and 5.0 mm ² / Corrected continuity errors (administrative) Added optional stripping length for new terminal holders (6.0mm ²)/ Added Appendix for sample preparation	01/ 2021	Hoor R.
19	Increased for 6.0 mm ² the tolerance and added measuring plane for shield-crimping (d)	04/ 2021	Bas Ü.
20	In chapter 1.5, a special configuration has been defined for the FHLR91XC91X T4 6.0 mm ² cable.	05/ 2021	Engstler D.
21	Added link to alu appendix, added alternative embossing geometry for 4.0 mm ² wires;	11/ 2021	Breuss L.
22	In chapter 1.5, the special configuration has been adapted for the FHLR91XC91X T4 6.0mm ² cable.	05/ 2022	Engstler D.
23	Deleted 1x4mm ² Kroschu cable Changed cleanliness requirement and added BMW specific requirement based on surface reference/ BMW special characteristics changed acc. to OEM requirement/ Added chapter 5.4.- 5.7 (positioning CPA Housing for Inline SCC connector, 90° angled cap, coding clip on angled cap, transport protection);	10/ 2022	Breuss L.
24	Update design specification	06/ 2023	Jussel E-M.
25	Adjusting data of the bottom line	07/ 2023	Jussel E-M.
26	Update of page 3,5,6,8,9,14,15,31,	08/ 2023	Jussel E-M.
27	Topic 1.2: adjusted with additional "Miscellaneous" Page 67: update layout, picture, additional statement	10/ 2023	Jussel E-M.
28	Topic 1.1: updated the table Page 37: additional comment of usage version Page 39, 61: "Embossing height "d" – table updated	10/ 2023	Jussel E-M.



29	Complete revision of the processing specification: Structure, layout, illustrations, dimension designations, clear text descriptions, general texts, etc. The build-up of the connector itself has not changed. Implemented changes cannot be listed here, as every single page is affected. Please read through the processing specification thoroughly again if necessary.	12/ 2023	Natter T.
30	Change Kroschu drawing no. OLD: 64998373 NEW: 64998762 Added a new wire from Aptiv: M8979 FHRLR91XC91X-C 6.0 mm ²	02/ 2024	Jussel E-M.
31	Page 16: Changed wire description and Aptiv no. Page 28: Changed wire description and Aptiv manufacturing plant	02/ 2024	Jussel E-M.
32	Additional Aptiv wire 4.0mm ² „ <i>wait for OEM approval</i> ”	10/ 2024	Jussel E-M.
33	Page 16) Updated the PN number of topic “Q” Page 20, 24) Change of Index 807-656-501 to -541 Page 26,27) Adjust information of wire “Aptiv” Page 29) Additional index	11/ 2024	Jussel E-M.
34	Additional Aptiv wire 4.0mm ² approved	02/ 2025	Jussel E-M.