

HIRSCHMANN AUTOMOTIVE HEATED eThrottle

Contactless Angular Position Sensor
based on the Hall Effect

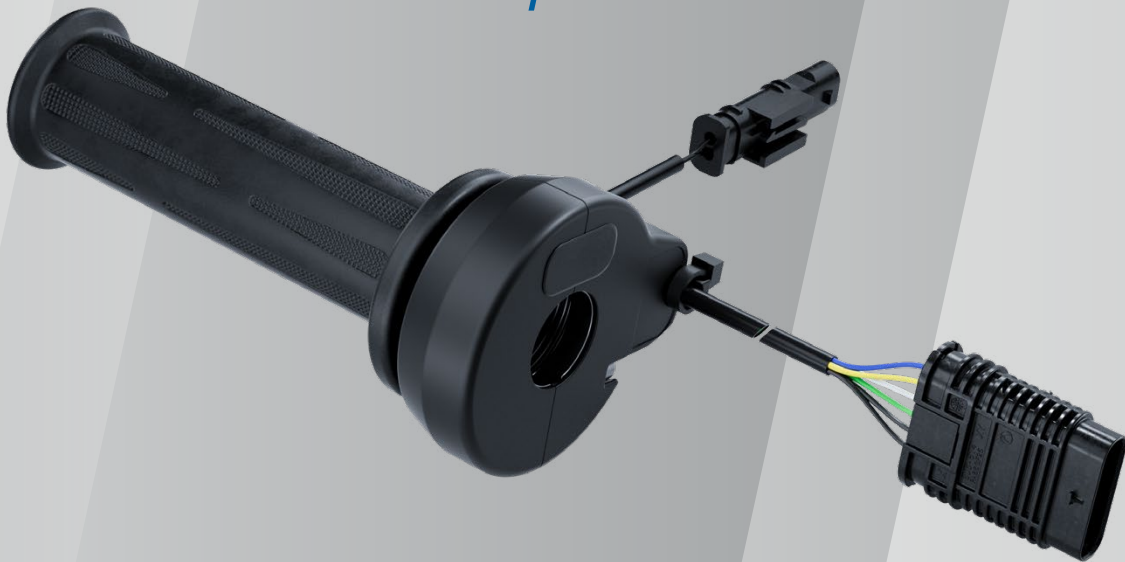

HIRSCHMANN
AUTOMOTIVE

HIRSCHMANN AUTOMOTIVE HEATED eTHROTTLE FOR RIDE BY WIRE

Our electronic throttle for ride by wire is based on the Hall Effect. The other features are also convincing.

This heated eThrottle is an in-house development of Hirschmann Automotive. The system recognizes the driver's desired pace and converts it into a signal to control the speed of motorcycles, motor scooters, or all-terrain vehicles. A grip heater is also installed to keep the driver's hands warm.

Functional Principle

At first, the contactless Hall Effect rotary system registers the operating angle of the throttle. This information is then converted into an electrical signal that is subsequently processed by the control unit. The linear mapping of the rotation angle enables the customer to analyze different evaluations regarding driving dynamics and performance.

Product Range

The Hirschmann Automotive Heated eThrottle is offered as a complete system. It includes cables, connectors, and a clamping profile for mounting on the handlebars. On top of that, the eThrottle is available with integrated heating.

Particularly noteworthy is that the eThrottle grip is effectively shielded against electromagnetic fields, which for example can be caused by magnets for tank bags. In addition, it meets all safety requirements for electronic gas systems. Therefore, the sensor system makes a decisive contribution to meeting the Euro 4 and Euro 5 standards.



Characteristics:

- contactless full redundant sensor based on the Hall effect
- immune to magnetic and electromagnetic interference thanks to the integrated shielding function
- robust, even under challenging environmental conditions
- compliant with automotive standards
- application-specific rotation possible
- optional customized signal settings
- optional overclosing up to 10° possible
- left fixed handle is also available
- suitable for Euro 4 and 5 vehicles

TECHNICAL PRODUCT INFORMATION

	DESIGNATION	MIN. VALUE	TYPE VALUE	MAX. VALUE
OPERATING TEMPERATURE	TOP	-20° C		85° C
ROTATION ANGLE	ROT	-10°		80°
OPERATING TORQUE	MOP	0.4 Nm		0.6 Nm
SUPPLY VOLTAGE	VDD	4.5 V	5 V	5.5 V
SUPPLY CURRENT	I _{dd}		13.5 mA	15 mA
SIGNAL RANGE	VOUT	6.0 %VDD		90 %VDD
DIAGNOSTIC LOW	diag_low	0 %VDD		4.0 %VDD
DIAGNOSTIC HIGH	diag_high	96 %VDD		100 %VDD
LINEARITY ERROR	lin_error	-2 %		2 %
SYNCHRONISM ERROR	sync_error	-2 %		2 %
HANDLE BAR DIAMETER		22.0 mm		22.15 mm
SIGNAL CABLE LENGTH		750.0 mm		850.0 mm
HEATING CABLE LENGTH			600.0 mm	
IP CLASS			IP69k	

TECHNICAL PRODUCT INFORMATION FOR THE HEATING

	OPTION 1	OPTION 2
OPERATING VOLTAGE	12 V	12 V
RESISTANCE	10 Ω	5 Ω
CURRENT	1.2 A	2.4 A
POWER	14.4 W	28.8 W



LEFT SIDE WITH INTEGRATED HEATING



HEATED eTHROTTLE

RECOMMENDED COUNTER PART

	SIGNAL CONNECTOR	HEATING CONNECTOR
HOUSING	Hirschmann Automotive No.: 805-124-561	Hirschmann Automotive No.: 805-120-521
TERMINAL	Kostal No.: 3 21 24 73412 0	Kostal No.: 3 21 24 73412 0
SWS	Kostal No.: 1 08 00 50725 0 7160-8234	Kostal No.: 1 08 00 50725 0 7160-823412 V

SIGNAL REDUNDANT

The following diagram shows the course of the sensor signal from our standard Hirschmann Automotive Heated eThrottle with 65° rotation angle and overclosing.

Sensor Signal Characteristic

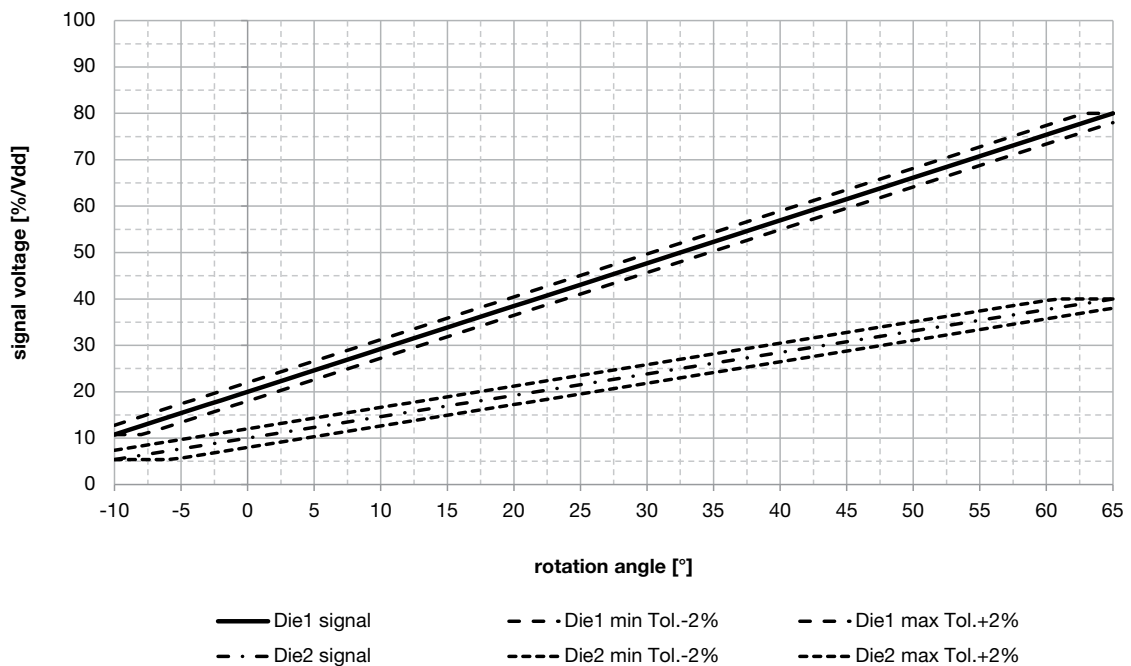

**Markus Kreuter is your Contact
for Individual Questions**

Account Manager Sensor Systems

+43 5522 307 1223

+43 664 338 200 6

markus.kreuter@hirschmann-automotive.com

SEEKING MORE DETAILED INFORMATION?
SCAN ME AND VISIT OUR WEBSITE.



Hirschmann Automotive GmbH

Oberer Paspelsweg 6–8
6830 Rankweil, Austria

www.hirschmann-automotive.com
shop.hirschmann-automotive.com

