

Blatt 1 gültig für den Wirtschaftsraum: EMEA SHEET 1 VALID FOR THE ECONOMIC AREA: EMEA

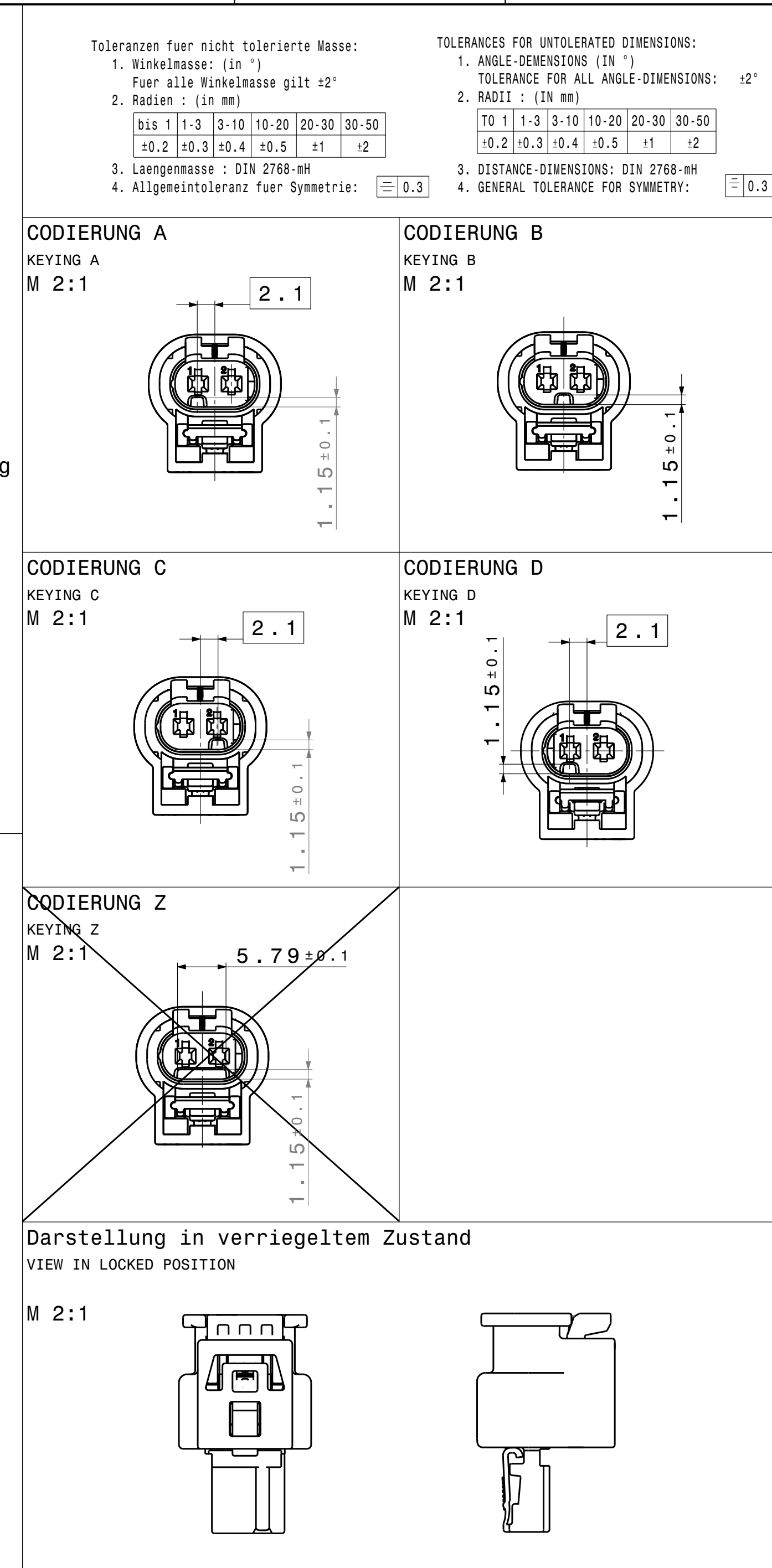
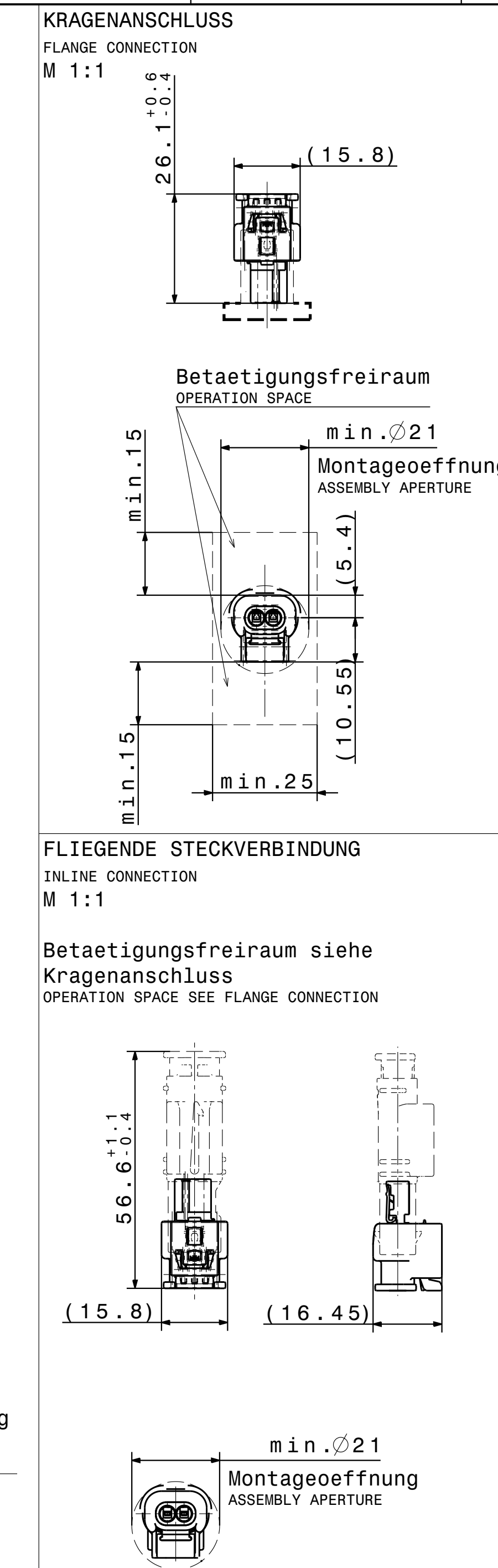
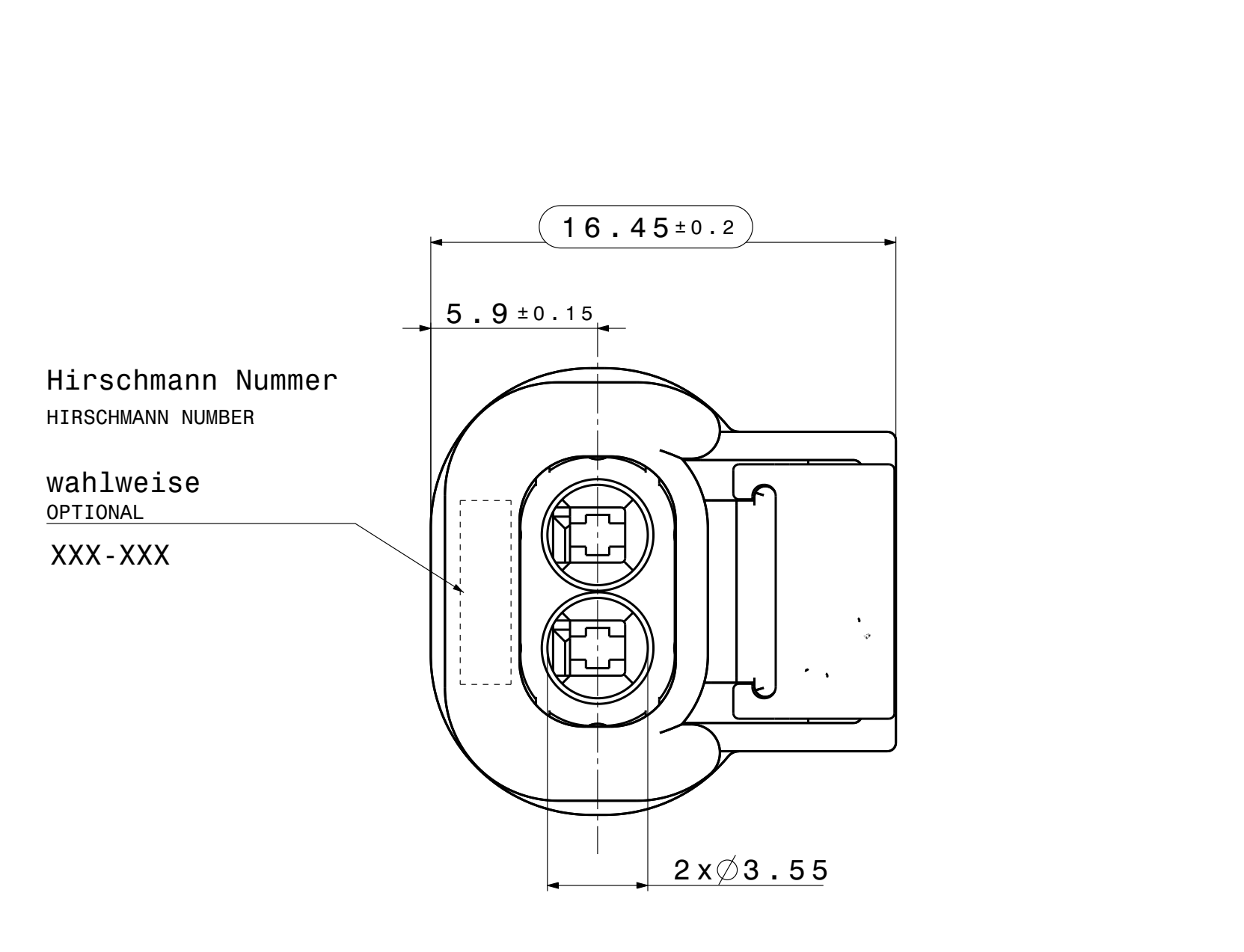
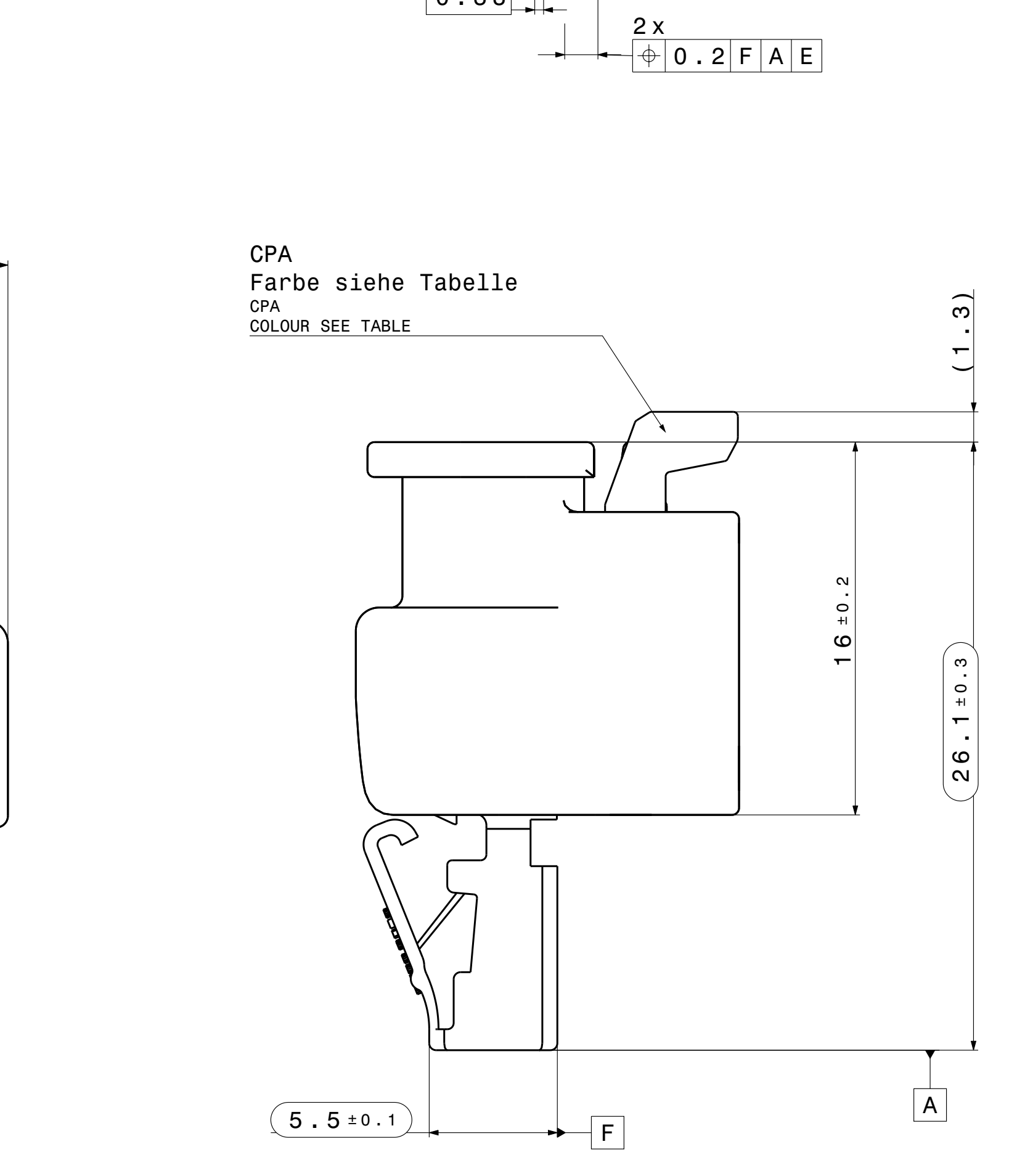
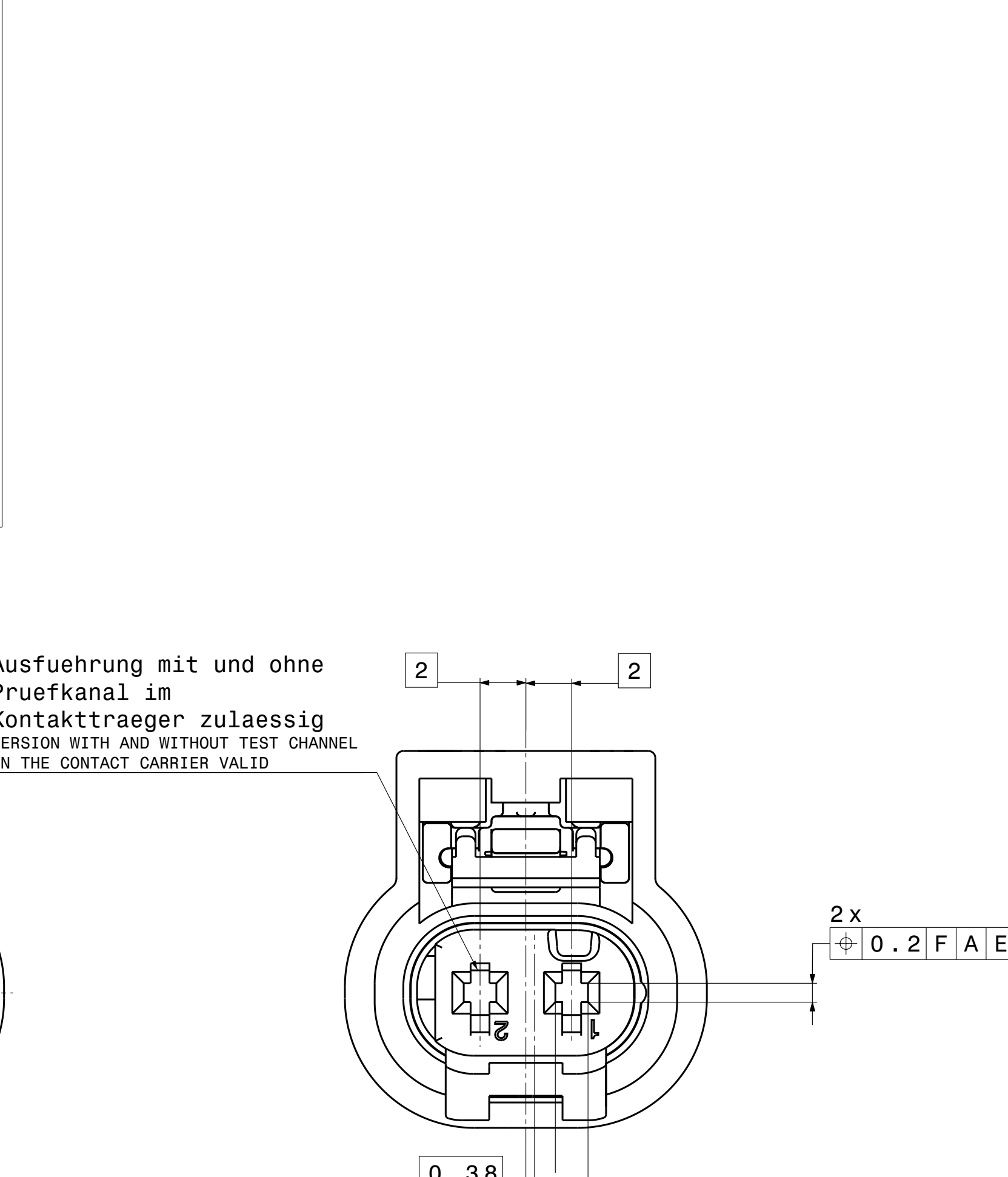

Lft.-Bestell Nr. ORDER-NO.	Cod. KEYING	Farbe Kontaktraeger COLOR CONTACT BASE	Farbe Schutzkragen COLOR PROTECTIVE SHROUD	Farbe Dichtung COLOR SEAL	Farbe CPA COLOR CPA	Variante OPTION	Bemerkungen COMMENTS
805-120-584	D	violett, aehnlich RAL 4004 VIOLET, SIMILAR RAL 4004				3	Standardausfuehrung BASIC VERSION
805-120-582	B	natur NATURE				3	Standardausfuehrung BASIC VERSION
805-120-581	A	schwarz, aehnlich RAL 9011 BLACK, SIMILAR RAL 9011				3	Standardausfuehrung BASIC VERSION
805-120-528	B	natur NATURE				4	Standardausfuehrung BASIC VERSION
805-120-526	A	currygelb aehnlich RAL 1027 YELLOW, SIMILAR RAL 1027	schwarz, aehnlich RAL 9011 BLACK, SIMILAR RAL 9011	transparent TRANSPARENT	natur NATURE	4	Standardausfuehrung BASIC VERSION
805-120-527	A	currygelb aehnlich RAL 1027 YELLOW, SIMILAR RAL 1027				2	Nicht fuer Neuanwendungen zulaessig. DO NOT USE FOR NEW APPLICATIONS.
805-120-523	C	blau aehnlich RAL 5012 BLUE SIMILAR RAL5012				1	Nicht fuer Neuanwendungen zulaessig. DO NOT USE FOR NEW APPLICATIONS.
805-120-522	B	natur NATURE				1	Nicht fuer Neuanwendungen zulaessig. Ersetzt durch 805-120-582 DO NOT USE FOR NEW APPLICATIONS. REPLACEMENT BY 805-120-582
805-120-521	A	schwarz, aehnlich RAL 9011 BLACK, SIMILAR RAL 9011				1	Nicht fuer Neuanwendungen zulaessig. Ersetzt durch 805-120-581 DO NOT USE FOR NEW APPLICATIONS. REPLACEMENT BY 805-120-581

Lft.-Bestell Nr. ORDER-NO.	Cod. KEYING	Farbe Kontaktraeger COLOR CONTACT BASE	Farbe Schutzkragen COLOR PROTECTIVE SHROUD	Farbe Dichtung COLOR SEAL	Farbe CPA COLOR CPA	Variante OPTION	Bemerkungen COMMENTS
805-120-584	D	violett, aehnlich RAL 4004 VIOLET, SIMILAR RAL 4004				3	Standardausfuehrung BASIC VERSION
805-120-582	B	natur NATURE				3	Standardausfuehrung BASIC VERSION
805-120-581	A	schwarz, aehnlich RAL 9011 BLACK, SIMILAR RAL 9011				3	Standardausfuehrung BASIC VERSION
805-120-528	B	natur NATURE				4	Standardausfuehrung BASIC VERSION
805-120-526	A	currygelb aehnlich RAL 1027 YELLOW, SIMILAR RAL 1027	schwarz, aehnlich RAL 9011 BLACK, SIMILAR RAL 9011	transparent TRANSPARENT	natur NATURE	4	Standardausfuehrung BASIC VERSION
805-120-527	A	currygelb aehnlich RAL 1027 YELLOW, SIMILAR RAL 1027				2	Nicht fuer Neuanwendungen zulaessig. DO NOT USE FOR NEW APPLICATIONS.
805-120-523	C	blau aehnlich RAL 5012 BLUE SIMILAR RAL5012				1	Nicht fuer Neuanwendungen zulaessig. DO NOT USE FOR NEW APPLICATIONS.
805-120-522	B	natur NATURE				1	Nicht fuer Neuanwendungen zulaessig. Ersetzt durch 805-120-582 DO NOT USE FOR NEW APPLICATIONS. REPLACEMENT BY 805-120-582
805-120-521	A	schwarz, aehnlich RAL 9011 BLACK, SIMILAR RAL 9011				1	Nicht fuer Neuanwendungen zulaessig. Ersetzt durch 805-120-581 DO NOT USE FOR NEW APPLICATIONS. REPLACEMENT BY 805-120-581

- ### Bemerkungen: COMMENTS:
- Codierung A Variante 1 gezeichnet
KEYING A DRAWN
 - Auslieferungszustand wie gezeichnet
DELIVERY STATUS AS DRAWN
 - massgebend ist der deutsche Text
GERMAN TEXT IS VALID
 - Funktionsbestimmende Masse, die mit \varnothing gekennzeichnet sind, werden im EMPB dokumentiert. Nicht gekennzeichnete Masse werden ebenfalls ausgemessen, aber nicht in EMPB dokumentiert. Abweichungen sind zu korrigieren.
DIMENSIONS MARKED WITH \varnothing ARE DOCUMENTED IN THE INITIAL SAMPLE INSPECTION REPORT (ISR). UNMARKED DIMENSIONS ARE ALSO MEASURED BUT NOT DOCUMENTED IN THE ISR. VARIATIONS MUST BE CORRECTED.
 - Max. zulaessiger Leitungsquerschnitt 1,00mm² FLR
MAXIMUM CONDUCTOR CROSS SECTION 1,00mm² FLR
 - Max. zulaessiger Leitungsdurchmesser 2,10mm
MAXIMUM CONDUCTOR DIAMETER 2,10mm
 - Kammer passend fuer
MCP 1.2-LL siehe Tyco-Zeichnung C-1452674 oder
WLK-Sm Stecknelse siehe KOSTAL-Zeichnung DCC00079128
MATCHING RECEPTACLE SEE
MCP 1.2-LL SEE TYCO DRAWING C-1452674 OR
WLK-SM RECEPTACLE SEE KOSTAL DRAWING DCC00079128
 - passend zu Ausfuehrungsvorschrift 872-975-...00
MATCHING TO SPECIFICATION 872-975-...00
 - passend zu 2-POL 1.2 Stecker ELA 872-863-...00
MATCHING TO 2-WAY 1.2 MALE HOUSING 872-863-...00
 - Produkt- und Verarbeitungsspezifikation
PRODUCT AND PROCESSING SPECIFICATION
HRW-Nr. EPS-100011-00
EVS-100013-00
 - Schutzklasse IPX7 / IPX9K
PROTECTION CLASS IPX7 / IPX9K
 - max. 30% Regranulat zulaessig
MAX. 30% REGRANUL ACCEPTABLE
 - Teilekennzeichnung angelehnt an DIN 1451
PART IDENTIFICATION SIMILAR DIN 1451
 - Teil entspricht Altautorichtlinie nach EU-Altfahrzeugverordnung 2000/53/EG
PART CORRESPONDS TO SCRAP CAR WITHDRAWAL ...
 - passende Schutzkappe / Wellrohranschluss
Fa. Schlemmer 7806793, 7806796, 7806895
MATCHING PROTECTIVE SHROUD
FA. SChLEMMER 7806793, 7806796, 7806895
 - Aendierungen die den technischen Fortschritt diesen, behalten wir uns vor!
CHANGES BASED ON TECHNICAL PROGRESS ARE IN THE DECISION OF THE MANUFACTURER!

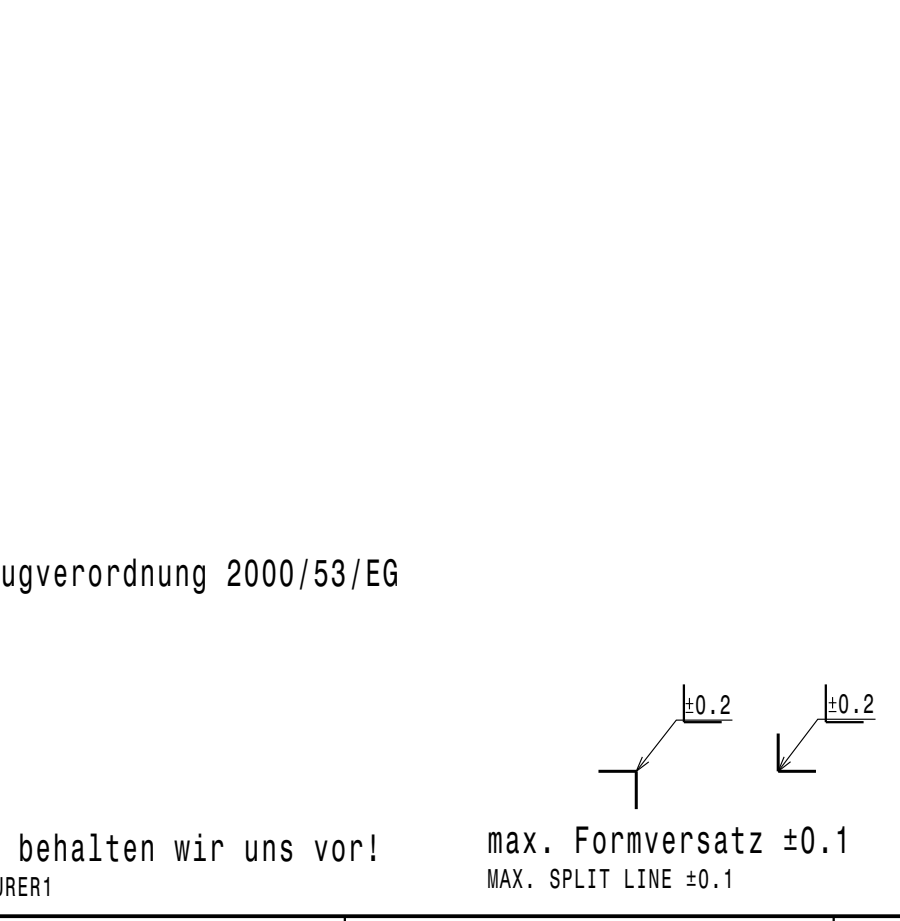

NO.	DATE	DESCRIPTION OF CHANGES	DATE	BY	REASON
12	13.03.2023	Sheet 2 805-120-526 added;			
11	14.12.2018	Sheet 1 and 2 Index -526 added			
10	13.06.2017	Sheet 1 805-120-521, -522, -523 & 527 CPA color in nature changed			
09	18.01.2017	Sheet 1 805-120-529 added;			
08	13.10.2016	Sheet 2 added;			
07	22.09.2016	Index -528 added; option 3 activated; extended the comments;			
06	19.06.2015	Index -528 and Index -523 added;			
05	06.10.2014	Index -528 added;			
04	23.05.2014	Index -531 added;			
03	16.03.2007	Index -507 added!			

DESCRIPTION OF CHANGES

DATE

BY

REASON

12

11

10

09

08

07

06

05

04

03

13

14

15

16

17

18

19

20

21

22

23

24

25

26

27

28

29

30

31

32

33

34

35

36

37

38

39

40

41

42

43

44

45

46

47

48

49

50

51

52

53

54

55

56

57

58

59

60

61

62

63

64

65

66

67

68

69

70

71

72

73

74

75

76

77

78

79

80

81

82

83

84

85

86

87

88

89

90

91

92

93

94

95

96

97

98

99

100