

2- to 8-way
1.2 SealStar M Connector
Generation 2





Index

- 1. General information 3**
 - 1.1 Introduction 3
 - 1.2 Applicable documents 4
- 2. Technical characteristic 5**
 - 2.1 Operating temperature 5
 - 2.2 Degrees of protection 5
 - 2.3 Retention force of contacts in 1.2 SealStar female connector or male connector 5
 - 2.4 Mounting and demounting forces 5
 - 2.5 Characteristic of contact System 5
 - 2.6 Material 5
- 3. Delivery condition / product components 6**
- 4. Test requirements 7**
 - 4.1 Features and test description 7
 - 4.1.1 Dimensional inspection 7
 - 4.1.2 Electrical requirements 7
 - 4.2 Mechanical requirements 8
 - 4.2.1 Material and surface analysis 8
 - 4.2.2 Contact engagement length 8
 - 4.2.3 Interaction between contact and housing 9
 - 4.2.4 Handling and functional reliability of the housing 10
 - 4.2.5 Insert and retention forces of the contact parts in the housing 12
 - 4.2.6 Scoop-proofing 13
 - 4.2.7 Housing influence on the derating 13
 - 4.2.8 Vibration 14
 - 4.3 Environmental requirements 16
 - 4.3.1 Climate load of the housing 16
 - 4.3.2 Long-term temperature aging 17
 - 4.3.3 Chemical resistance 18
 - 4.3.4 Water leak tightness 19
 - 4.3.5 Locking noise 21
 - 4.3.6 Retention force of the blind plugs 22
- 5. Appendixes 23**
 - 5.1 Appendix A insulation resistance (in mΩ) 23
 - 5.2 Appendix A.1 determination of the contact resistance 23
 - 5.3 Appendix B severity 24
 - 5.4 Appendix C vibrator table mounting 25
 - 5.5 Appendix D drop test in drum 25
 - 5.6 Appendix E media list 26
 - 5.7 Appendix F schematic of the measurement setup “volume measurement” 26
- 6. Performed test matrix 27**
 - 6.1 1.2 SealStar M Connector 27
- 7. Revision table 27**

1. General information

1.1 Introduction

This product specification is valid for 1.2 SealStar M connector Gen2 and describes their properties, executed tests and requirements.

In case of doubt, this specification has priority over the following documents.

The documents named below, provided that reference is made to them, are part of this specification. In the event of a contradiction between this specification and the product drawing or a contradiction between this specification and the documents listed, this specification takes precedence. In the event of discrepancies, the German text applies

In case of inappropriate use deviating from this specification and the applicable documents and resulting quality problems, the right of recourse will be rejected.

Detailed test reports are not published but can be inspected on site.

All test specimens must be described such as customer number, test specimen designation, date of manufacture, country of manufacture, material, contact system used, cable used, mould cavity, supplier part number.

This also applies to the corresponding counterparts (e.g. inline connectors, fixtures, contacts, etc.).

In all tests, it must be ensured that the test items comply with the valid customer drawing documents and product and processing specifications.

The measurement frequency for continuous monitoring of the measured values is defined for the relevant tests. The measured values must be recorded, save and displayed for later evaluation.

Unless otherwise stated, all tests must be performed with series production parts. Sorting out, lubricating, cleaning or similar manipulations are not permitted.

All tensile tests must be performed at a speed of 50 mm/min. Deviations must be documented.

Product-specific deviations can be found in the respective DVP overview!

Not all the above approval tests have been carried out for all numbers of poles!
See performed test matrix.



1.2 Applicable documents

a)	Processing specification EVS-100121-00	1.2 SealStar Male connector
b)	Product specification DOC00076784	Kostal “Mini Lamellen” Contact MLK 1.2
c)	Processing specification DOC00061540	
d)	Tab contact MLK 1,2 DOC00082069	
e)	Product specification 108-18782	Tyco Electronics MCON-1.2-Contact System
f)	Processing specification 114-18464	
g)	Tab contact 1.2mm C-1418754	
h)	DIN EN 60352-2	Solderless electrical connection part 2: crimp connection
i)	DIN EN 60512	Connectors for electronic equipment- Tests and measurements
j)	DIN EN 60529	Degrees of protection provided by enclosures (IP-code)
k)	PF.90012	Performance Specification for Automotive Electrical Connector Systems

2. Technical characteristic

2.1 Operating temperature

Temperature range.

For contacts, see product specification of contact systems

Temperature range for the plastic used

-40°C up to +130°C for a time range of 3000h. Short-term temperature max. 150°C over a time 300 h, see plastic material data sheet.

2.2 Degrees of protection

When using 1.2 contacts with seal: IPX7 / IPX9K

The single wire seal must not be exposed unprotected to the steam jet.

The application of cover caps for the female connectors is permitted during the protection class test.

2.3 Retention force of contacts in 1.2 SealStar female connector or male connector

max. contact removal force from 1.2 SealStar female connector or male connector:

F_{primary}	≥55N
$F_{\text{secondary}}$	≥55N

2.4 Mounting and demounting forces

Max. mounting force of 1.2 SealStar female connector into 1.2 SealStar male connector:

(worst-case calculation)	2- to 8-pol:	F	≤80N
typically measured values		F	<75N

Min. retention force of 1.2 SealStar female connector into 1.2 SealStar male connector:

F	≥100N
---	-------

Max. locking force of the secondary locking mechanism:

F	≤50N
---	------

2.5 Characteristic of contact System

Max. permitted conductor cross section:	1,0 mm ² with Seal		
Max. permitted conductor diameter:	see released drawing of contact manufacturer		
Max. terminal insertion force:		F	≤30N

2.6 Material

Information of this can be found on the customer drawings.

3. Delivery condition / product components

The connector, consists of a contact housing and TPA. The connector is pre-assembled and the TPA is open.

TPA = Terminal Position Assurance

In very rare cases, it may occur that the locking bar moves into final locking position and closes the secondary lock. In the case of the closed secondary lock, this can be adjusted according to the handling manual to be returned to the initial state

symbol image

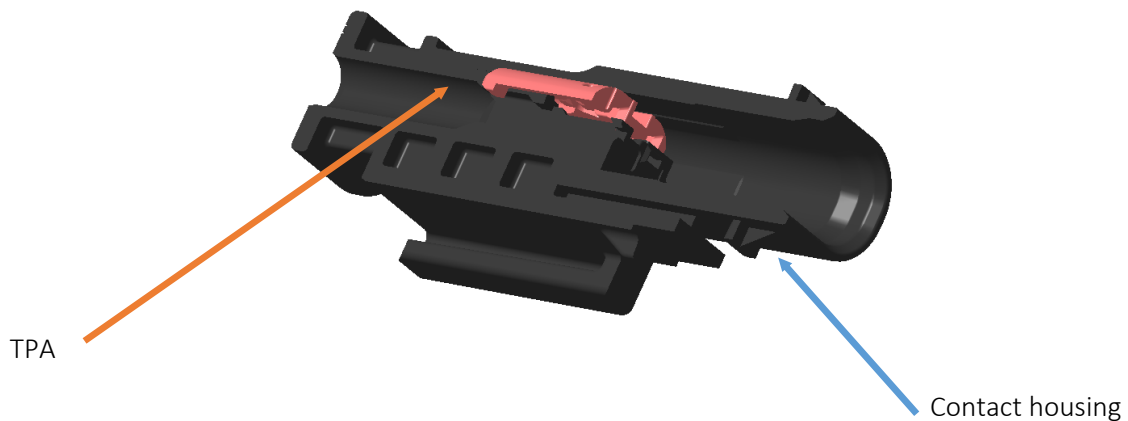

4. Test requirements

4.1 Features and test description		
4.1.1 Dimensional inspection		
Description	Requirement	Procedure/Notes
Dimension	Fulfilment of the customer's drawing or product specification.	DIN EN 60512-1-1 characteristics 3a, 3b, 3d to 3g
<p>Note: Batch size: 1 piece per tool or mould cavity Housings: all variants</p> <p>Requirement: Dimensions must be conform to the customer drawings.</p>		

4.1.2 Electrical requirements		
Description	Requirement	Procedure/Notes
Contact resistance	Test voltage on ≤ 20 mV direct voltage (DC), Test time: 60s Contact resistance data: see appendix A as appendix A.1 resistance measurement 1	DIN EN 60512-2-1, "millivolt level method" measurement: 4.1
Insulation resistance	Direct voltage (DC) from 500V ± 50 V Test time: 60s Insulation resistance: >100 M Ω	DIN EN 60512-3-1 Connection type: A
<p>Note: Batch size: one housing per mould cavity (fully equipped) or at least 10 contacts parts split over at least 2 housings. Contact part: any type</p> <p>Requirement: For resistances, the initial value, final value, standard deviation and the resistance change of the respective DUTs in each case. DUT = device under test</p>		



4.2 Mechanical requirements		
4.2.1 Material and surface analysis		
Description	Requirement	Procedure/Notes
Visual inspection	Visual inspection Injection mould cavities skins, tool offset and mould cavity separation marks must be not impair the handling or function, are permissible within the drawing requirements.	DIN EN 60512-1-1 characteristics 3a, 3b, 3d to 3g
Material analysis	Documentation of the materials: - Material certificate + Identification of all materials (IMDS) - The RAL colours (for all keying) Documentation of the surface quality: - Measurement of maximum permissible burrs at the function-relevant locations	
Identification on the surface	Housing identification, according to customer drawing	
<p>Note: Batch size: 1 piece per mould cavity Housings: all variants</p>		

4.2.2 Contact engagement length		
Description	Requirement	Procedure/Notes
Contact engagement length	- Contact engagement length: >1.00mm - Tolerance calculation	Tolerance calculation
<p>Requirement: A tolerance calculation with dimensional specification is required.</p>		

4.2.3 Interaction between contact and housing		
Description	Requirement	Procedure/Notes
Drop test	Secondary lock in the pre-engagement position	DIN EN 60068-2-31
	Secondary lock in the end- position	
Visual inspection	Secondary lock in the pre- engagement position must not close in the drop test. Secondary lock in the end- position must not open in the drop test. The test objects must not be damaged. Damage must be documented.	DIN EN 60512-1-1 characteristics 3a, 3b, 3d to 3g
Locking force of the secondary locking mechanism	Locking force of the secondary locking mechanism values, see point 2.4 mounting and demounting forces	-
<p>Note:</p> <p>Batch size:</p> <p>Drop test:</p> <ul style="list-style-type: none"> 3 unequipped housings for secondary lock in the pre-engagement position 3 fully equipped housings for secondary lock in the end- position (cables are cut off directly behind the housing) <p>Locking force of the secondary locking mechanism: 3 unequipped housings</p> <p>Contact part: any type</p> <p>Requirement for drop test: To test the housing stability and the locks, the housings are tested in a rotating drum. Drop test in drum, see appendix D</p> <p>Secondary lock in the pre-engagement position Secondary lock in the end- position</p> <p>Test at room temperature (RT) according to ISO 554-23/50 ordinary All test objects are tested at the same time Rotational speed: e.g. 3 rpm (the speed must be set so that all parts strike in the drop area) Number of revolutions: 30 Thickness of the steel plate in the drop area: at least 5 mm</p>		



4.2.4 Handling and functional reliability of the housing		
Description	Requirement	Procedure/Notes
Visual inspection	Determining a target state	DIN EN 60512-1-1 characteristics 3a, 3b, 3d to 3g
Insertion force/ actuation force	<p>Insertion force or actuation force for insertion and removal aids (fully equipped housings)</p> <p>values, see point 2.4 mounting and demounting forces</p> <p>The insertion force in plugging direction or actuation force of the insertion removal aid must be measured. The insertion force (including for insertion aids) must always be measured in the actuation direction. The DUTs must be fastened in the tensile testing machine with suitable holders so that the housings are not damaged or deformed.</p>	testing speed: 50 mm/min
Keying/polarizing	Error-proof design of housing (unequipped housings) criterion: $F > 3$ -times the insertion force (equipped housings) but at least $\geq 80N$	DIN EN 60512-13-5 testing speed: 50 mm/min
Retention force of housing latch/lock	<p>Retention force by open / closed CPA $F \geq 100N$</p> <p>Applicable to housings for inline and plug –in connections and device-mounted plug-in connections.</p> <p>If the connector housing has a CPA, the test must be performed both with the CPA open and with the CPA closed.</p> <p>The DUTs must be fastened in the tensile testing machine with suitable holders so that the housings are not damaged or deformed.</p> <p>The force must be applied opposite the plugging direction of the housings.</p> <p>The maximum force on the first displacement millimetre is defined as the retention force.</p>	DIN EN 60512-15-6 testing speed: 50 mm/min



CPA functional test	<p>- CPA actuation force when the housing is locked in the end position. - CPA opening force from end position to in pre-engaged position</p> <p>Values, see point 2.4 Mounting and Demounting Forces min. / max. mounting / demounting force of CPA from pre-engaged to locked position or locked to pre-engaged position.</p> <p>- CPA efficiency (pressing force of the CPA, up to the locked position) criterion: $F > 1,5$-times Insertion force but at least $\geq 80N$ It must not be possible to actuate the CPA if the housing is not locked in the end position.</p>	testing speed: 50 mm/min
Visual inspection	Determine deviations from a target state	DIN EN 60512-1-1 characteristics 3a, 3b, 3d to 3g

Note:

Batch size:

Insertion force: at least 10 equipped housings (included counterpart equipped)

Keying/Polarizing: at least 10 unequipped housings (included counterpart unequipped)

Retention force of the housing latch/lock: at least 10 (+10 if the housing has a CPA) complete connectors couplings without contacts.

To be carried out only if the housing has a CPA:

CPA function test: min. 10 unequipped housings (incl. counterpart) for actuation- and opening force
min. 10 unequipped housings for CPA efficiency

No cracks or fractures must occur in the entire housing including add-on parts (CPAs, locks, levers, sliders, film hinges, etc.). Actuated contact locks must not open as a result if the test.



4.2.5 Insert and retention forces of the contact parts in the housing		
Description	Requirement	Procedure/Notes
Visual inspection	Determining a target state	DIN EN 60512-1-1 characteristics 3a, 3b, 3d to 3g
Insert forces contact	Insert forces of the contact into the chamber Values, see point 2.5 Characteristic of Contact system	testing speed: 10 mm/min
Contact removal force from the housing	Contact pull out force - primary lock - secondary lock Values, see point 2.3 retention force of contacts	testing speed: 50 mm/min
Removal of the contacts three times with release tool	Removal of the contacts three times with release tool. Contact removal force from the housing, primary lock; Fulfilment of the lowest values from the contact removal force - primary lock.	testing speed: 50 mm/min
Visual inspection	Determine deviations from a target state	DIN EN 60512-1-1 characteristics 3a, 3b, 3d to 3g

Note:

Batch size:

Insert forces contact:

min. 1 equipped housing per mould cavity, but at least 10 contacts must be tested.

Contact removal force from the housing:

min. 1 equipped housing per mould cavity, but at least 10 contacts for primary lock

min. 1 equipped housing per mould cavity, but at least 10 contacts for secondary lock

Removal of the contacts three times with release tool:

min. 1 equipped housing per mould cavity, but at least 10 contacts must be tested.

The test specimens must be fixed in the tensile testing machine with suitable holders so that the housings are not damaged/deformed.

Insert forces contact:

The contacts are assembled in the chamber for contact insertion forces.

The contact insertion force is to be applied with a test device as close as possible to the cable connection in the insertion direction. During the test, make sure that the contact to be tested is snapped in.

The values must be measured and documented.

Contact removal force from the housing:

The contacts are assembled in the chamber for contact, during testing, it must be checked that the contacts are snapped in and then is a constant force applied to the contact from the front in axial direction and pulled out, this applied, constant force must be measured and documented.

4.2.6 Scoop-proofing		
Description	Requirement	Procedure/Notes
Scoop-proofing	It must be possible to touch signal- and current-carrying components (contacts) during removal/installation only with their signal- and current-carrying mating piece (and its guide cup). The design must preclude contact with housing parts.	Verification with CAD images

4.2.7 Housing influence on the derating		
Description	Requirement	Procedure/Notes
Visual inspection	Determining a target state	DIN EN 60512-1-1 characteristics 3a, 3b, 3d to 3g
Current excess temperature	Current excess temperature with housing The contacts measured for which the maximum temperature influence, e.g. due to adjacent cavities is to be expected. specification: limiting temperature of the system to be validated. "contact resistance specified test current method" see appendix A as appendix A.1 resistance measurement 2	DIN EN 60512-5-1 DIN EN 60512-2-2, measurement: 4.1
Derating (current carrying capacity)	Derating with housings current excess temperature: Loading with current, which must be increased incrementally and measurement of the current excess temperature. note: The limit temperature of the derating diagram is documented with the test group "Electrical stress test" once for each substance surface combination of the contact system.	DIN 60512-5-2
Visual inspection	Determine deviations from a target state	DIN EN 60512-1-1 characteristics 3a, 3b, 3d to 3g

Note:

Batch size: per 3 equipped housings (incl. counterpart equipped)
 Contact parts: case by case
 the surface must be documented.
 Line length: according DIN 60512-5-2
 Line cross-section: to be determined on a case-by-case basis or see customer drawing, in each case the same cross-section in a test object.

Requirement:

The measured values must correspond to the manufacturer`s specification.
 The following must be marked in the derating diagram:
 - the indication "derating in the housing" must be contained. the housing must be described (including number of pins)
 - the 80% characteristic curve of the measured values must be represented in the diagram

4.2.8 Vibration		
Description	Requirement	Procedure/Notes
Visual inspection	Determining a target state	DIN EN 60512-1-1 characteristics 3a, 3b, 3d to 3g
Contact resistance	Test voltage on ≤ 20 mV direct voltage (DC), Test time: 60s Contact resistance data: see appendix A as appendix A.1 resistance measurement 1	DIN EN 60512-2-1, "millivolt level method" measurement: 4.1
Contact resistance continuous	Contact resistance continuous during „Dynamic load, sinusoidal“ with test current (100mA) Measurement frequency: 1 measured value per min see appendix A.1 resistance measurement 2	
Dynamic load, sinusoidal	Severity: see appendix B Sweep speed: 1 oct/min	DIN EN 60068-2-6
Contact resistance continuous	Contact resistance continuous during „dynamic load, broadband random vibration“ with test current (100mA) Measurement frequency: 1 measured value per min see appendix A.1 resistance measurement 2	
Dynamic load, Broad-band random vibration	Severity: see appendix B	DIN EN 60068-2-64
Note: Dynamic load, sinusoidal and Dynamic load, broadband random vibration can also be performed simultaneously (SOR).		
Contact resistance	Test voltage on ≤ 20 mV direct voltage (DC), Test time: 60s Contact resistance data: see appendix A as appendix A.1 resistance measurement 1	DIN EN 60512-2-1, "millivolt level method" measurement: 4.1
Permanent shocks	severity: see appendix B	DIN EN 60068-2-27
Resonance frequency of contact assembly	Determination of the resonance frequency of the housing parts including contacts and lines under sinusoidal vibration. Vibration transducers of the smallest dimensions must be affixed to the housing, which is not screwed fast to the vibrator table. Dynamic load, sinusoidal Sweep speed: 1 oct/min $a = 10 \text{ m/s}^2$ $F = 5 \text{ Hz} - 2000 \text{ Hz} - 5 \text{ Hz}$ The vibration responses of the housing must also be recorded and documented as a diagram together with the excitation profile in the test report.	DIN EN 60068-2-6



Visual inspection	Determine deviations from a target state	DIN EN 60512-1-1 characteristics 3a, 3b, 3d to 3g
<p>Note:</p> <p>Batch size: at least 10 contact parts, distributed on at least 2 housings (incl. counterpart equipped)</p> <p>Contact parts: surface Ag (=silver-plated)</p> <p>Line cross-section: to be determined on a case-by-case basis</p> <p>Lines: the insulation must be withstand the test temperature, line types must be documented.</p> <p>The contact resistance (see resistance limits: see appendix A) is measured before and after each spatial axis in the clamped and firmly wired state (before it is converted to a new axis). In order to document the freedom from resonance of the clamping device, a resonance analysis must be performed in the designated frequency range before the start of the vibration test (load: 1g); this is not a component test but rather an examination of the test setup.</p> <p>The test specimen mounted on the vibration generator according see appendix C. For especially critical installation conditions, special agreements must be made between the manufacturer and user, and these must also be documented in the test report.</p> <p>requirement:</p> <p>The maximum values of appendix A must not be exceeded.</p> <p>There must be no mechanical damage to the housings and contacts that could impair their function, during and after the test. The plug connection must not open during the test.</p> <p>Circuit interruption monitoring takes place during the test. Permissible circuit < 1000 ns The circuit is considered interrupted when the contact resistance exceeds 7 Ω. Interruptions are not permissible.</p>		

4.3 Environmental requirements		
4.3.1 Climate load of the housing		
Description	Requirement	Procedure/Notes
Visual inspection	Determining a Target State	DIN EN 60512-1-1 characteristics 3a, 3b, 3d to 3g
Insulation resistance	Direct voltage (DC) from 500V ±50V Test time: 60s Insulation resistance: >100 MΩ	DIN EN 60512-3-1 connection type: A
Aging in dry heat	Duration: 120 h Temperature: 130 °C	DIN EN 60068-2-2 Test Bb
Humid heat, constant	Duration: 10 days, Temperature: 40 °C, Relative Humidity: 95 % After conclusion of test "Humid heat, constant", the insulation must be measured at the earliest after 30 min and at the latest after 60 min.	DIN EN 60068-2-30
Insulation resistance	Direct voltage (DC) from 500V ±50V Test time: 60s Insulation resistance: >100 MΩ	DIN EN 60512-3-1 connection type: A
Visual inspection	Determine deviations from a target state	DIN EN 60512-1-1 characteristics 3a, 3b, 3d to 3g
Low-temperature aging	Duration: 48 h Temperature: -40 °C	DIN EN 60068-2-1
Removal and insertion	Removal and insertion at -20 °C	-
Visual inspection	Determine deviations from a target state	DIN EN 60512-1-1 characteristics 3a, 3b, 3d to 3g
Aging in dry heat	Duration: 48h, Temperature: 80°C	DIN EN 60068-2-2 Test Bb
Drop test	Drop test in unplugged status	DIN EN 60068-2-31
Visual inspection	Determine deviations from a target state	DIN EN 60512-1-1 characteristics 3a, 3b, 3d to 3g



Note:	
Batch size:	5 housings, up to 5-pin fully equipped; for 6-pin and above, with 5 contacts
Contact parts:	any type
Housings:	all variants that occur (keying, colour optional)
Line cross-section:	to be determined on a case-by-case basis
Lines:	the insulation must be withstand the test temperature, line types must be documented.
requirement:	
After completion of the test, no function deviations must have occurred.	
It must be possible to open and re-close the connector even at -20°C.	
Any film hinges and latch elements present must not break off or crack upon actuation.	
The drop test must cause no damage to the specimens impairing their function. Locks must not open.	

4.3.2 Long-term temperature aging		
Description	Requirement	Procedure/Notes
Visual inspection	Determining a target state	DIN EN 60512-1-1 characteristics 3a, 3b, 3d to 3g
Contact resistance	Group 2 only Test voltage on ≤ 20 mV direct voltage (DC), Test time: 60s Contact resistance data: see appendix A as appendix A.1 resistance measurement 1	DIN EN 60512-2-1, "millivolt level method" measurement: 4.1
Long-term aging in dry heat	Group 1 & group 2 Duration: 1000 h Temperature: 130 °C Subsequent aging: 48 h at room temperature	DIN EN 60068-2-2 Test Bb
Contact resistance	Group 2 only Test voltage on ≤ 20 mV direct voltage (DC), Test time: 60s Contact resistance data: see appendix A as appendix A.1 resistance measurement 1	DIN EN 60512-2-1, "millivolt level method" measurement: 4.1
Functional test	Group 1 & group 2 Connection of the connector housings until complete latching. Opening of the lock and complete disconnection of the connector housings. Number of cycles: 5	-
Drop test	Drop test, group 1 only	DIN EN 60068-2-31



Contact removal force from the housing	<p>Group 2 only Contact pull-out force from the housing</p> <p>Values see point 2.3 retention force of contacts.</p> <p>The values for the secondary locks from “insert and retention forces of the contact parts in the housing” applies as the limit, even if the primary and secondary locks are closed here.</p>	testing speed: 50 mm/min
Visual inspection	Determine deviations from a target state	DIN EN 60512-1-1 characteristics 3a, 3b, 3d to 3g
<p>Note:</p> <p>Batch size: 2 groups, 5 housings per group Group 1: 5 housings unequipped Group 2: 5 housings equipped (incl. counterpart fully equipped); for 6-pin and above, with 5 contacts Contact parts: the surface must be determined on a case-by-case basis, however, at least 10 contact pairs for through resistance measurements. Lines: the insulation must be withstand the test temperature, line types must be documented. Line cross-section: to be determined on a case-by-case basis or see customer drawing, in each case the same cross-section in a test object</p> <p>Requirement:</p> <p>After completion of the test, there must be no functional impairments detected on the housings. Cracking or delamination’s that affects the function is not permissible. Unless otherwise specified in the processing specification.</p>		

4.3.3 Chemical resistance		
Description	Requirement	Procedure/Notes
Visual inspection	Determining a target state	DIN EN 60512-1-1 characteristics 3a, 3b, 3d to 3g
Insulation resistance	Direct voltage (DC) from 500V ±50V Test time: 60s Insulation resistance: >100 MΩ	DIN EN 60512-3-1 connection type: A
resistance to agents	The test object must be exposed to the fluids and aged for 48 h at the required aging temperature. Test fluid, see appendix E	
Insulation resistance	Direct voltage (DC) from 500V ±50V Test time: 60s Insulation resistance: >100 MΩ	DIN EN 60512-3-1 connection type: A
Visual inspection	Determine deviations from a target state	DIN EN 60512-1-1 characteristics 3a, 3b, 3d to 3g



<p>Note: Batch size: 2 housings equipped, sealed housings + 1 housing with blind seal, per test fluid Contact parts: any type</p> <p>Requirement: No functionally significant structural or dimensional change Insulation resistance: >100 MΩ The test object must remain fully functional.</p>
--

4.3.4 Water leak tightness		
Description	Requirement	Procedure/Notes
Visual inspection	All groups Determining a target state	DIN EN 60512-1-1 characteristics 3a, 3b, 3d to 3g
Aging in dry heat	All groups Duration: 120 h Temperature: 130 °C	DIN EN 60068-2-2 Test Bb
Temperature shock	All groups Duration: 144 cycles Temperature: - 40 °C / 130 °C 15 min respectively Acclimatization period: max. 10 s	DIN EN 60068-2-14 Test Na
Visual inspection	All groups	DIN EN 60512-1-1 characteristics 3a, 3b, 3d to 3g
Immersion with pressure difference	All groups are pressurized using suitable means. The remaining contact cavities are closed using blind plugs or sealed line ends. The specified holding times apply once the required pressure values (a-d) are maintained. Medium: low surface-tension, 5% NaCl solution a) Normal pressure b) -10 kPa, holding time 5 min c) -50 kPa, holding time 5 min d) Normal pressure change in pressure: 10 kPa/min	DIN EN 60512-14-5 DIN EN 60068-2-13



Line movement during immersion with pressure difference-vacuum	<p>Group 2: For housing with cover caps, the test must be performed without the cover caps. For housings that cannot be installed without cover caps (e.g. for insertion and removal aids), this test section is omitted. Definition of line movement: - no fixed clamping of the lines, no tension on the lines - movement profile: - deflection of the line bundle by 100 mm (final position) at 100 mm distance from the single-wire seal - hold for 10 s - deflection until the opposite final position - hold for 10 s - The movement profile is performed once per pressure stage during the pressure loading. - movement direction: perpendicular to the cable routing separation direction, in both spatial axes</p>	
Visual inspection	All group	DIN EN 60512-1-1 characteristics 3a, 3b, 3d to 3g
Temperature shock	<p>All groups Medium: low surface-tension, 5% NaCl solution Air temperature: 120 °C duration: 30 min each Water temperature: 0 °C duration: 15 min each Number of cycles: 5</p>	DIN EN 60068-2-14 Test Na
Degree of protection / pressure washer test	<p>All groups Severity: IP X9K All three sides of the DUT must be exposed to the steam jet. Test can be performed with cover caps. Test duration, per site: 15 s Distance, nozzle-DUT: 100-150 mm Pressure: 80 bar Temperature: 80 °C</p> <p>The test is performed 3 times.</p>	DIN EN 60529
Insulation resistance	<p>Direct voltage (DC) from 500V ±50V Test time: 60s Insulation resistance: >100 MΩ</p>	DIN EN 60512-3-1 connection type: A
Visual inspection	Determine deviations from a target state	DIN EN 60512-1-1 characteristics 3a, 3b, 3d to 3g

Note:

Batch size: 2 Groups
 Group 1: 2 housings equipped with blind plugs (incl. counterpart fully equipped);
 Group 2: 5 housings equipped (incl. counterpart fully equipped) with contacts
 Contact parts: case-by-case
 Lines: the insulation must be withstand the test temperature, line types must be documented.
 Line cross-section: to be determined on a case-by-case basis or see customer drawing, in each case the same cross-section in a test object

Requirement:

No medium must penetrate the connector, possible use of water finding paste.
 The Insulation resistance must be >100 MΩ.
 The function of the locking and releasing elements must be remain fully intact.

4.3.5 Locking noise		
Description	Requirement	Procedure/Notes
Visual inspection	Determining a target state	DIN EN 60512-1-1 characteristics 3a, 3b, 3d to 3g
Aging	Aging, 24 h at RT	
Locking noise	Distance to measuring microphone: 600mm ±50mm Actuation of the lock: by hand, with the least possible contact Avoidance of falsifying reflections by underlying structures (table) or near walls, see appendix F	
Visual inspection	Determine deviations from a target state	DIN EN 60512-1-1 characteristics 3a, 3b, 3d to 3g

Note:
 Batch size: 2 housings per mould cavity (equipped)

Requirement:
 Aim: all locks to be actuated in vehicle assembly must produce an audible locking feedback

The measured dB(A) values must be documented.
 For this purpose, the signal-to-noise ratio between the locking noise and ambient noise must be at least 7 dB(A).
 The locking noise must be at least $L_{Apeak} \geq 70$ dB(A).
 L_{Apeak} : peak level of the sound level with frequency weighting A



4.3.6 Retention force of the blind plugs		
Description	Requirement	Procedure/Notes
Theoretical determination of the internal pressure p_0	Determination of the air volumes in the interior of the contact assembly housing in the closed state and in the state when the housing seal touches the mating piece for the first time. With the two volumes, the maximum internal pressure p_0 that occurs can be computed.	
Visual inspection	Determine deviations from a target state	DIN EN 60512-1-1 characteristics 3a, 3b, 3d to 3g
Long-term aging in dry heat	Duration: 2 h Temperature: 60 °C	DIN EN 60068-2-2 Test Bb
Determination of the retention force of the blind plugs p_{max}	Continuously increase the pressure difference between closed and locked contacts assembly with respect to the external environment (0.5 bar/min) until at least one blind plug slides out ($=p_{max}$). The internal pressure can be increased or the external pressure lowered. Requirement: $p_{max} > 1,5 * p_0$	
<p>Note: Batch size: 3 fully equipped, sealed housings, but at least 10 bling plugs</p> <p>Requirement: Aim: Assurance of the retention force of the blind plugs in relation to the internal pressure of the sealed contact assembly in the contacting process.</p> <p>If it is ensured that the possible internal pressure is max. 0.5 bar, the test can be replaced by a positive pressure test at " Immersion with pressure difference ", see 4.3.4</p>		

5. Appendixes

5.1 Appendix A insulation resistance (in mΩ)

Maximum contact resistance limits in mΩ at room temperature after aging.

The values include: Contact resistance + 2*Crimp resistance, measured according to DIN EN 60512-2-1.

Cables according to LV 112 (Line test regulation, low voltage cable).

Conductivity Contact material >20% IACS, correction factor at lower conductivity acc. to DIN EN 60352-2.

valid for all surfaces e. g. Au, Ag, Sn

conductor cross-section in mm ²	0,13	0,22	0,35	0,50	0,75	1,0
mΩ	20	20	15	15	15	15

5.2 Appendix A.1 determination of the contact resistance

The contact resistance is always measured according to the 4-point measuring method.

At each measuring point (e. g. contact) the cable (each approx. 100mm line) is measured at both ends of the contacts. The line length is to be calculated from the resistance measurements, i. e. reference line of the corresponding line length is also measured)

The adjusted resistance values are documented in mΩ and the value of the reference line. These are calculated from the voltage drop and the measured current.

There are 2 types of contact resistance measurement:

Contact resistance 1

measurement according to "millivolt level method" according to DIN EN 60512-2-1

use for before/after determination of resistance

conditional short-circuit current max. 100 mA

clamping voltage max. 20 mV in no-load operation (direct current/ DC)

Contact resistance 2

measurement according to "Measurement with specified current" according to DIN EN 60512-2-2

It is used for the loading of the contact with currents, which extend from the mA-range to wide into the power range.

The current is prescribed in the corresponding test Groups.

Heating of the contact at different currents, then the temperature is measured, e. g. current over-temperature curve.

Measurement Voltage drop as a function of current Clamping voltage max. 20 mV in no-load mode (direct current/ DC).

measured variables: voltage drop, temperature

documentation: temperature, Resistance

5.3 Appendix B severity

severity	temperature cycle(=TC)	random vibration with TC	sine wave with TC	number of shocks
2. „body-sealed“	0 min / 20°C 60 min / -40°C 150 min / -40°C 300 min / 120°C 420 min / 120°C 480 min / 20°C	20 h per axis RMS value of acceleration 27,8 m/s ² Hz (m/s ²) ² /Hz 10 20 55 6,5 180 0,25 300 0,25 360 0,14 1000 0,14	no Sine wave	A = 30 g T = 6ms half-wave sinusoidal number of shocks: 6000

severity	temperature cycle(=TC)	random vibration with TC	sine wave with TC	number of shocks
3. „applications close to power-train“	0 min / 20°C 60 min / -40°C 90 min / -40°C 240 min / 120°C 420 min / 120°C 480 min / 20°C	22 h per axis RMS value of acceleration 105,5 m/s ² Hz (m/s ²) ² /Hz 20 10 95 10 110 0,01 380 0,01 410 20 800 10 1500 5	22 h per axis Hz mm 100 0,095 Hz m/s ² 200 150 220 150 221 100 400 100	

severity	temperature cycle(=TC)	random vibration with TC	sine wave with TC	number of shocks
4. „engine mounted parts“ appendix C vibrator table mounting	0 min / 20°C 60 min / -40°C 90 min / -40°C 240 min / 140°C 420 min / 140°C 480 min / 20°C	22 h je axis RMS value of acceleration 181 m/s ² Hz (m/s ²) ² /Hz 10 10 100 10 300 0,51 500 20 2000 20	22 h per axis Hz m/s ² 100 100 150 150 200 200 240 200 255 150 440 150	

5.4 Appendix C vibrator table mounting

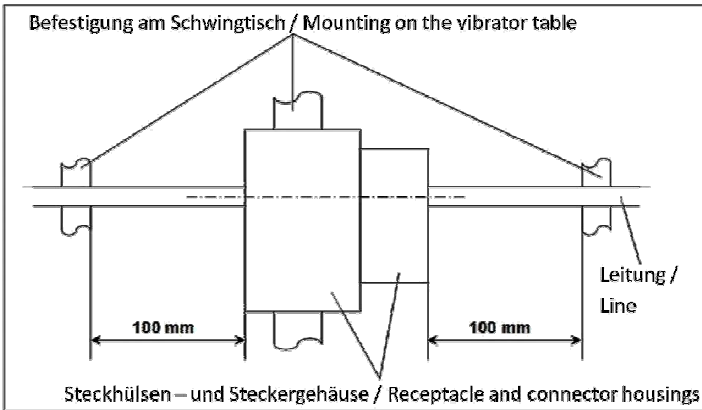

Fig.1
mounting on the vibrator table, coupling

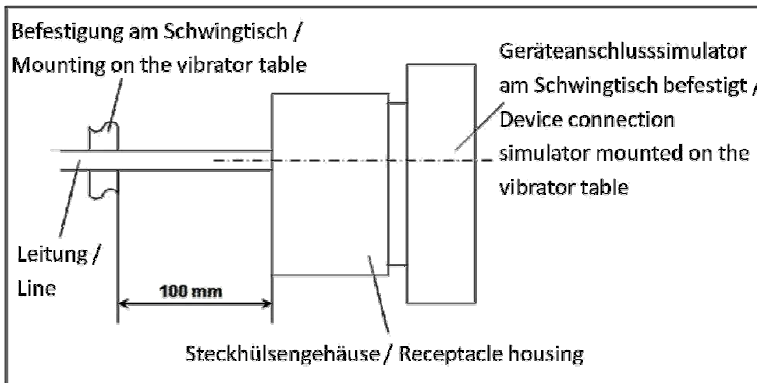

Fig.2
mounting on the vibrator table, device connection

5.5 Appendix D drop test in drum

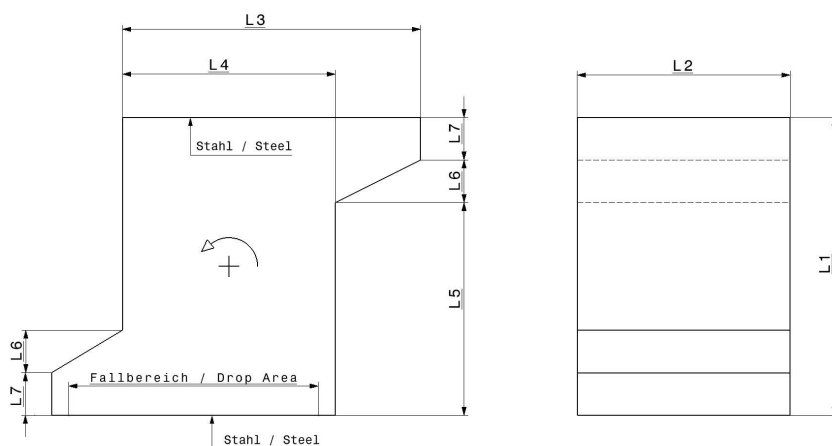

Fig.3 drop test in drum

L1= 1200 mm, L2/L4= 500 mm, L3= 700 mm, L5= 1000 mm, , L6/L7=100 mm

5.6 Appendix E media list

min. 100 ml , according to DIN EN ISO 175
dousingmind. 8 ml/cm² surface

chemical agent	description	dousing	aging temperature °C
			48 h
brake fluid	DOT 4 / DOT 5	x	50
FAM test fuel (gasoline/premium)	commercially available	x	RT
diesel	DIN EN 590	x	RT
biodiesel	DIN EN 14214	x	RT
diesel additive AdBlue	DIN 70070	x	RT
engine oil 5W-30	fully synthetic	x	50
power steering fluid	according to requirement	x	50
automatic transmission fluid	fully synthetic	x	50
radiator antifreeze	stable to -40°C	x	50
road salt solution	salt mixture (nordic country salt): 3%-salt solution, which of 95% NaCl, 2,5% MgCl ₂ and 2,5% CaCl ₂	x	50

5.7 Appendix F schematic of the measurement setup “volume measurement”

Messraum mit "Freifeldbedingungen"
measuring room with "free-field conditions"

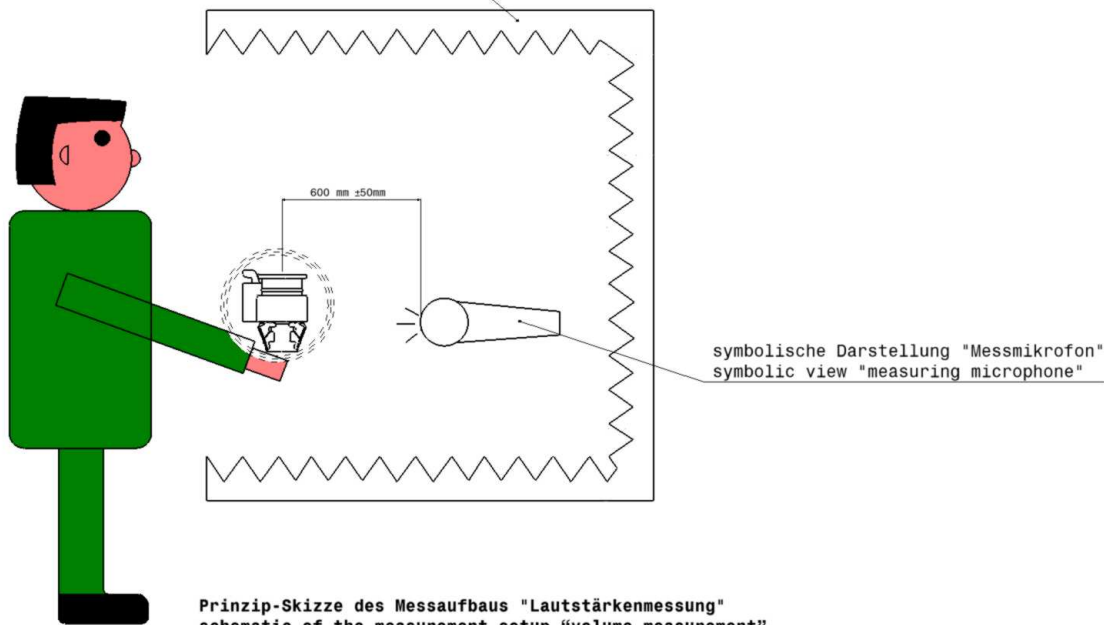

6. Performed test matrix

Not all the above approval tests have been carried out for all numbers of poles!

6.1 1.2 SealStar M Connector

Test		numbers of terminal cavities			
		2	3	4	8
4.1.1	Dimensional inspection	X	X	X	X
4.1.2	Electrical requirements	X	X	X	X
4.2.1	Material- and surface analyse	X	X	X	X
4.2.2	Contact engagement length	X	X	X	X
4.2.3	Interaction between contact and housing	X	X	X	X
4.2.4	Handling and functional reliability of the housing	X	X	X	X
4.2.5	Insert and retention forces of the contact parts in the housing	X	X	X	X
4.2.6	Scoop-proofing				
4.2.7	Housing influence on the Derating	X	X	X	X
4.2.8	Vibration (Severity = S)	S 4	S 4	S 4	S 4
4.3.1	Climate load of the housing	X	X	X	X
4.3.2	Long-term temperature aging	X	X	X	X
4.3.3	Chemical resistance	X	X	X	X
4.3.4	Water leak tightness	X	X	X	X
4.3.5	Locking noise	X	X	X	X
4.3.6	Retention force of the bling plugs	X	X	X	X

7. Revision table

Revision	Alteration	Editor
00	First edition	Außerer N.