

-Hirschmann Nr.
vertieft
HIRSCHMANN NO.
RECESSED

-Formteilnummer
vertieft
MOLD CAVITY NO.
RECESSED

-Materialkennzeichnung
vertieft
MATERIAL DESCRIPTION
RECESSED

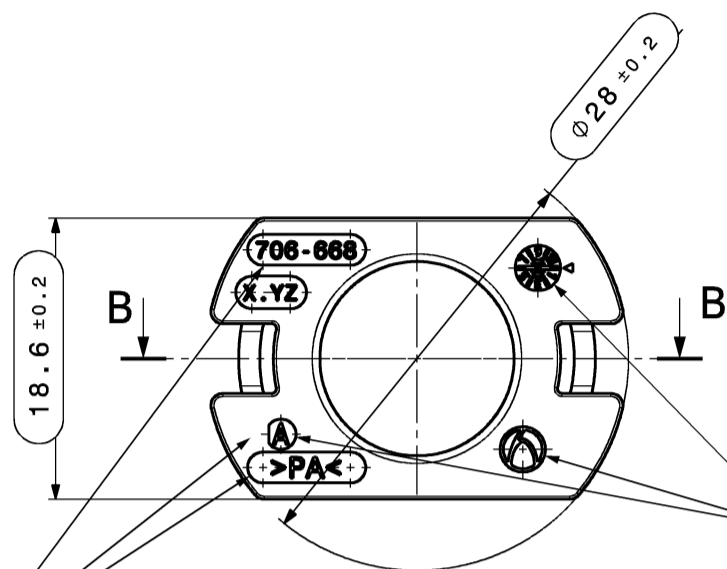

-Datum D3
vertieft
DATE D3
RECESSED

-HA Revision
HA REVISION

-Firmenzeichen
vertieft
COMPANY SIGN
RECESSED

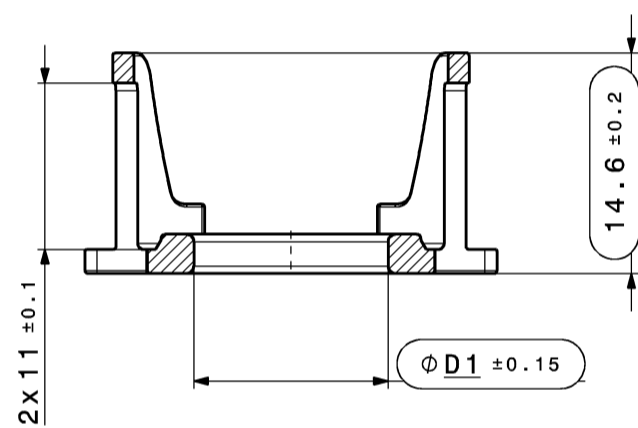
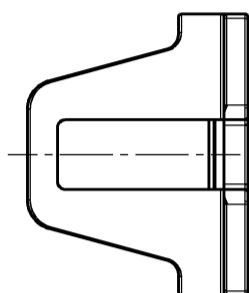

Schnittansicht B-B
CUT SECTION B-B

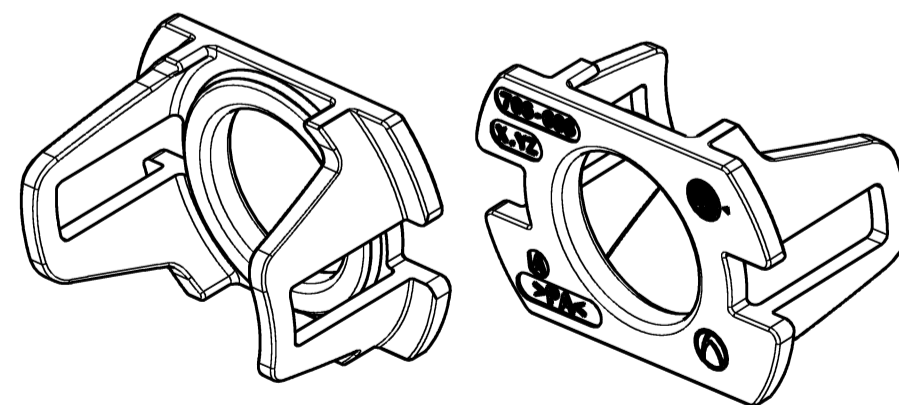

Isometrische Ansicht
ISOMETRIC VIEW

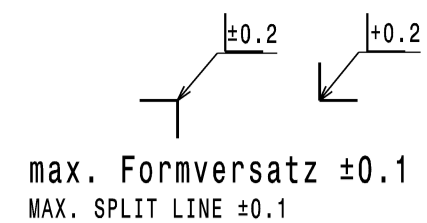

max. Formversatz ±0.1
MAX. SPLIT LINE ±0.1

Toleranzen fuer nicht tolerierte Masse:

- Winkelmasse: (in °)
Fuer alle Winkelmasse gilt ±2°
- Radien: (in mm)
- Laengenmasse:
DIN 2768-mH
- Allgemeintoleranz fuer Symmetrie: ±0.2

bis 1	1-3	3-10	10-20	20-30	30-50
±0.2	±0.3	±0.4	±0.5	±1	±2

TOLERANCES FOR UNTOLERATED DIMENSIONS:

- ANGLE-DIMENSIONS (IN °)
TOLERANCE FOR ALL ANGLE-DIMENSIONS: ±2°
- RADII: (IN mm)
- DISTANCE-DIMENSIONS:
DIN 2768-mH
- GENERAL TOLERANCE FOR SYMMETRY: ±0.2

TO 1	1-3	3-10	10-20	20-30	30-50
±0.2	±0.3	±0.4	±0.5	±1	±2

Bemerkungen:

COMMENTS:

- massgebend ist der deutsche Text / GERMAN TEXT IS VALID
- unbemasste Radien R0.3 +/- 0.1mm / UNDIMENSIONED RADII R0.3 +/-0.1mm
- Funktionsbestimmende Maße, die mit gekennzeichnet sind, werden im EMPB dokumentiert. Nicht gekennzeichnete Maße werde ebenfalls ausgemessen, aber nicht im EMPB dokumentiert. Abweichungen sind zu korrigieren. DIMENSIONS WITH ARE DOCUMENTED IN THE INITIAL SAMPLE INSPECTION PREORT (ISIR). UNMARKED DIMENSIONS ARE ALSO MEASURED BUT NOT DOCUMENTED IN THE ISIR. VARIATIONS MUST BE CORRECTED.
- Teil entspricht Altautorichtlinie nach DBL 8585
PART CORRESPONDS TO SCRAP CAR GUIDELINE DBL 8585
- Teilekennzeichnung angelehnt an MBN 10435
PART IDENTIFICATION SIMILAR MBN 10435
- Max. 30% Regranulat zulaessig / MAX. 30% RECLAIM ACCEPTABLE

This materials contain information protected by copyright. No part of this materials may be photocopied, otherwise reproduced or translated into another language without the prior written consent of Hirschmann. All rights reserved.

706-668-503	12,85	PA66 GF30	rot / RED ~ RAL 3024	1,3g	A	6mm ²
706-668-502	11,35		grau / GREY ~ RAL 7040	1,4g	A	4mm ²
706-668-501	9,95		beige / FAWN ~ RAL 1001	1,5g	A	2,5mm ²
Lft. Bestell Nr. ORDER NO.	D1	Material MATERIAL	Farbe COLOUR	Gewicht WEIGHT	HA REV.	Leitungsquerschnitt WIRE CROSS SECTION

01 00	changed material to PA66 GF30 Ersterstellung / Initial edition	14.07.2021 30.07.2018	WRI RHO	
Version	Numb. of	Description of alteration	Date	drwn
Test instructions				
Crude state	Material	Final state	Gross weight	g/pc
			Final weight	g/pc
Material-No.	Tolerances	EN ISO 8015	Surface	cm ² /pc
Edges		DIN ISO 13715	dimensions	Scale
Geometric tolerances		DIN ISO 1101	in millimeters	2:1
Date	Name	Dimensions specially checked for acceptance		
Drawn	14.07.2021	W.Ribitsch	Title	
Checked	14.07.2021	L.Breuss	HPS Verteiler Kappe	
Released	14.07.2021	L.Breuss	Type	CDI
HIRSCHMANN AUTOMOTIVE		Drawing - No. 706-668-...00		Sheet of 1
Oberer Paspelweg 6-8 A-6830 Rankweil-Brederis		Origin	Replacement	DNR 100000257949

Index 501

-Hirschmann Nr.
vertieft
HIRSCHMANN NO.
RECESSED

-Formteilnummer
vertieft
MOLD CAVITY NO.
RECESSED

-Materialkennzeichnung
vertieft
MATERIAL DESCRIPTION
RECESSED

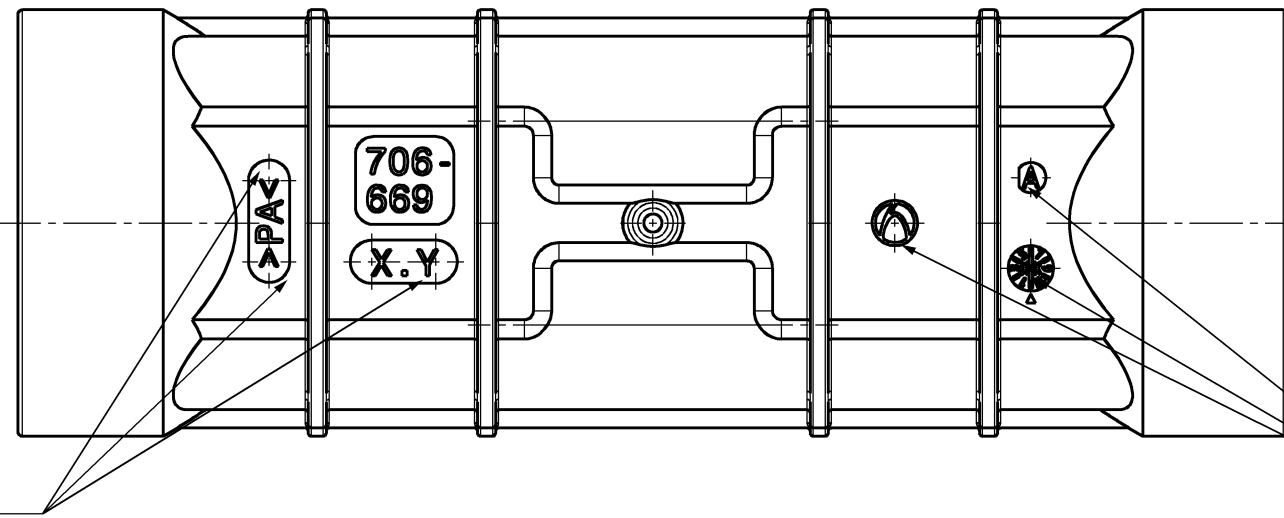

-Datum D3
vertieft
DATE D3
RECESSED

-HA Revision
HA REVISION

-Firmenzeichen
vertieft
COMPANY SIGN
RECESSED

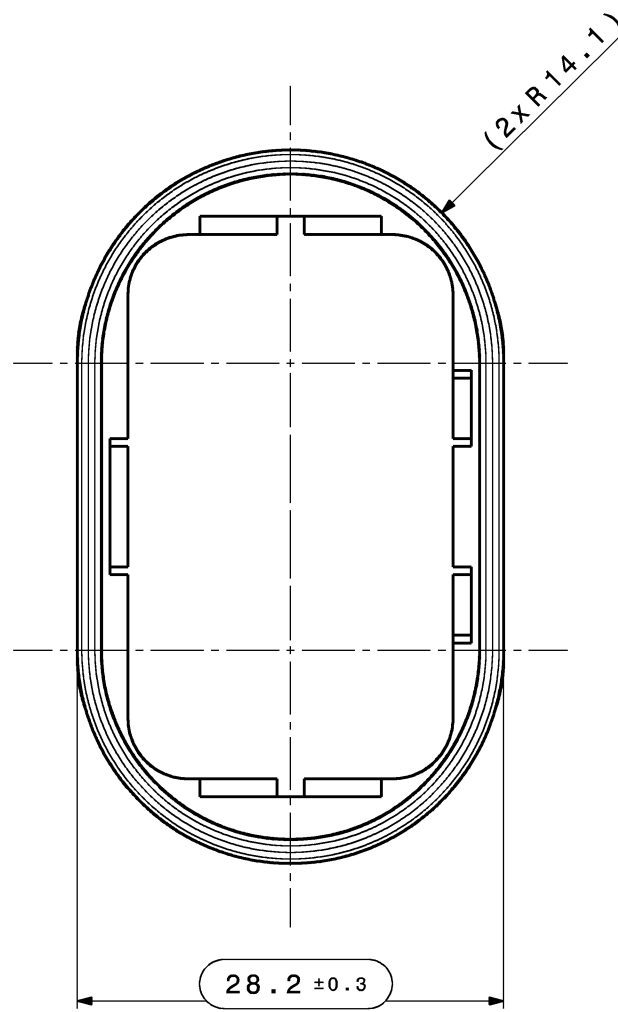
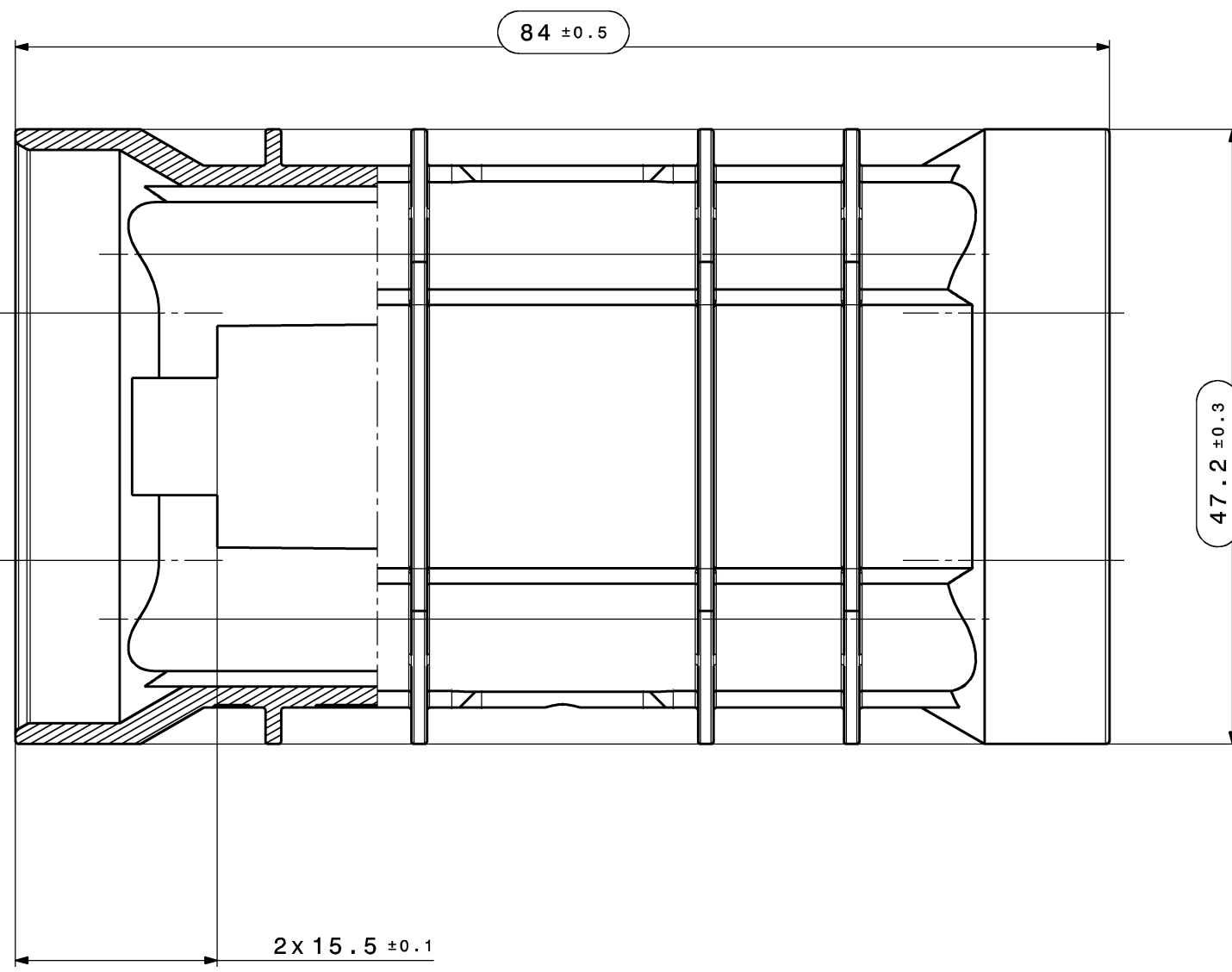

Index 502

Restliche Bemassungen und Beschriftungen siehe Index 501
REMAINING DIMENSIONS AND LETTERING SEE INDEX 501

2x Anreihenelemente siehe TE Zeichnung C-114-18063-2 Rev.B (10.03.2009)
ANREIHELEMENT - Passiv (Karosserie-seite)
Sonderausführung: reduzierte Bauhoehe
114-18063-2-bx-f
2x GUIDE PART PASSIVE SEE TE DRAWING C-114-18063-2 Rev.B (10.03.2009)
LOCATOR PART - PASSIVE (CARRIAGE SIDE)
SPECIAL VERSION: REDUCED HEIGHT
114-18063-2-bx-f

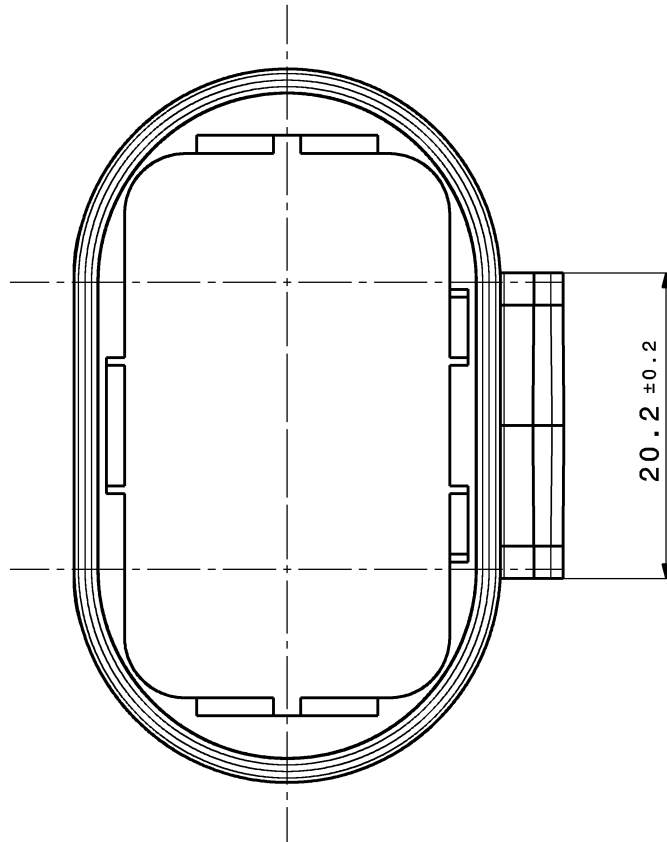
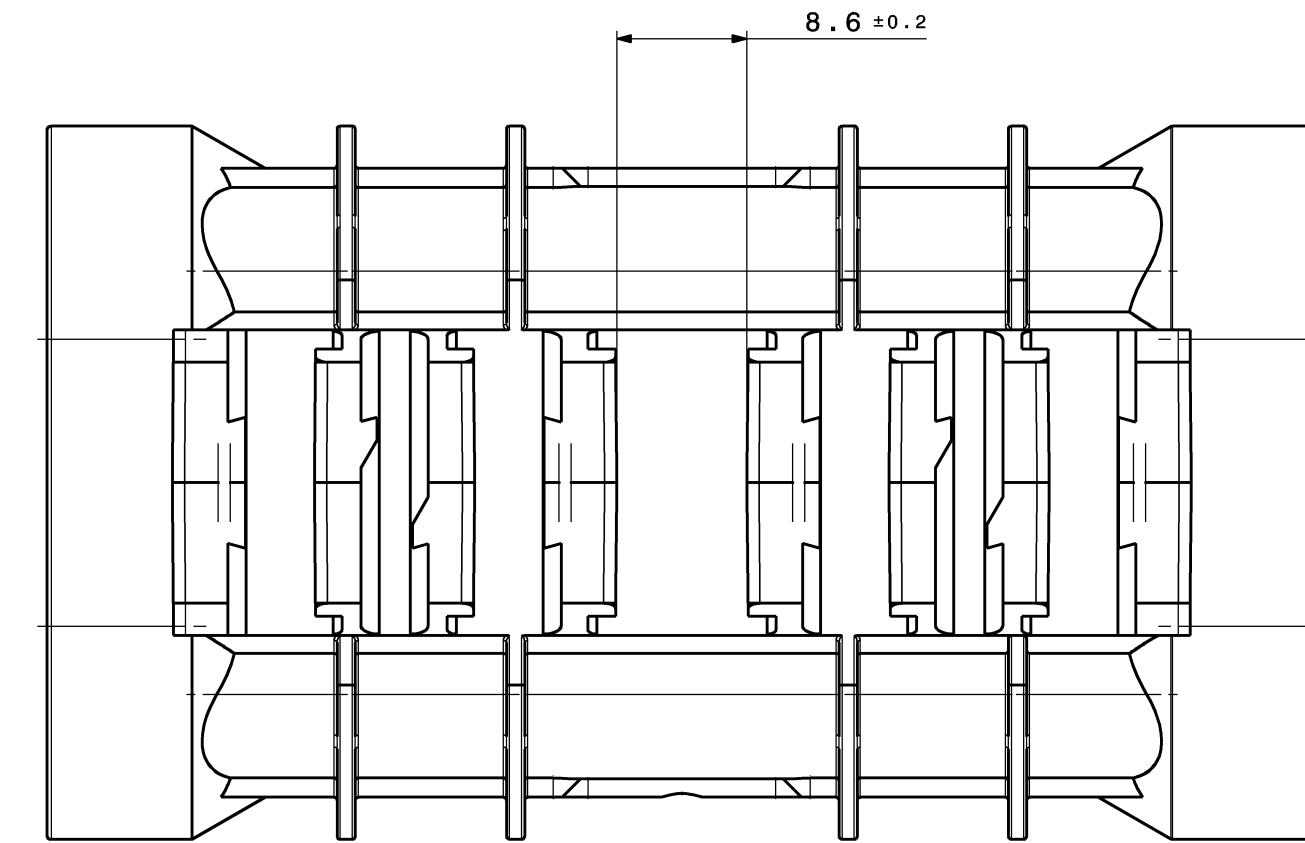
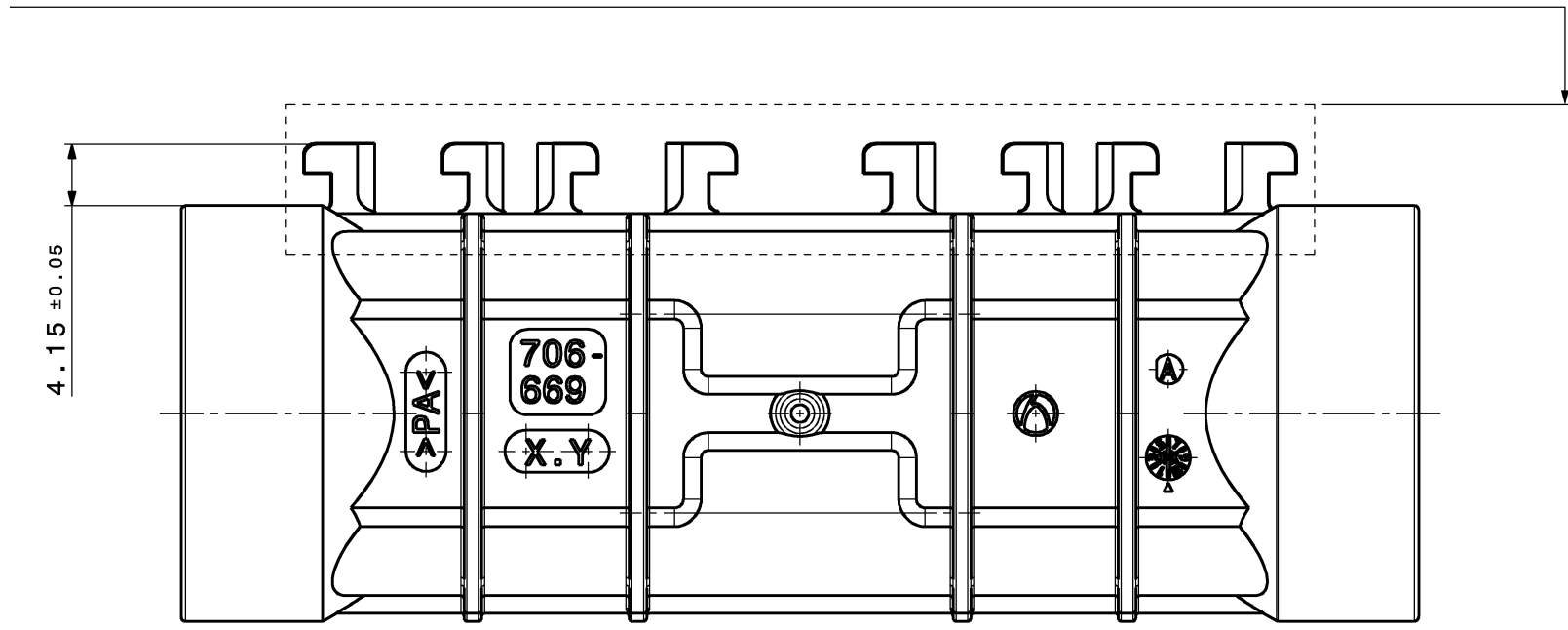

Toleranzen fuer nicht tolerierte Masse:

bis 1	1-3	3-10	10-20	20-30	30-50
±0.2	±0.3	±0.4	±0.5	±1	±2

TOLERANCES FOR UNTOLERATED DIMENSIONS:

TO 1	1-3	3-10	10-20	20-30	30-50
±0.2	±0.3	±0.4	±0.5	±1	±2

max. Formversatz ±0.1
MAX. SPLIT LINE ±0.1

Bemerkungen:

1. massgebend ist der deutsche Text / GERMAN TEXT IS VALID
2. unbemaste Radien R0.3 +/- 0.1mm / UNDIMENSIONED RADII R0.3 +/-0.1mm
3. Funktionsbestimmende Maße, die mit \square gekennzeichnet sind, werden im EMPB dokumentiert. Nicht gekennzeichnete Maße werden ebenfalls ausgemessen, aber nicht im EMPB dokumentiert. Abweichungen sind zu korrigieren. DIMENSIONS WITH \square ARE DOCUMENTED IN THE INITIAL SAMPLE INSPECTION PREORT (ISIR). UNMARKED DIMENSIONS ARE ALSO MEASURED BUT NOT DOCUMENTED IN THE ISIR. VARIATIONS MUST BE CORRECTED.
4. Teil entspricht Altautorichtlinie nach DBL 8585
PART CORRESPONDS TO SCRAP CAR GUIDELINE DBL 8585
5. Teilekennzeichnung angelehnt an MBN 10435
PART IDENTIFICATION SIMILAR MBN 10435
6. Max. 30% Regranulat zulaessig / MAX. 30% RECLAIM ACCEPTABLE

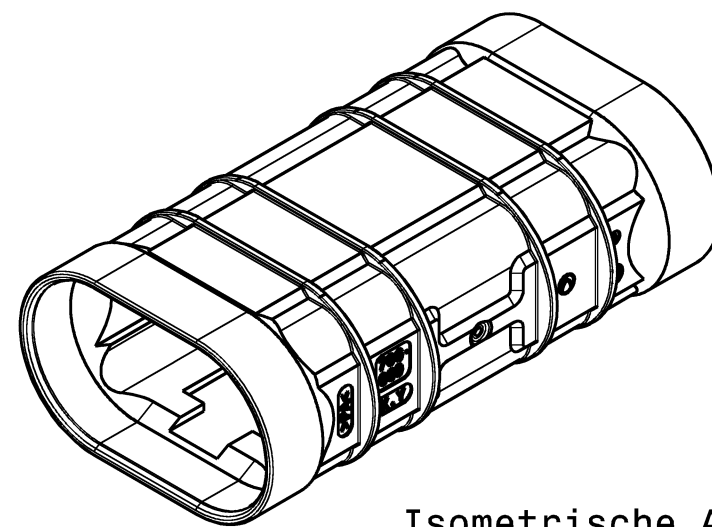

Isometrische Ansicht Index 501
Maßstab: 1:1
ISOMETRIC VIEW INDEX 501
SCALE: 1:1

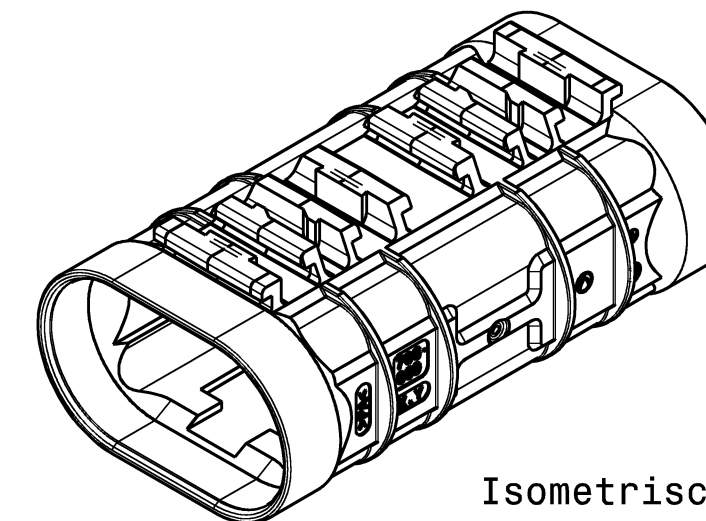

Isometrische Ansicht Index 502
Maßstab: 1:1
ISOMETRIC VIEW INDEX 502
SCALE: 1:1

706-669-502	PA GF35	orange	27,9g	A
706-669-501		~ RAL 2003	24,6g	A
Lft. Bestell Nr.	Material	Farbe	Gewicht	HA REV.
ORDER NO.	MATERIAL	COLOUR	WEIGHT	

01	ADDED INDEX 502	19.07.2019	RHO
00	Ersterstellung / Initial edition	31.07.2018	RHO
Aenderungsbearbeitung / description of alteration		date	gr. / dr. /
Pruefvorschriften / test instructions			
Material-Nr. / No.	Toleranzen / tolerances	Form- u. Lagetoleranzen / geometric tolerances	MASSSTAB / SCALE
	Werkstoffueckanten / edges	DIN ISO 13715	2:1
Masse werden bei Abnahme besonders geprueft / dimensions specially checked for acceptance			
Gezeichnet / drawn	19.07.2019	R. HOOP	Benennung / title
Geprueft / checked	30.07.2019	L. BREUSS	HPS Verteiler Schirmgehaeuse
Freigegeben / released	30.07.2019	L. BREUSS	Typ / type
HIRSCHMANN AUTOMOTIVE		08	Zeichnungs-Nr. / drawing - No.
A-680 Namwell-Druckerei			706-669-...00
Ersetzung / replacement		Blatt / sheet	
DWG		100000257992	

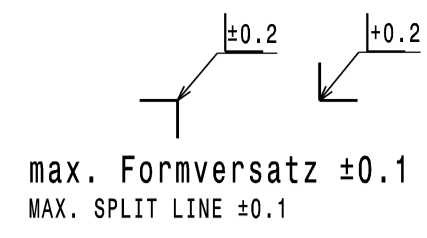

Toleranzen fuer nicht tolerierte Masse:

- Winkelmasse: (in °)
Fuer alle Winkelmasse gilt ±2°
- Radien: (in mm)
- Laengemasse:
DIN 2768-mH
- Allgemeintoleranz fuer Symmetrie: ±0.2

bis 1	1-3	3-10	10-20	20-30	30-50
±0.2	±0.3	±0.4	±0.5	±1	±2

TOLERANCES FOR UNTOLERATED DIMENSIONS:

- ANGLE-DIMENSIONS (IN °)
TOLERANCE FOR ALL ANGLE-DIMENSIONS: ±2°
- RADII: (IN mm)
- DISTANCE-DIMENSIONS:
DIN 2768-mH
- GENERAL TOLERANCE FOR SYMMETRY: ±0.2

TO 1	1-3	3-10	10-20	20-30	30-50
±0.2	±0.3	±0.4	±0.5	±1	±2

Bemerkungen:

COMMENTS:

- massgebend ist der deutsche Text / GERMAN TEXT IS VALID
- unbemasste Radien R0.3 +/- 0.1mm / UNDIMENSIONED RADII R0.3 +/-0.1mm
- Funktionsbestimmende Maße, die mit gekennzeichnet sind, werden im EMPB dokumentiert. Nicht gekennzeichnete Maße werde ebenfalls ausgemessen, aber nicht im EMPB dokumentiert. Abweichungen sind zu korrigieren. DIMENSIONS WITH ARE DOCUMENTED IN THE INITIAL SAMPLE INSPECTION PREORT (ISIR). UNMARKED DIMENSIONS ARE ALSO MEASURED BUT NOT DOCUMENTED IN THE ISIR. VARIATIONS MUST BE CORRECTED.
- Teil entspricht Altautorichtlinie nach DBL 8585
PART CORRESPONDS TO SCRAP CAR GUIDELINE DBL 8585
- Teilekennzeichnung angelehnt an MBN 10435
PART IDENTIFICATION SIMILAR MBN 10435

-Datum D3 vertieft
DATE D3 RECESSED

-HA Revision
HA REVISION

-Firmenzeichen vertieft
COMPANY SIGN RECESSED

-Hirschmann Nr. vertieft
HIRSCHMANN NO. RECESSED

-Formteilnummer vertieft
MOLD CAYITY NO. RECESSED

-Materialkennzeichnung vertieft
MATERIAL DESCRIPTION RECESSED

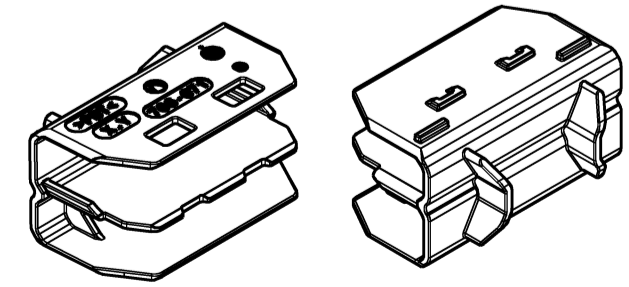
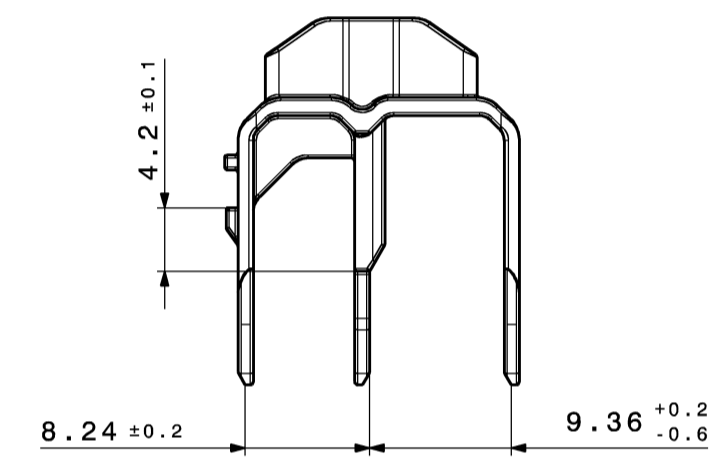
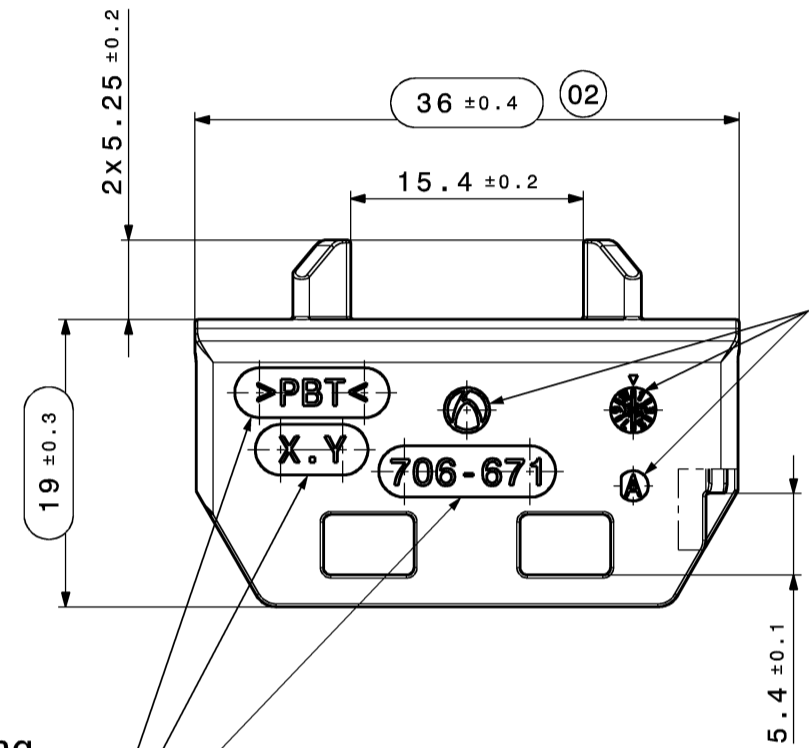

Isometrische Ansicht
Maßstab: 1:1
ISOMETRIC VIEW
SCALE: 1:1

706-671-502	PBT GF30	gruen / GREEN -RAL 6017	4g	B
706-671-501		gelb / YELLOW -RAL 1016	4g	B
Lft. Bestell Nr. ORDER NO.	Material MATERIAL	Farbe COLOUR	Gewicht WEIGHT	HA REV.

02	geometry elongated; HA revision changed to B;	23.04.2020	VGR	
01	Index 502 (green) added	14.06.2019	RHO	
00	Ersterstellung / Initial edition	31.07.2018	RHO	
Version	Numb. of	Description of alteration	Date	drwn
Test instructions				
Crude state	Material	Final state	Gross weight	g/pc
			Final weight	g/pc
Material-No.	Tolerances	EN ISO 8015	Surface	cm²/pc
Edges		DIN ISO 13715	dimensions	Scale
Geometric tolerances		DIN ISO 1101	in millimeters	2:1
Date	Name	Dimensions specially checked for acceptance		
Drawn	23.04.2020	V.Grobnicu	Title	DIN A2
Checked	23.04.2020	T.Kleiner	HPS Verteiler Isolator	
Released	23.04.2020	T.Kleiner	Type	CDI
HIRSCHMANN AUTOMOTIVE		Drawing - No. 706-671-...00		Sheet 1 of 1
Oberer Paspelweg 6-8 A-6830 Rankweil-Brederis		Origin	Replacement	DNR 100000258107

This materials contain information protected by copyright. No part of this materials may be photocopied, otherwise reproduced or translated into another language without the prior written consent of Hirschmann. All rights reserved.

Plot from: TNAITER on 12.10.2020 Doc.Vers. 02 Valid until: ... Status: Kundenfreigabe

Toleranzen fuer nicht tolerierte Masse:

- Winkelmasse: (in °)
Fuer alle Winkelmasse gilt ±2°
- Radien : (in mm)

bis 1	1-3	3-10	10-20	20-30	30-50
±0.2	±0.3	±0.4	±0.5	±1	±2

- Laengenmasse : DIN 2768-mH
- Allgemeintoleranz fuer Symmetrie: $\begin{matrix} \text{—} \\ \text{—} \\ \text{—} \end{matrix} 0.3$

TOLERANCES FOR UNTOLERATED DIMENSIONS:

- ANGLE-DEMENSIONS (IN °)
TOLERANCE FOR ALL ANGLE-DIMENSIONS: ±2°
- RADII : (IN mm)

TO 1	1-3	3-10	10-20	20-30	30-50
±0.2	±0.3	±0.4	±0.5	±1	±2

- DISTANCE-DIMENSIONS: DIN 2768-mH
- GENERAL TOLERANCE FOR SYMMETRY: $\begin{matrix} \text{—} \\ \text{—} \\ \text{—} \end{matrix} 0.3$

Quadr.-Nr. "01"- "..."
QUADR.-NO. "01"- "..."

Anspritzpunkt
INJECTION POINT

Nest-Nr. "1"- "..."
CAVITY NO. "1"- "..."

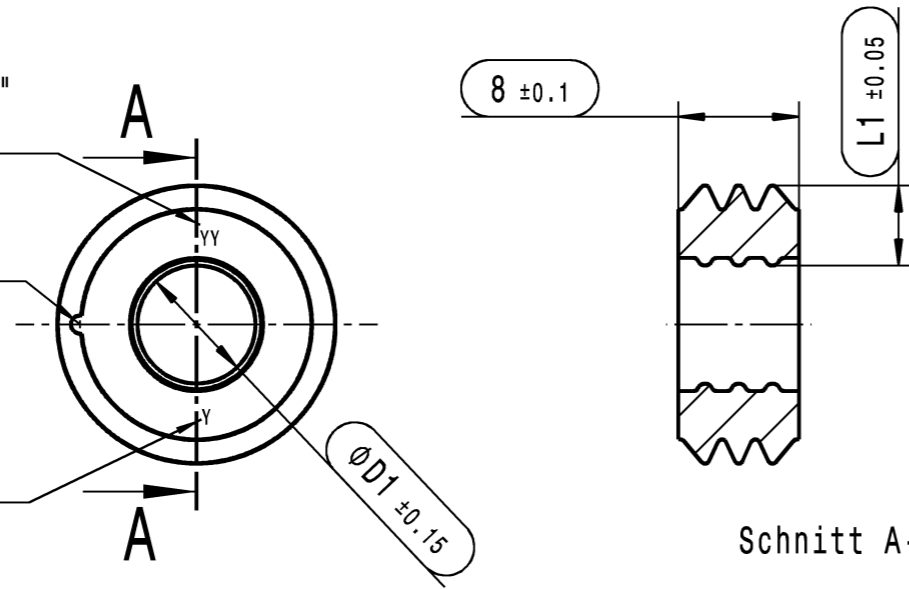

Schnitt A-A

Bemerkungen:

COMMENTS:

- massgebend ist der deutsche Text
GERMAN TEXT IS VALID
- Funktionsbestimmende Masse, die mit --- gekennzeichnet sind, werden im EMPB dokumentiert. Nicht gekennzeichnete Masse werden ebenfalls ausgemessen, aber nicht im EMPB dokumentiert. Abweichungen sind zu korrigieren.
DIMENSIONS MARKED WITH --- ARE DOCUMENTED IN THE INITIAL SAMPLE INSPECTION REPORT (ISIR). UNMARKED DIMENSIONS ARE ALSO MEASURED BUT NOT DOCUMENTED IN THE ISIR. VARIATIONS MUST BE CORRECTED.
- Teil entspricht Altautorichtlinie
PART CORRESPONDS TO SCRAP CAR GUIDLINE

709-113-517	6,7	6,25	LSR 50 Shore A	rot-orange RED-ORANGE	
709-113-516	10,7	3,7		rot-orange RED-ORANGE	
709-113-515	8,7	4,7		grau GREY	
709-113-514	7,3	5,4		beige BEIGE	
709-113-513	9,5	4,3		blau BLUE	
709-113-512	7,5	5,3		gelb YELLOW	
709-113-511	7,3	5,95		gruen GREEN	
709-113-506	10,7	3,7		rot-orange RED-ORANGE	
709-113-505	8,7	4,7		grau GREY	
709-113-504	7,3	5,4		beige BEIGE	
Erz. Nr. Index PART NUMBER	ØD1	L1		Material	Farbe COLOUR

06					09.02.2021	STS
05					23.07.2018	RHO
04					12.11.2013	RUM
03					01.02.2012	RUM
02					17.10.2011	MAM
01					26.09.2011	RUM
00					09.05.2011	MAM

Version	Numb. of	Description of alteration	Date	drwn
06		Added Index 504/505/506; Tabelle angepasst (Farben)	09.02.2021	STS
05		Indices ersetzt; Indices replaced;	23.07.2018	RHO
04		Index 007 hinzu;	12.11.2013	RUM
03		Maß bei Index 503 von 8,5 auf 9,5 geaendert;	01.02.2012	RUM
02		Englische uebersetzung hinzugefuegt;	17.10.2011	MAM
01		Ersterstellung / Initial edition	26.09.2011	RUM
00			09.05.2011	MAM

Test instructions			
Crude state	Material	Final state	Gross weight g/pc
			Final weight g/pc
Material-No.	Tolerances EN ISO 8015	Surface cm ² /pc	Scrap x
	Edges DIN ISO 13715	dimensions in millimeters	Scale 2:1
	Geometric tolerances DIN ISO 1101		
Drawn	Date 09.02.2021	Name S.Shaw	Title MANTELLEITUNGSDICHTUNG HV 2+2POL Type SEAL
Checked	Date 09.02.2021	Name L.Breuss	
Released	Date 09.02.2021	Name L.Breuss	
HIRSCHMANN AUTOMOTIVE		Drawing - No. 709-113-...00	Sheet 1 of 1
Oberer Paspelsweg 6-8 A-6830 Rankweil-Brederis			
Origin	Replacement		DNR 10000096422

This materials contain information protected by copyright. No part of this materials may be photocopied, otherwise reproduced or translated into another language without the prior written consent of Hirschmann. All rights reserved.

Plot from: TNATTER on 07.10.2021 Doc.Vers. 06 Valid from: 20210209 Valid until: ... Status: Kundentfreigabe

Index 501/511

Index 502/512

Index 503/513

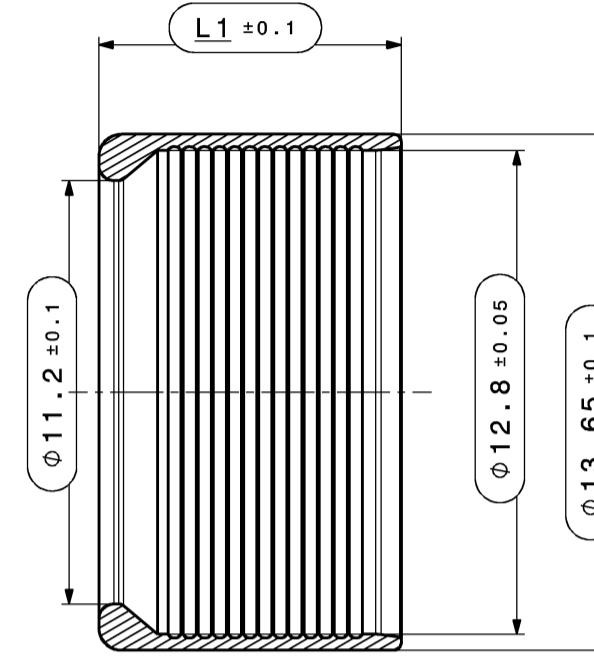
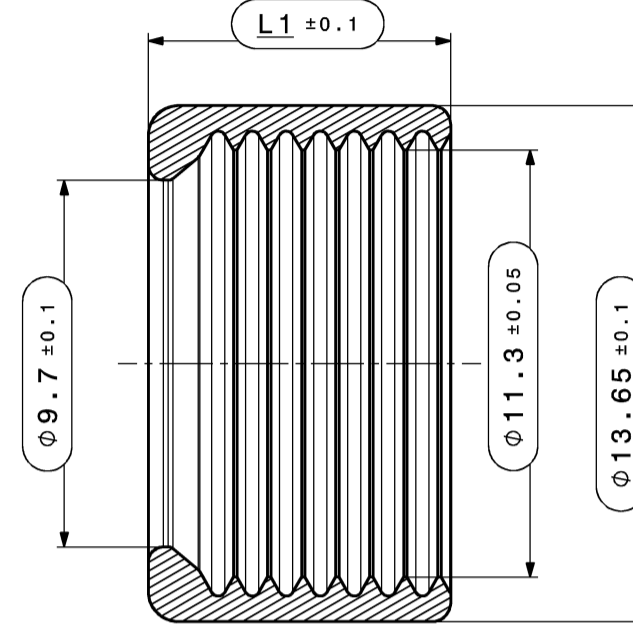
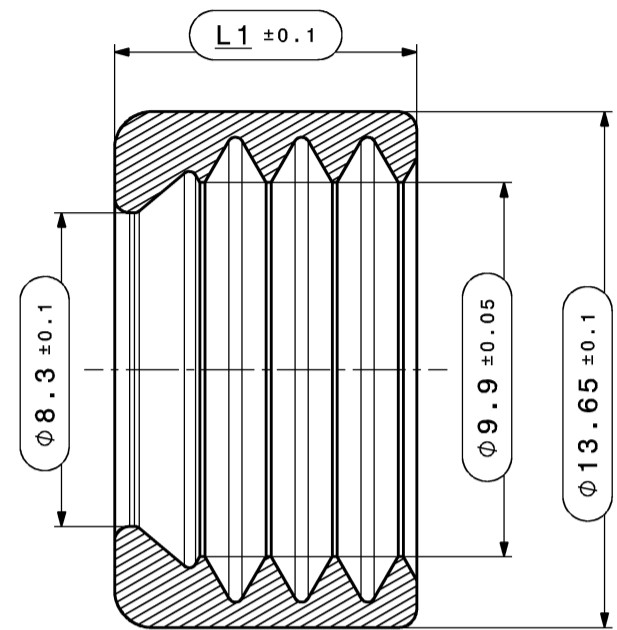
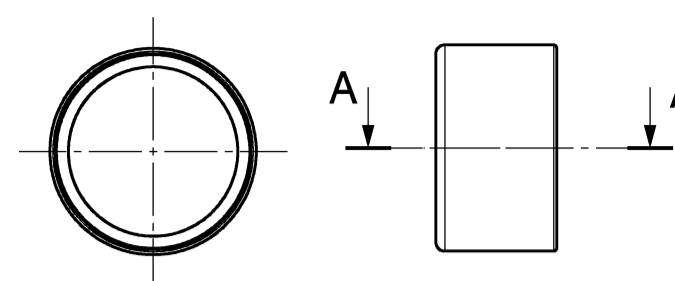
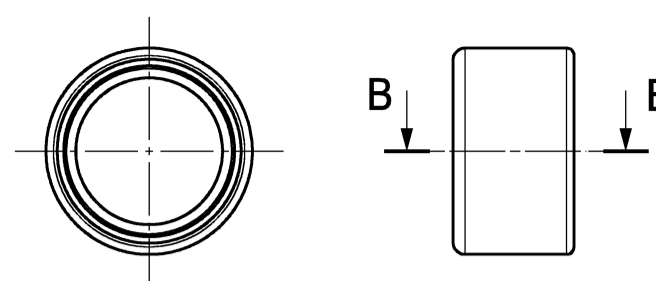
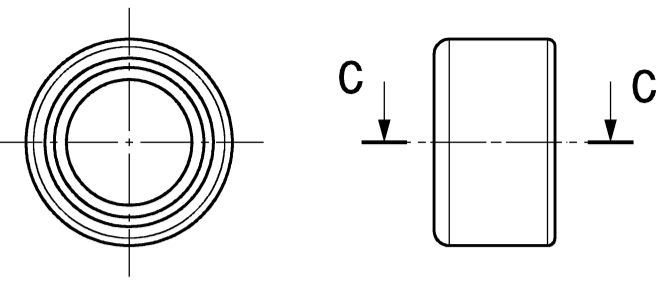

Schnitt C-C
Maßstab: 5:1
SECTION CUT C-C
SCALE: 5:1

Schnitt B-B
Maßstab: 5:1
SECTION CUT B-B
SCALE: 5:1

Schnitt A-A
Maßstab: 5:1
SECTION CUT A-A
SCALE: 5:1

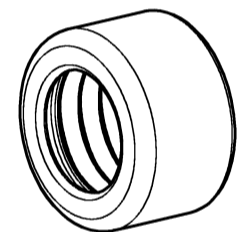

Isometrische Ansicht
ISOMETRIC VIEW

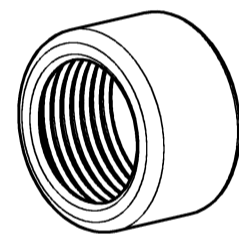

Isometrische Ansicht
ISOMETRIC VIEW

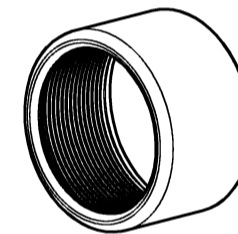

Isometrische Ansicht
ISOMETRIC VIEW

max. Formversatz ±0.1
MAX. SPLIT LINE ±0.1

Toleranzen fuer nicht tolerierte Masse:
1. Winkelmasse: (in °)
Fuer alle Winkelmasse gilt ±2°
2. Radien: (in mm)
3. Laengenmasse:
DIN 2768-mH
4. Allgemeintoleranz fuer Symmetrie: ±0.2

bis 1	1-3	3-10	10-20	20-30	30-50
±0.2	±0.3	±0.4	±0.5	±1	±2

TOLERANCES FOR UNTOLERATED DIMENSIONS:
1. ANGLE-DIMENSIONS (IN °)
TOLERANCE FOR ALL ANGLE-DIMENSIONS: ±2°
2. RADII: (IN mm)
3. DISTANCE-DIMENSIONS:
DIN 2768-mH
4. GENERAL TOLERANCE FOR SYMMETRY: ±0.2

TO 1	1-3	3-10	10-20	20-30	30-50
±0.2	±0.3	±0.4	±0.5	±1	±2

Bemerkungen:

COMMENTS:

1. massgebend ist der deutsche Text / GERMAN TEXT IS VALID
2. unbemaste Radien R0.3 +/- 0.1mm / UNDIMENSIONED RADII R0.3 +/-0.1mm
3. Funktionsbestimmende Maße, die mit gekennzeichnet sind, werden im EMPB dokumentiert. Nicht gekennzeichnete Maße werde ebenfalls ausgemessen, aber nicht im EMPB dokumentiert. Abweichungen sind zu korrigieren. DIMENSIONS WITH ARE DOCUMENTED IN THE INITIAL SAMPLE INSPECTION PREORT (ISIR). UNMARKED DIMENSIONS ARE ALSO MEASURED BUT NOT DOCUMENTED IN THE ISIR. VARIATIONS MUST BE CORRECTED.
4. Teil entspricht Altautorichtlinie nach DBL 8585
PART CORRESPONDS TO SCRAP CAR GUIDELINE DBL 8585

01

709-841-513	Kontakthuese lang CONTACT SLEEVE LONG	6mm ²	10	CuZn21Si3	2 g	A
709-841-512	Kontakthuese lang CONTACT SLEEVE LONG	4mm ²		CuZn21Si3	3,3 g	A
709-841-511	Kontakthuese lang CONTACT SLEEVE LONG	2,5mm ²		CuZn21Si3	4,5 g	A
709-841-503	Kontakthuese CONTACT SLEEVE	6mm ²	8	CuZn21Si3	2 g	A
709-841-502	Kontakthuese CONTACT SLEEVE	4mm ²		CuZn21Si3	3 g	A
709-841-501	Kontakthuese CONTACT SLEEVE	2,5mm ²		CuZn21Si3	4 g	A
Lft. Bestell Nr. ORDER NO.	Benennung TITLE	Leitungsquerschnitt WIRE CROSS SECTION	L1	Material MATERIAL	Gewicht WEIGHT	HA REV.

01 00	added index 511, 512, 513; Erstellung / Initial edition		25.05.2021 27.09.2017	rth JZI
Version	Numb. of	Description of alteration	Date	drwn
Test instructions				
Crude state	Material	Final state	Gross weight	g/pc
			Final weight	g/pc
Material-No.	Tolerances	DIN 2768-mH	Surface	cm ² /pc
Edges		DIN ISO 13715	dimensions	Scale
Geometric tolerances		DIN ISO 1101	in millimeters	2:1
Date	Name	Dimensions specially checked for acceptance		
Drawn	25.05.2021	R.Thöny	Title	
Checked	07.06.2021	T.Kleiner	Kontakthuese	
Released	07.06.2021	T.Kleiner	Type	
HIRSCHMANN AUTOMOTIVE			HIRSCHMANN PowerStar 40-2	
Oberer Paspelweg 6-8 A-6830 Rankweil-Brederis			Drawing - No. 709-841-...00	
Origin		Replacement		Sheet of 1
DNR 10000231170			Controlled status available in the system!	

This materials contain information protected by copyright. No part of this materials may be photocopied, otherwise reproduced or translated into another language without the prior written consent of Hirschmann. All rights reserved.

Plot from: TNAITER on 07.10.2021 Doc.Vers. 01 Valid from: 20210607 Valid until: ... Status: Kundenfreigabe

This materials contain information protected by copyright.
 No part of this materials may be photocopied, otherwise
 reproduced or translated into another language without
 the prior written consent of Hirschmann.
 All Rights reserved.

Diese Unterlage ist unser Eigentum. Jede Vervielfältigung, Verwertung,
 Mitteilung bzw. Weitergabe an Dritte ohne unsere vorherige Zustimmung
 ist untersagt. Zuwiderhandlungen verpflichten zu Schadenersatz. Alle
 Rechte fuer den Fall der Patenterteilung, Gebrauchs- bzw. Geschmacks-
 markenrechtliche Vorbehalten.

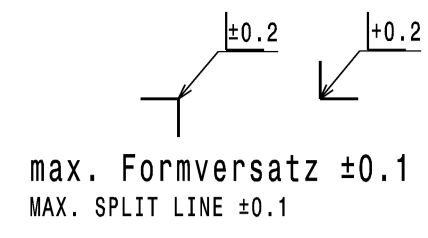

Toleranzen fuer nicht tolerierte Masse:

- Winkelmasse: (in °)
Fuer alle Winkelmasse gilt ±2°
- Radien: (in mm)

bis 1	1-3	3-10	10-20	20-30	30-50
±0.2	±0.3	±0.4	±0.5	±1	±2
- Laengemasse:
DIN 2768-mH
- Allgemeintoleranz fuer Symmetrie: $\begin{matrix} \text{---} \\ \text{---} \\ \text{---} \end{matrix} 0.2$

TOLERANCES FOR UNTOLERATED DIMENSIONS:

- ANGLE-DIMENSIONS (IN °)
TOLERANCE FOR ALL ANGLE-DIMENSIONS: ±2°
- RADII: (IN mm)

TO 1	1-3	3-10	10-20	20-30	30-50
±0.2	±0.3	±0.4	±0.5	±1	±2
- DISTANCE-DIMENSIONS:
DIN 2768-mH
- GENERAL TOLERANCE FOR SYMMETRY: $\begin{matrix} \text{---} \\ \text{---} \\ \text{---} \end{matrix} 0.2$

Bemerkungen:
COMMENTS:

- massgebend ist der deutsche Text / GERMAN TEXT IS VALID
- unbemasste Radien R0.2mm / UNDIMENSIONED RADII R0.2mm
- Funktionsbestimmende Maße, die mit --- gekennzeichnet sind, werden im EMPB dokumentiert. Nicht gekennzeichnete Maße werde ebenfalls ausgemessen, aber nicht im EMPB dokumentiert. Abweichungen sind zu korrigieren.
DIMENSIONS WITH --- ARE DOCUMENTED IN THE INITIAL SAMPLE INSPECTION PREORT (ISIR).
UNMARKED DIMENSIONS ARE ALSO MEASURED BUT NOT DOCUMENTED IN THE ISIR. VARIATIONS MUST BE CORRECTED.
- Teil entspricht Altautorichtlinie nach DBL 8585
PART CORRESPONDS TO SCRAP CAR GUIDELINE DBL 8585

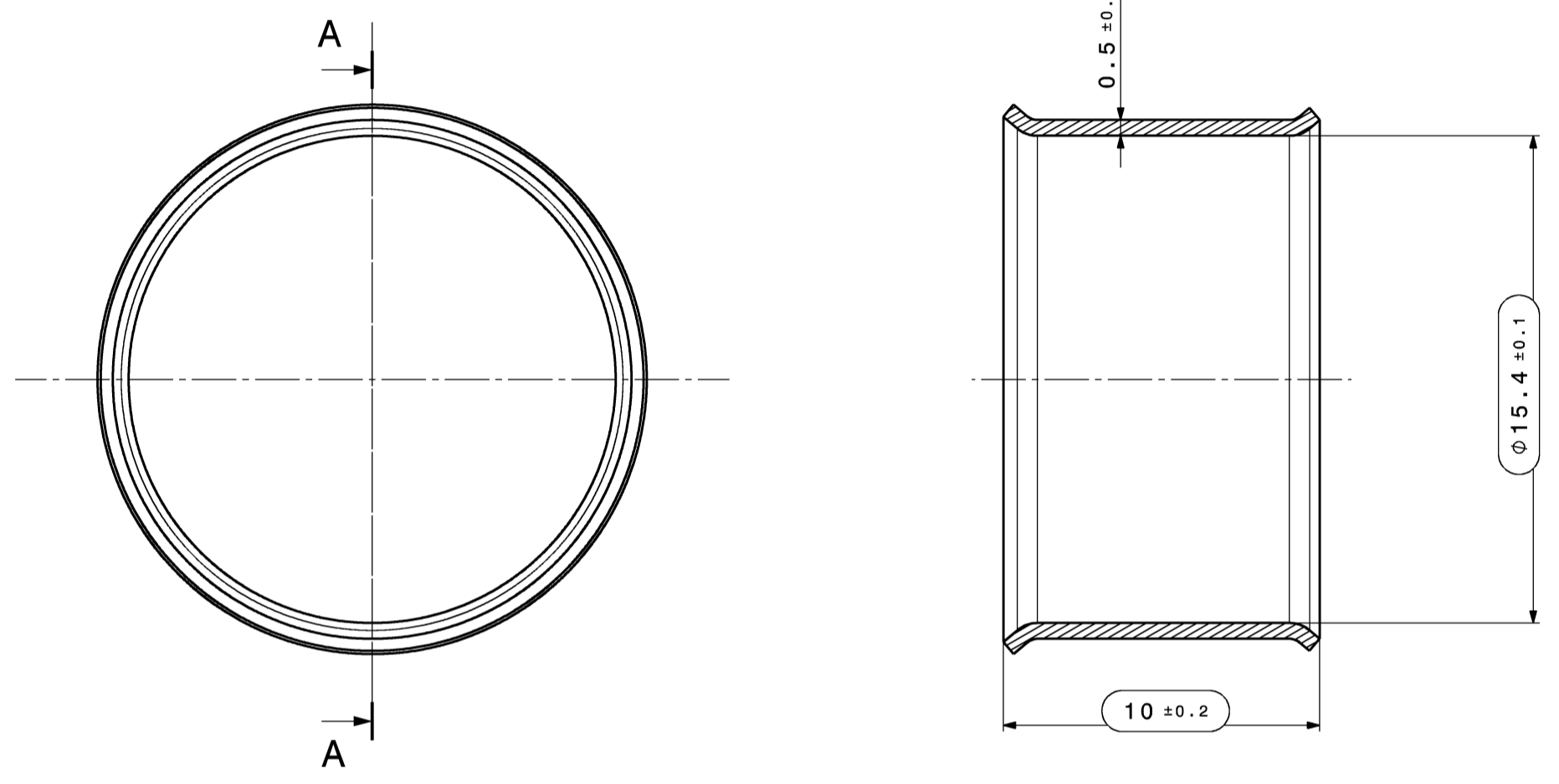

Schnittansicht A-A
CUT SECTION A-A



Isometrische Ansicht
Maßstab: 1:1
ISOMETRIC VIEW
SCALE: 1:1

710-099-501	CuZn28	-	2,8g	A
Lft. Bestell Nr. ORDER NO.	Material MATERIAL	Oberflaeche SURFACE	Gewicht WEIGHT	HA-REV.

00	Erstellung / Initial Edition		01.08.2018	RHO
Version	Anzahl pub. of	Aenderungsbeschreibung / description of alteration		Datum date
Pruefvorschriften / test instructions				
Rohzustand / crude state	Werkstoff / material	Fertigzustand / final state	Rohgewicht gross weight	g/Stk g/pc
			Fertig-gw. final weight	g/Stk g/pc
Material-Nr. / No.	Toleranzen / tolerances	Oberfl. surface	cm ² /Stk /pc	Abfall scrap
	Werkstueckkanten / edges	DIN ISO 13715	dimensions in millimeters	Massstab/scale 5:1
	Form- u. Lagetoleranzen / geometric tolerances	DIN ISO 1101	CAD System/ Version	
			CATIA V5	
Gezeichnet drawn	Datum / date	Name / name	Benennung title	
01.08.2018	Hoor		HPS Verteiler Schirmhülse	
geprueft checked	17.01.2019	Breuss	Typ type	
freigegeben released	17.01.2019	Schmid	CDI	
HIRSCHMANN AUTOMOTIVE		Zeichnungs - Nr. drawing - No.		Blatt / Sheet von / of
Oberer Paspelsweg 6-8 A-6830 Rankweil-Brederis		710-099-...00		1
Ursprung / origin		Ersatz fuer replacement		DNR 100000258205

Plot from: TNAITER on 12.10.2020 Doc.Vers. 00 Valid from: 20190117 Valid until: ... Status: Kundenfreigabe

This materials contain information protected by copyright. No part of this materials may be photocopied, otherwise reproduced or translated into another language without the prior written consent of Hirschmann. All rights reserved.

Diese Unterlage ist unser Eigentum. Jede Vervielfältigung, Verwertung, Mitteilung bzw. Weitergabe an Dritte ohne unsere vorherige Zustimmung ist untersagt. Zuwiderhandlungen verpflichten zu Schadenersatz. Alle Rechte fuer den Fall der Patenterteilung, Gebrauchs- bzw. Geschmacks-mustereintragung vorbehalten.

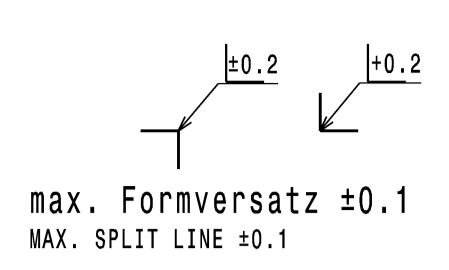

Toleranzen fuer nicht tolerierte Masse:

- Winkelmasse: (in °)
Fuer alle Winkelmasse gilt ±2°
- Radien: (in mm)

bis 1	1-3	3-10	10-20	20-30	30-50
±0.2	±0.3	±0.4	±0.5	±1	±2

- Laengenmasse:
DIN 2768-mH
- Allgemeintoleranz fuer Symmetrie: ±0.2

TOLERANCES FOR UNTOLERATED DIMENSIONS:

- ANGLE-DIMENSIONS (IN °)
TOLERANCE FOR ALL ANGLE-DIMENSIONS: ±2°
- RADII: (IN mm)

TO 1	1-3	3-10	10-20	20-30	30-50
±0.2	±0.3	±0.4	±0.5	±1	±2

- DISTANCE-DIMENSIONS:
DIN 2768-mH
- GENERAL TOLERANCE FOR SYMMETRY: ±0.2

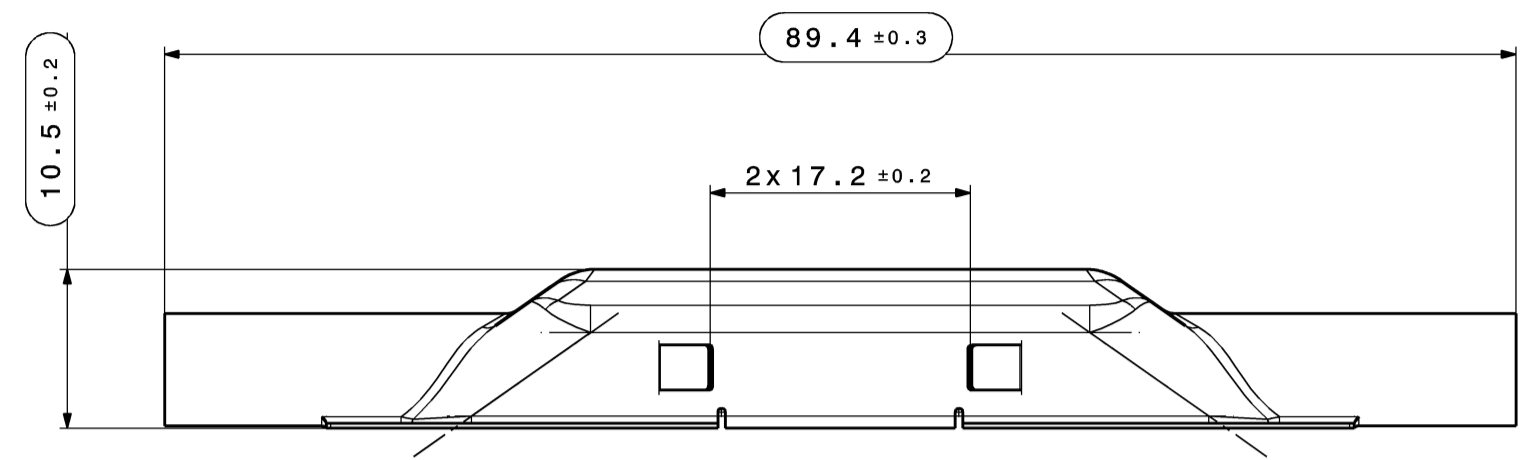

Bemerkungen:

COMMENTS:

- massgebend ist der deutsche Text / GERMAN TEXT IS VALID
- unbemaste Radien R0.2mm / UNDIMENSIONED RADII R0.2mm
- Funktionsbestimmende Maße, die mit gekennzeichnet sind, werden im EMPB dokumentiert. Nicht gekennzeichnete Maße werde ebenfalls ausgemessen, aber nicht im EMPB dokumentiert. Abweichungen sind zu korrigieren. DIMENSIONS WITH ARE DOCUMENTED IN THE INITIAL SAMPLE INSPECTION PREORT (ISIR). UNMARKED DIMENSIONS ARE ALSO MEASURED BUT NOT DOCUMENTED IN THE ISIR. VARIATIONS MUST BE CORRECTED.
- Teil entspricht Altautorichtlinie nach DBL 8585
PART CORRESPONDS TO SCRAP CAR GUIDELINE DBL 8585

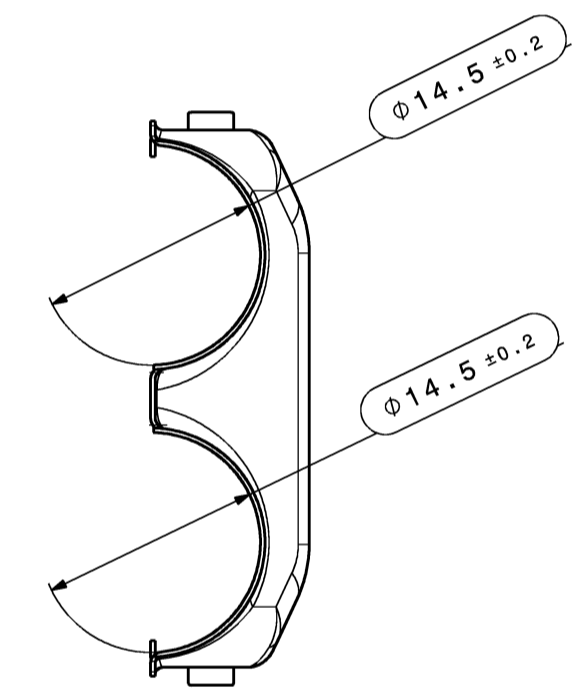
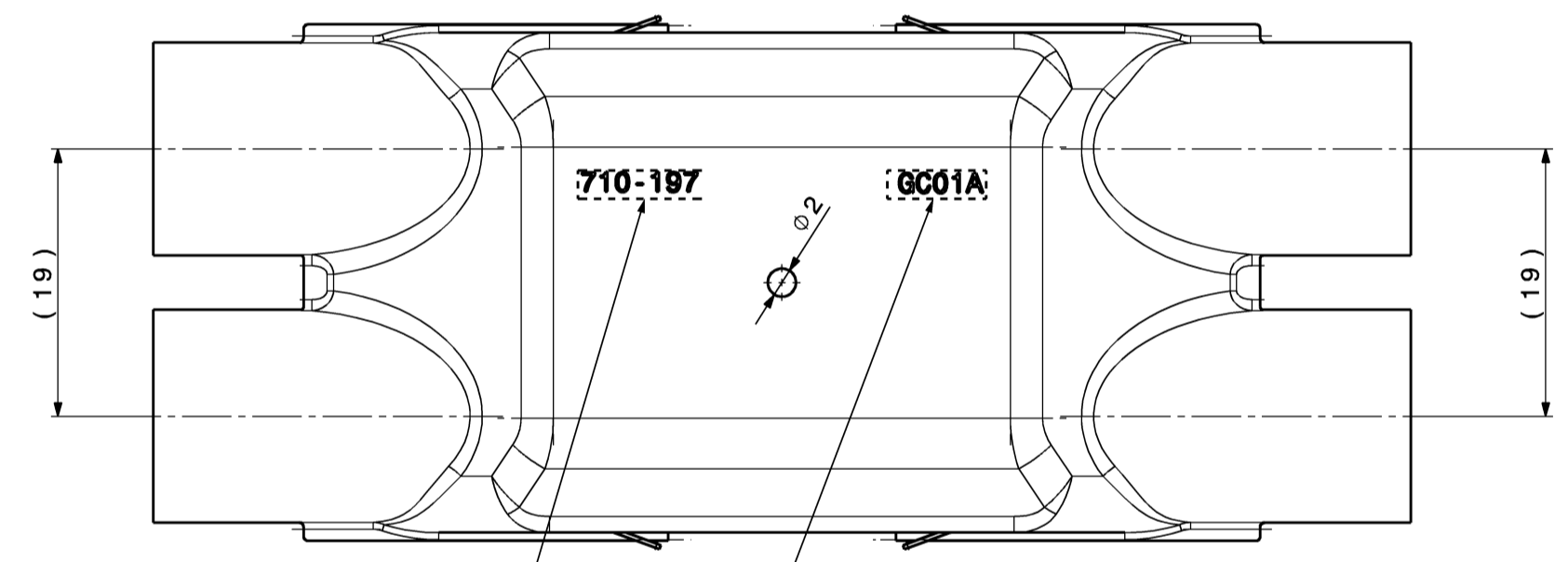
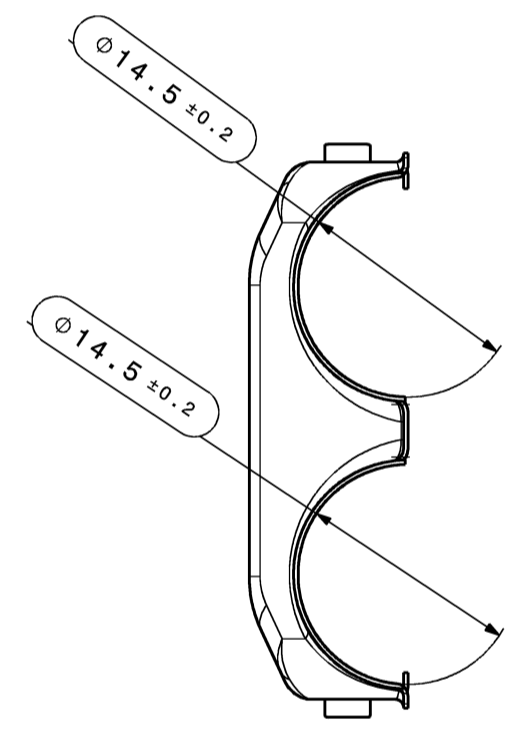

Bauteilnummer
vertieft
PART NUMBER
RECESSED

 Kennzeichnungscode
vertieft siehe Matrix
IDENTIFICATION CODE
RECESSED SEE MATRIX

Kennzeichnungsmatrix IDENTIFICATION MATRIX		Anzahl Merkmale AMOUNT OF FEATURES
Monat: MONTH:	A(Jan), B(Feb), C(Maerz), ... L(Dez)	1
Jahr: YEAR:	A(2018), B(2019), C(2020), ... Z(2043)	1
Produkt Index: PRODUCT INDEX:	01, 02, 03, ... 99	2
Teile Rev. Stand: PART REV. INDEX:	A, B, C, ... Z	1
Beispiel: G C 01 A = G(Monat_7), C(Jahr_2020), 01(Index_001), A(Rev. A) SAMPLE: G C 01 A = G(MONTH_7), C(YEAR_2020), 01(Index_001), A(REV. A)		

710-197-501	CuZn28	3-5µm verzinkt 3,5µm TINNED	11,40g	A
Lft. Bestell Nr. ORDER NO.	MATERIAL	Oberflaeche SURFACE	Gewicht WEIGHT	HA-REV.

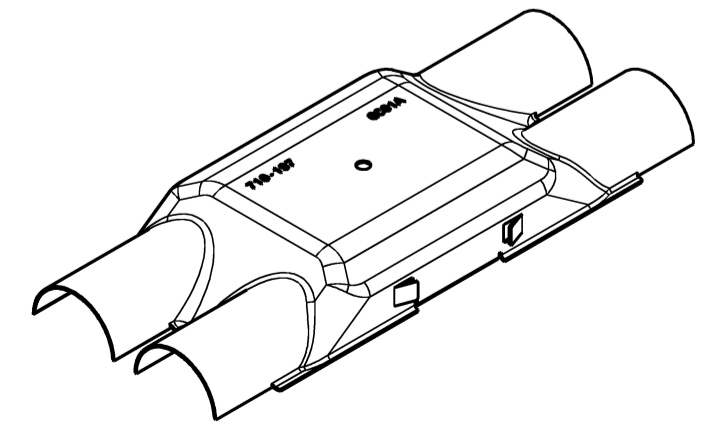

Isometrische Ansicht
 Maßstab: 1:1
 ISOMETRIC VIEW
 SCALE: 1:1

00	Erstellung / Initial Edition		01.08.2018	RHO
Version	Anzahl pub. of	Aenderungsbeschreibung / description of alteration		Datum date
Pruefvorschriften / test instructions				
Rohzustand / crude state	Werkstoff / material	Fertigzustand / final state	Rohgewicht gross weight	g/Stk g/pc
			Fertig-gw. final weight	g/Stk g/pc
Material-Nr. / No.	Toleranzen / tolerances		oberfl. surface	cm² /Stk /pc
	Werkstueckkanten / edges		dimensions in millimeters	Abfall scrap
	DIN ISO 13715		2:1	Abfall scrap
	Form- u. Lagetoleranzen / geometric tolerances		DIN ISO 1101	CAD System/ Version
Gezeichnet drawn	Datum / date	Name / name	<input type="checkbox"/> Masse werden bei Abnahme besonders geprueft / dimensions specially checked for acceptation	
geprueft checked	17.01.2019	Breuss	Benennung title	
freigegeben released	17.01.2019	Schmid	HPS Verteiler Schirmblech H	
HIRSCHMANN AUTOMOTIVE		Zeichnungs - Nr. drawing - No.		Blatt / Sheet von / of
Oberer Paspelweg 6-8 A-6830 Rankweil-Brederis		Ersatz fuer replacement		DNR 10000258209
Controlled status available in the system!				

Plot from: TNAITER on 12.10.2020 Doc.Vers. 00 Valid from: 20190117 Valid until: ... Status: Kundenfreigabe

Index 501

[1] Kabelgehäuse
CABLEHOUSING

[3] Dichtung
SEAL

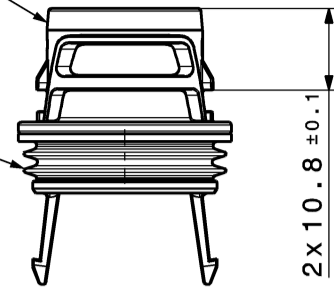

-Formteilnummer
vertieft
MOLD CAVITY NO.
RECESSED

-Materialkennzeichnung
vertieft
MATERIAL DESCRIPTION
RECESSED

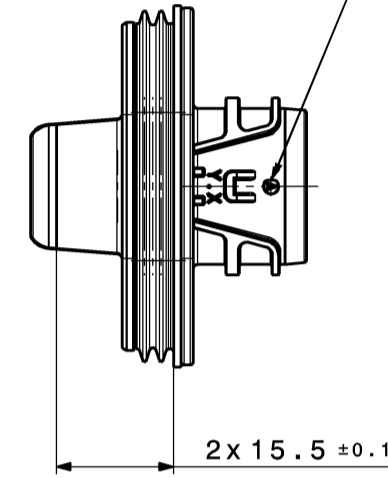
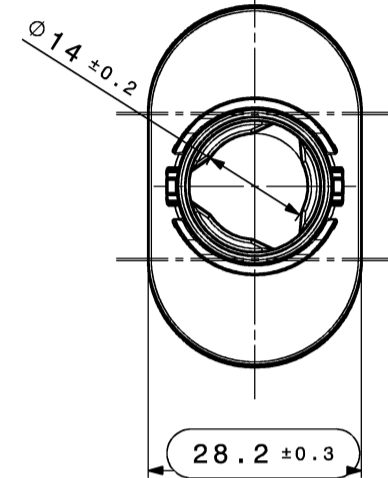
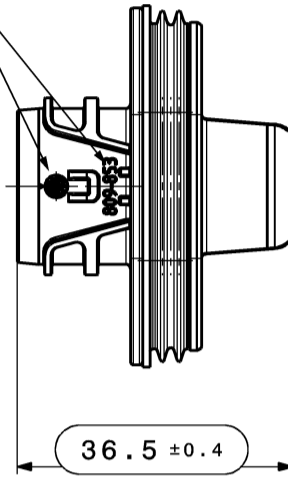

-Datum D3
vertieft
DATE D3
RECESSED

-HA Revision
HA REVISION

max. Formversatz ±0.1
MAX. SPLIT LINE ±0.1

Toleranzen fuer nicht tolerierte Masse:
1. Winkelmasse: (in °)
Fuer alle Winkelmasse gilt ±2°
2. Radien: (in mm)

bis 1	1-3	3-10	10-20	20-30	30-50
±0.2	±0.3	±0.4	±0.5	±1	±2

3. Laengenmasse:
DIN 2768-mH
4. Allgemeintoleranz fuer Symmetrie: ±0.2

TOLERANCES FOR UNTOLERATED DIMENSIONS:
1. ANGLE-DIMENSIONS (IN °)
TOLERANCE FOR ALL ANGLE-DIMENSIONS: ±2°
2. RADII: (IN mm)

TO 1	1-3	3-10	10-20	20-30	30-50
±0.2	±0.3	±0.4	±0.5	±1	±2

3. DISTANCE-DIMENSIONS:
DIN 2768-mH
4. GENERAL TOLERANCE FOR SYMMETRY: ±0.2

Bemerkungen:

COMMENTS:

1. massgebend ist der deutsche Text / GERMAN TEXT IS VALID
2. unbemaste Radien R0.3 +/- 0.1mm / UNDIMENSIONED RADII R0.3 +/-0.1mm
3. Funktionsbestimmende Maße, die mit gekennzeichnet sind, werden im EMPB dokumentiert. Nicht gekennzeichnete Maße werde ebenfalls ausgemessen, aber nicht im EMPB dokumentiert. Abweichungen sind zu korrigieren. DIMENSIONS WITH ARE DOCUMENTED IN THE INITIAL SAMPLE INSPECTION PREORT (ISIR). UNMARKED DIMENSIONS ARE ALSO MEASURED BUT NOT DOCUMENTED IN THE ISIR. VARIATIONS MUST BE CORRECTED.
4. Teil entspricht Altautorichtlinie nach DBL 8585
PART CORRESPONDS TO SCRAP CAR GUIDELINE DBL 8585
5. Teilekennzeichnung angelehnt an MBN 10435
PART IDENTIFICATION SIMILAR MBN 10435
6. Max. 30% Regranulat zulaessig / MAX. 30% RECLAIM ACCEPTABLE

Tabelle der Einzelteile TB TABLE OF INDIVIDUAL PARTS TB			
Pos.	Benennung DESCRIPTION	Farbe COLOUR	Material MATERIAL
1	Kabelgehäuse einfach CABLEHOUSING ONE	orange, aehnlich RAL2003	PA6 GF30
2	Kabelgehäuse zweifach CABLEHOUSING TWO	ORANGE, SIMILAR RAL 2003	
3	Dichtung SEAL	gelb, aehnlich RAL1016	LSR 50 Shore A

Index 502

-HA Revision
HA REVISION

-Formteilnummer
vertieft
MOLD CAVITY NO.
RECESSED

-Materialkennzeichnung
vertieft
MATERIAL DESCRIPTION
RECESSED

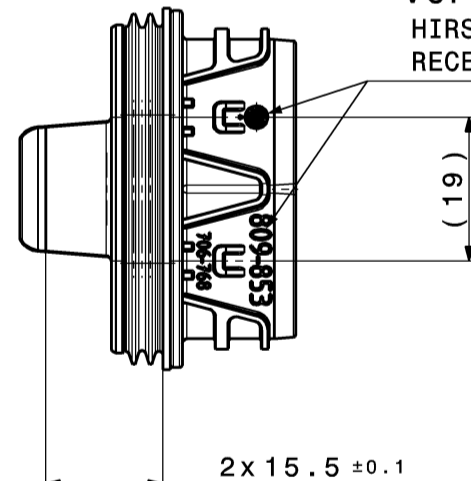
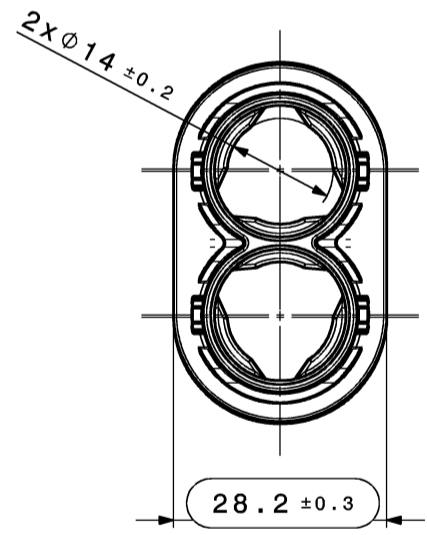
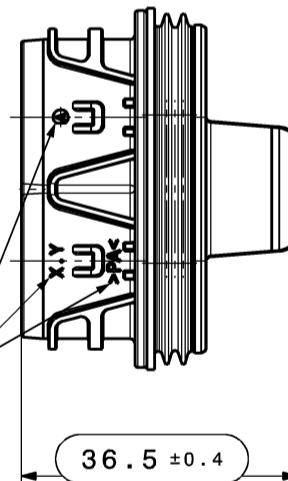

-Datum D3
vertieft
DATE D3
RECESSED

-Hirschmann Nr.
vertieft
HIRSCHMANN NO.
RECESSED

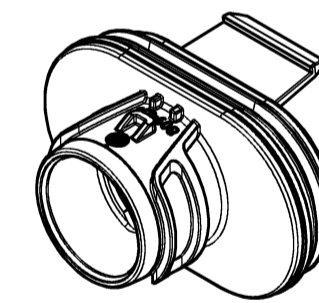

Isometrische Ansicht
ISOMETRIC VIEW
Index 501

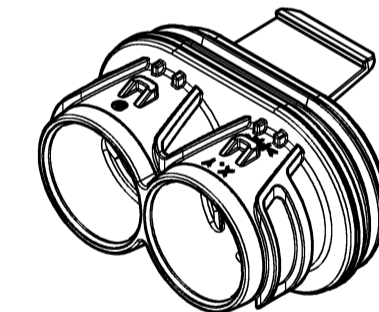

Isometrische Ansicht
ISOMETRIC VIEW
Index 502

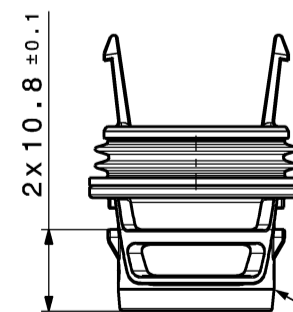

[3] Dichtung
SEAL

[2] Kabelgehäuse
CABLEHOUSING

809-853-502	ZB Kabelgehäuse zweifach TB CABLEHOUSING TWO	10,5g	A
809-853-501	ZB Kabelgehäuse einfach TB CABLEHOUSING ONE	9,2g	A
Lft. Bestell Nr. ORDER NO.	Benennung TITLE	Gewicht WEIGHT	HA REV.

01 00	changed Material for Pos. 1 und Pos. 2 Ersterstellung / Initial edition	14.07.2021 31.07.2018	WRI RHO
Version	Numb. of	Description of alteration	Date
Test instructions			
Crude state	Material	Final state	Gross weight g/pc
			Final weight g/pc
Material-No.	Tolerances	EN ISO 8015	Surface cm²/pc
Edges		DIN ISO 13715	Scrap %
Geometric tolerances		DIN ISO 1101	dimensions in millimeters
Date		Name	Scale 1:1
Drawn	14.07.2021	W.Ribitsch	Title ZB Kabelgehäuse
Checked	14.07.2021	L.Breuss	
Released	14.07.2021	L.Breuss	
HIRSCHMANN AUTOMOTIVE			BS
Oberer Paspelsweg 6-8 A-6830 Rankweil-Brederis			Drawing - No. 809-853-...00
Origin		Replacement	Sheet of 1
DNR 10000258015		Controlled status available in the system!	

This materials contain information protected by copyright. No part of this materials may be photocopied, otherwise reproduced or translated into another language without the prior written consent of Hirschmann. All rights reserved.

Plot from: TNAITER on 20.09.2021 Doc.Vers. 01 Valid from: 20210714 Valid until: ... Status: Kundenfreigabe