

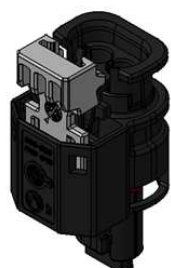

HIRSCHMANN
AUTOMOTIVE

Processing Specification

1.2 HMK Female Housings



2-Way

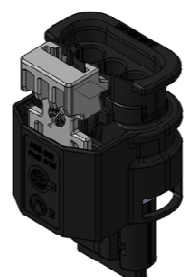

3-Way

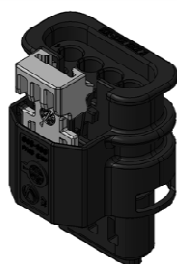

4-Way

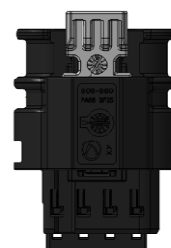

5-Way

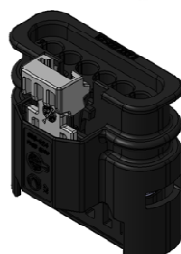
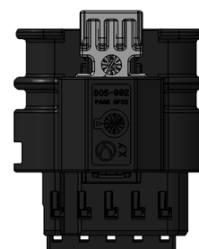

6-Way

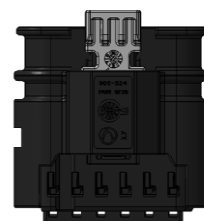

EVS-100059-00
Edition 02

1. Index

1. Index.....	2
2. General Information	3
2.1. Introduction	3
2.2. Applying relevant Information/Documentation	3
3. Delivery Condition / Product Components	4
3.1. Delivery Condition	4
4. Usable contacts	5
4.1. Usable contacts with SEAL	5
5. Assembling and disassembling of contacts	6
5.1. Assembling of contacts	6
5.1.1. Primary locking mechanism / Secondary locking mechanism	6
5.1.2. Contact position and electrical testing.....	6
5.2. Demounting of the contacts.....	7
6. Connection and disconnection of the connectors	9
6.1. Connect the HMK housing	9
6.2. Disconnect the HMK housing (interlocking connection) with CPA	12
7. Protection caps / angled outlet caps	13
8. Index change table	15

2. General Information

2.1. Introduction

This processing specification is valid for all 1.2 HMK housings and describes the delivery conditions, the product components as well as the assembling and disassembling of the housings and contacts.

Based on the processing specification for 1.2 HMK contacts of the company Hirschmann the contact assembling and disassembling is described.

The processor of the products mentioned in this specification is responsible for the processing quality and the specified execution.

In case of inappropriate, deviating processing and subsequent quality problems the right of recourse will be rejected.

2.2. Applying relevant Information/Documentation

- | | | |
|----|--|---|
| a) | Product Specification
EPS-100059-00 | HMK 1.2mm housings |
| b) | Product Specification
EPS-100062-00 | HMK 1.2mm contacts |
| c) | Processing Specification
EVS-100062-00 | HMK 1.2mm contacts |
| d) | „Deutsche Norm“
DIN EN 60352-2 | solder free electrical connection
part 2: crimp connection |
| e) | Test guideline GS95006-7-1
LV-214 (03-2010) | Motor vehicle connectors |
| f) | Working instruction
872-975-...00 | AV Plug Socket 2-Way – 6-Way 1.2 |

3. Delivery Condition / Product Components

3.1. Delivery Condition

The waterproof running housing consists of female housing, protective shroud, seals and CPA.

The housing will be delivered in the assembled condition, with the protective shroud and the CPA in pre-lock position.

To connect a protective cap a defined contour is provided.
(identical to the sealstar housings).

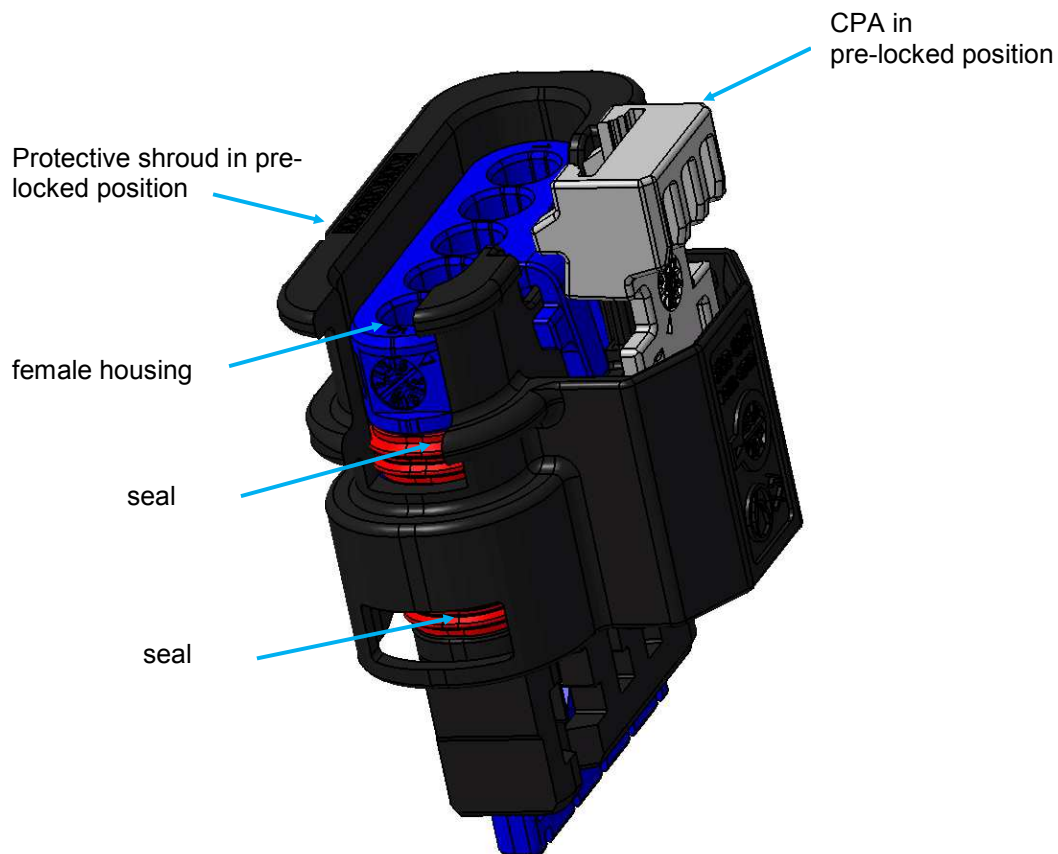

4. Usable contacts

4.1. Usable contacts with SEAL

Contact system:

„Hochleistungsmotorkontakt“ (high-performance contact) HMK 1.2 see
Hirschmann-Drawing 709-125-...00

Corresponding processing tools see processing specification:
HMK 1.2mm contact: EVS-100062-00

To guarantee the required tightness of the system it is absolutely necessary to use all contacts with corresponding seal and in case of reduced contact assembly to close the open chambers with a single wire dummy plug. Exceptions are versions with closed chambers. In these options no seals or dummy plugs are necessary.

5. Assembling and disassembling of contacts

5.1. Assembling of contacts

5.1.1. Primary locking mechanism / Secondary locking mechanism

The contact housing is delivered ready for assembly. During the assembly the primary locking mechanism and the secondary locking mechanism engages in the housing.

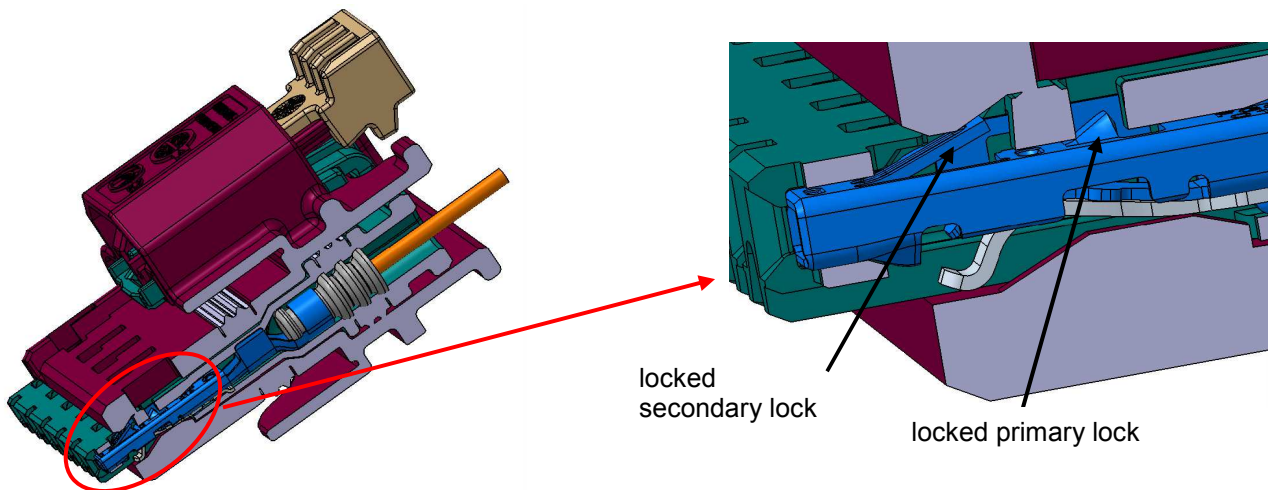

5.1.2. Contact position and electrical testing

Following the assembly, a push-pull-test must be performed. At this test you have to pull with ~10N in cable outgoing direction to check the contact locking. The electrical test must be made with the test pin in the designated test hole.

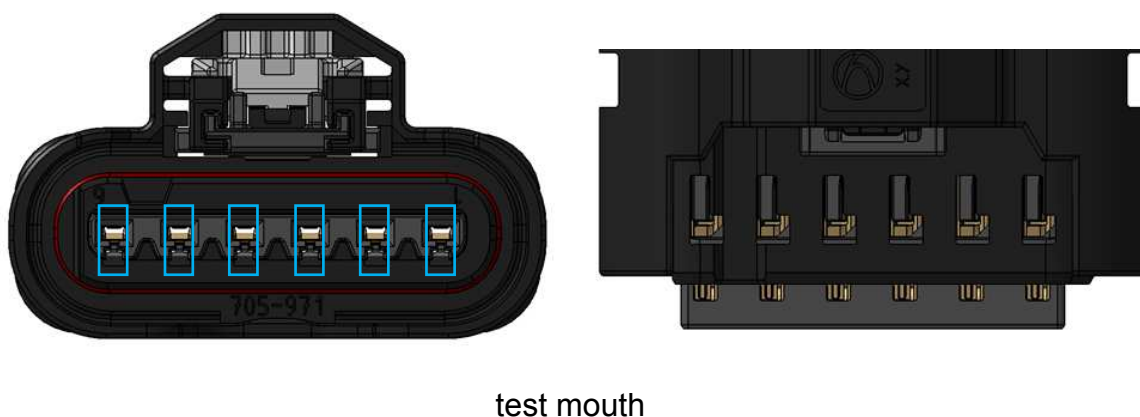

5.2. Demounting of the contacts

The contacts can be removed for repair. For that you have to perform the following steps:

1. The bow of the contact housing must be cut to solve the protective shroud from the contact housing. The cable insulation must not be damaged.

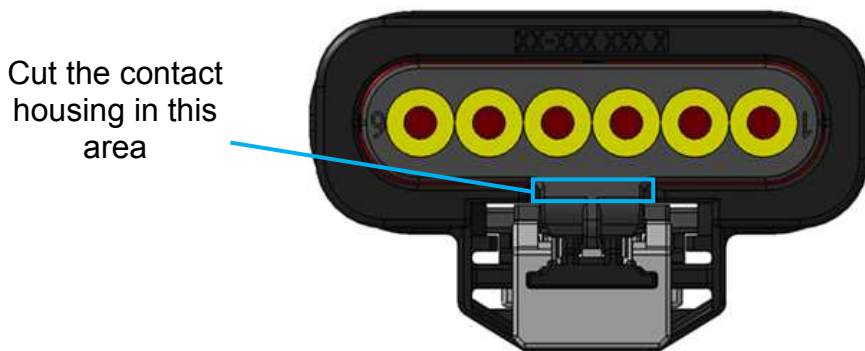

2. By pressing the contact housing in cable outgoing direction the protective shroud can be resolved.

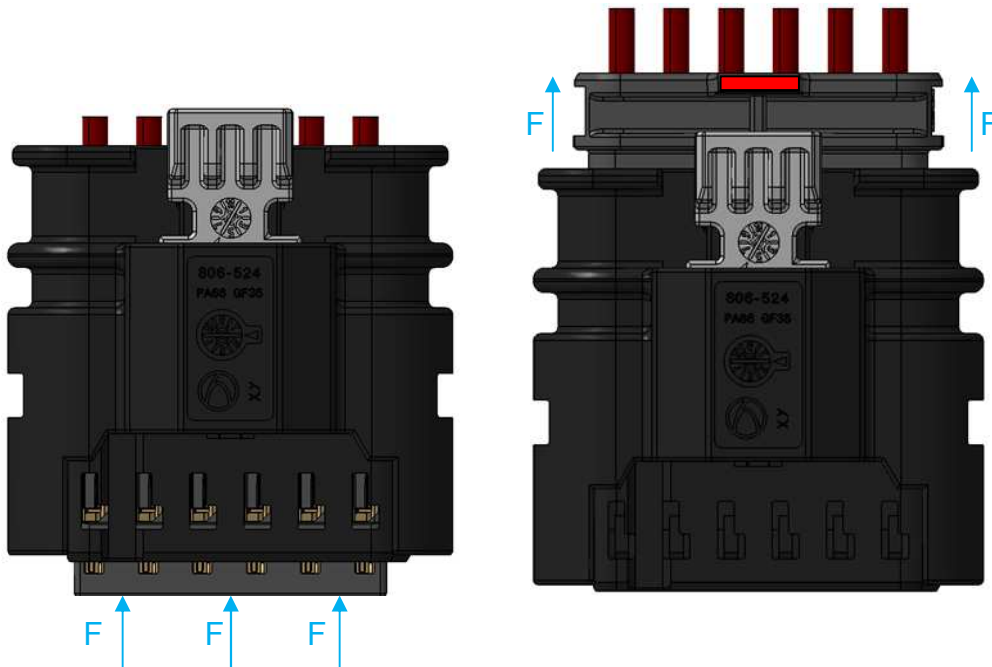

3. The primary lock latch at the contact housing must be removed.
The contact must not be damaged!

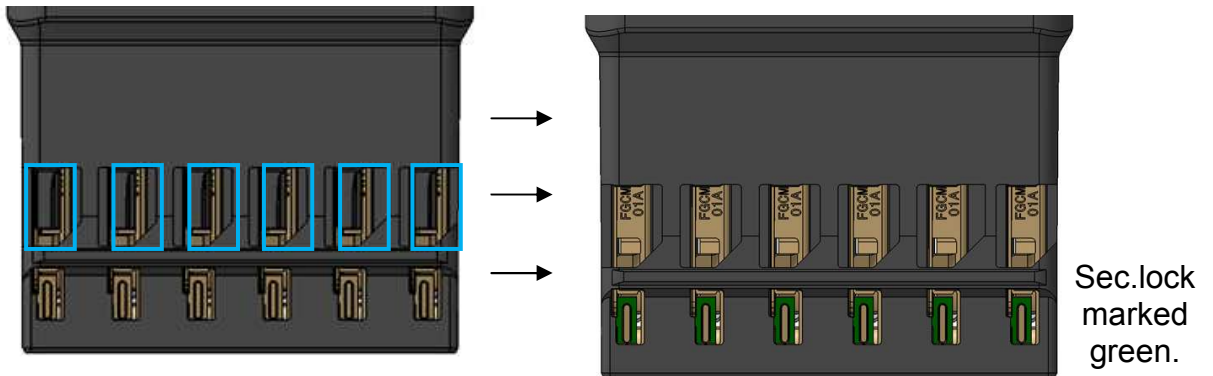

4. The secondary lock must be operated with the appropriate removal tool.
Subsequently the operated contact can be removed by pulling in cable outgoing direction.

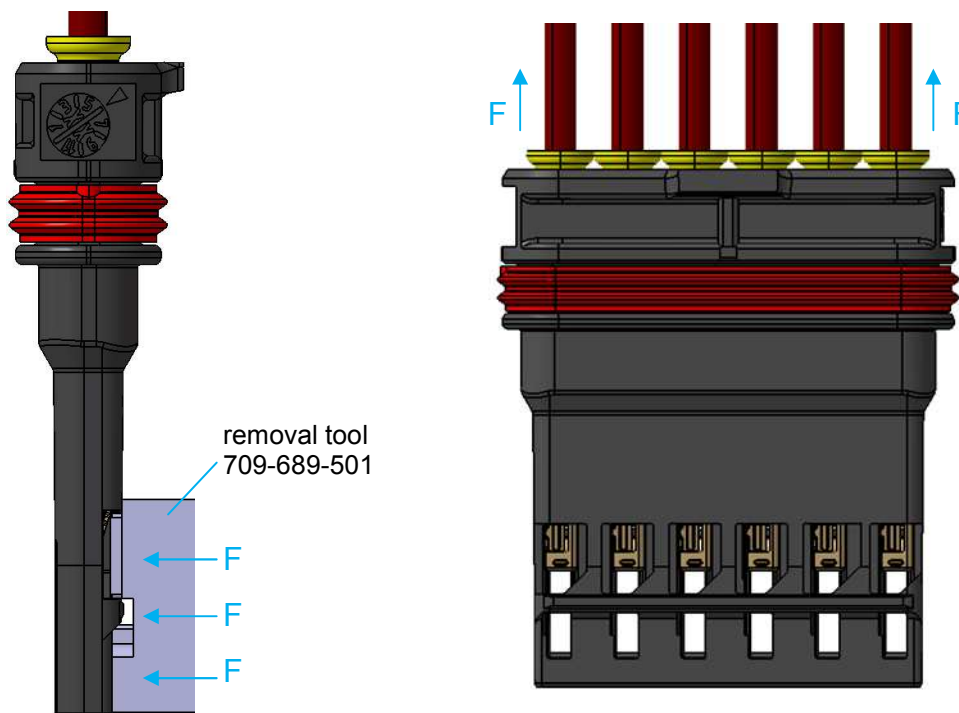

5. If the contacts are free of damage separate from the contact housing, the HMK-housing is to be replaced with a new part. Protective shroud, contact housing and CPA may not be used! It is recommended to also replace the contacts after disassembly.

Removal tool from company Hirschmann: Hirschmann order no. 709-689-501

6. Connection and disconnection of the connectors

6.1. Connect the HMK housing

Following the mounting of the contacts, the connector can be completed by the mounting of the housing in a suitable socket. For this the housing has to be insert vertically in a suitable socket until the locking hook is locked. Only after a correct locking of the housing, the CPA can be pushed from the pre-locked position in the final locked position. In the final locked position the protective shroud is flush with the contact housing. The CPA is in its final locked position flush with the housing.

It's forbidden to push the housing with the CPA.

1. push the housing on the socket.

2. Now, the housing is in the final locked position. The CPA is deflected by the contact housing and can now be pushed into the final locked position.

3. The CPA is in its final locked position.

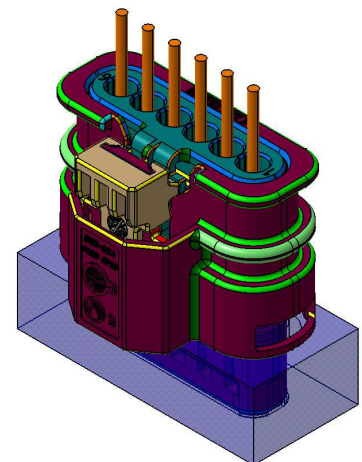
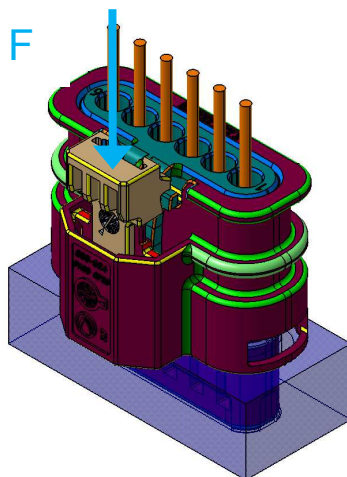
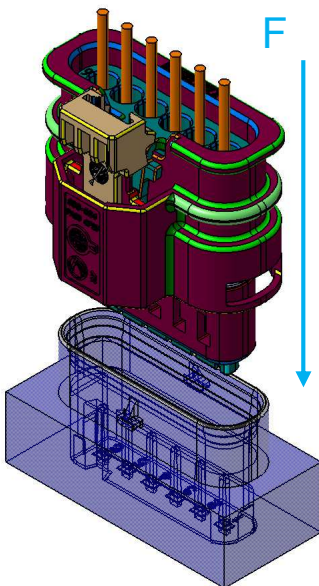

In order to assure a correct mounting of the housing, it's forbidden to move or press the CPA during the mounting process (like shown at the side)! Generally it's only allowed to press the CPA during the demounting of the housing.

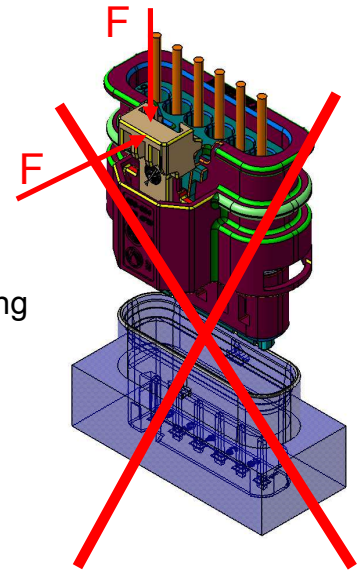

It's important to press the Housing during the mounting on the protective shroud. Mounting the Housing with the CPA is strictly permitted.

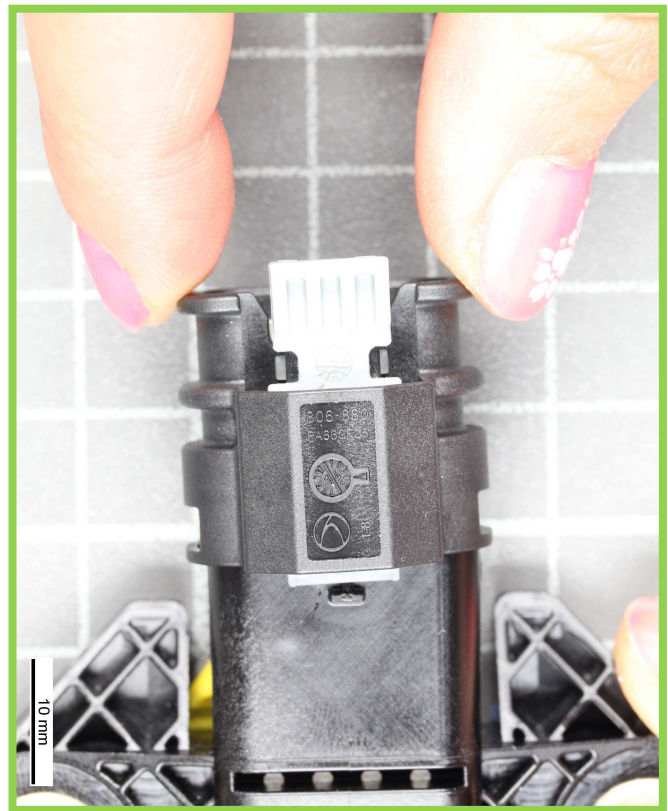

housing in end-lock position

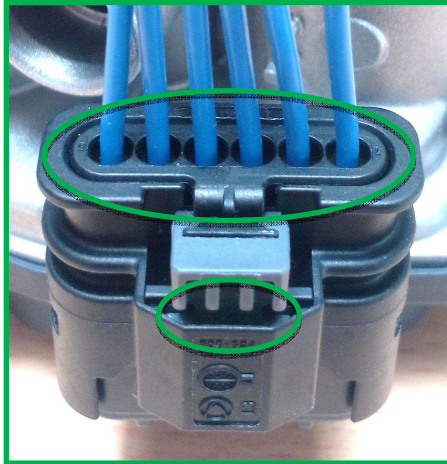

CPA in pre-lock position

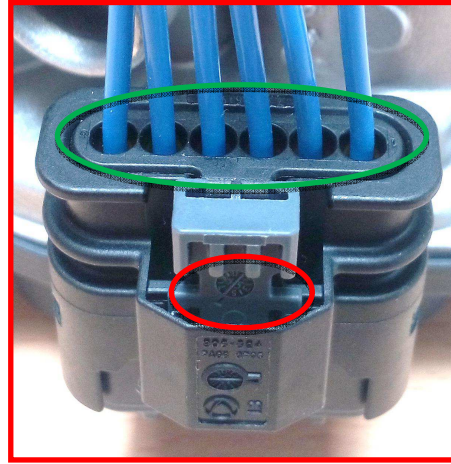

protective shroud +
 CPA in pre-lock position

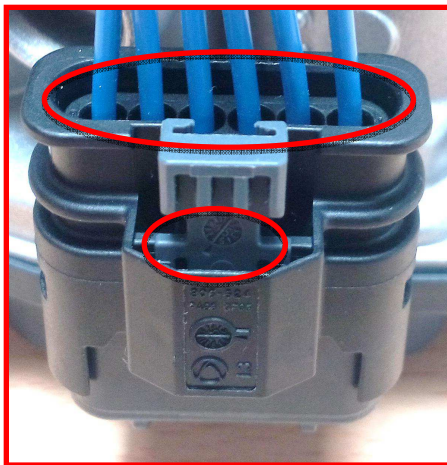

female housing +
 protective shroud +
 CPA in pre-lock position



It is important to ensure that the HMK is only used with a socket with a closed bottom. (Only partial exemptions are allowed in the area of the locating surface of the HMK housing.)

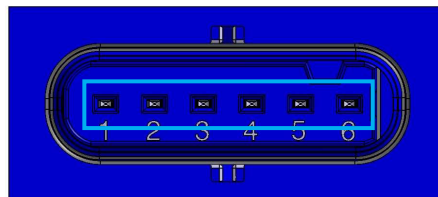

6.2. Disconnect the HMK housing (interlocking connection) with CPA

The housing is held positively in the socket. To release the connector, the CPA must first be pushed back into the cable outlet direction in the pre-locking position, only then the locking hock can be operated by pushing in the illustrated direction. By pulling in the direction of the cable outlet, the connector can be disassembled.

Remove the housing in no case by pulling on the cable set!

After disassembly the housing take care that the contact housing is back in pre-locked position.

1. push CPA from locked position in pre-locked position.

2. push the locking hock in illustrated direction.

3. Press and hold the locking hock by pulling the housing in cable outlet direction.

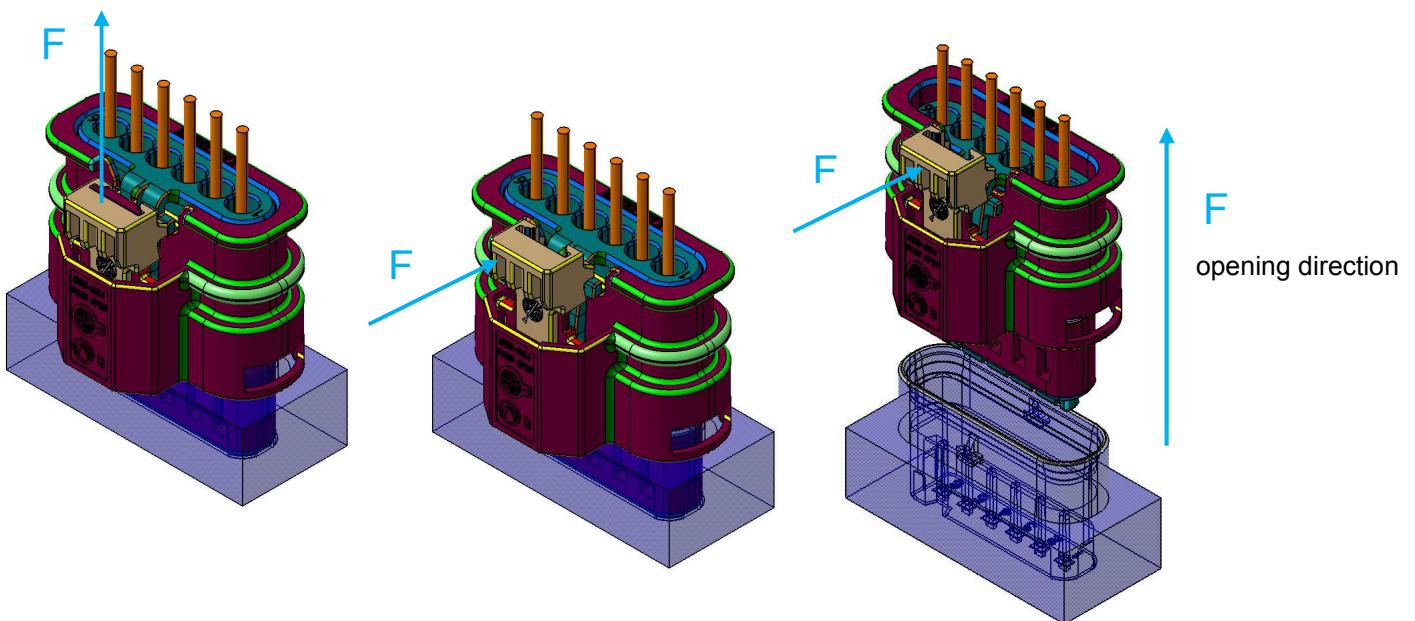

After disassembly the housing take care that the contact housing is back in pre-locked position. If it is not in pre-locked position, by pressing again on the CPA the contact housing can be pushed into pre-locked position by pushing contrary to the cable outlet direction.

7. Protection caps / angled outlet caps

If protection caps or angled outlet caps must be used, you have to take care that the wires have enough space inside the cap. The wiring need during the assembly and disassembly process a range of min. 3mm, so that the protective shroud can be pushed into pre-locked position again.

If the wires are clamped after mounting the cap, the protective shroud cannot be pushed back to the position during disassembly. That means that the HMK housing is still in the final locked position and an new assembly is not possible.

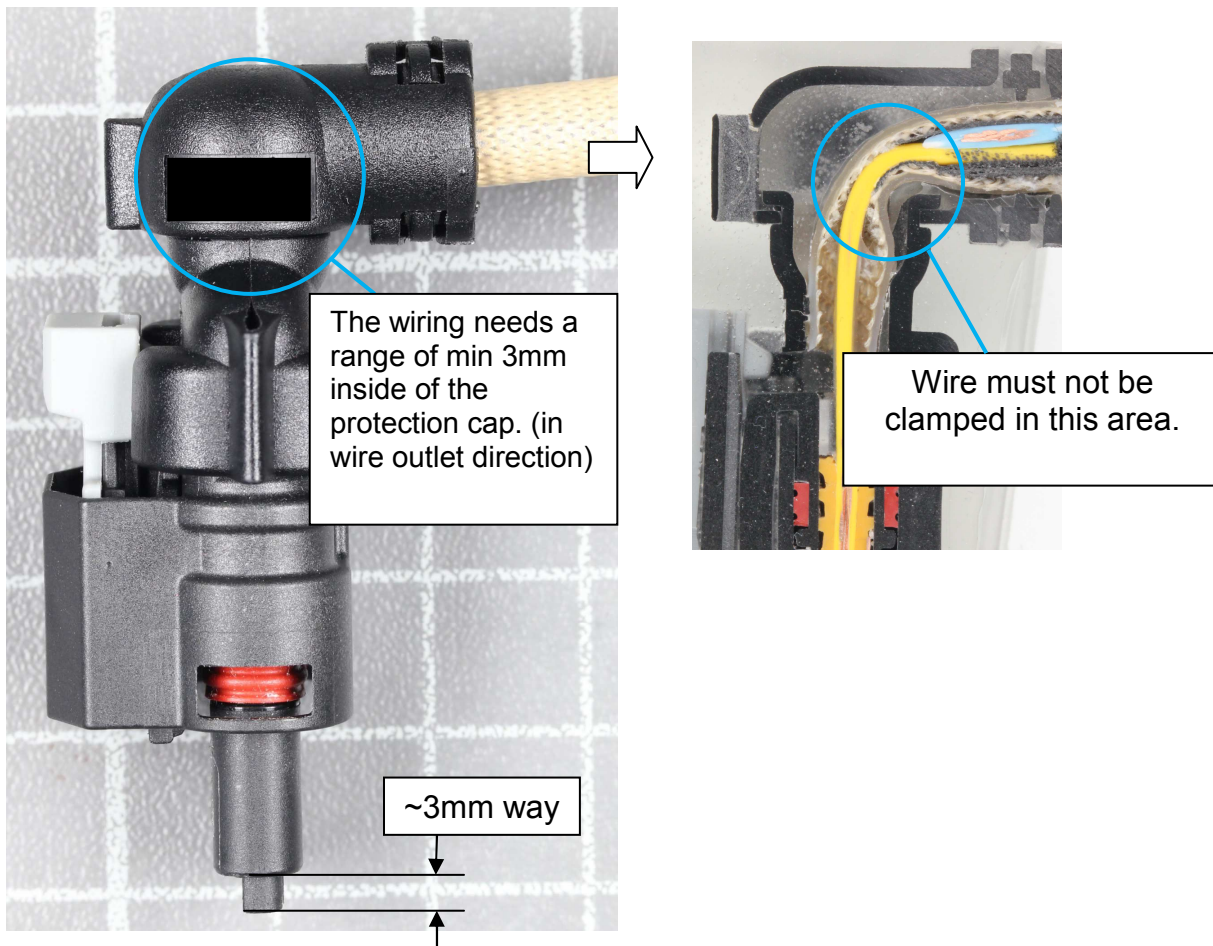

Further you have to take care, that the traversing distance (approximately 3mm) of the contact housing is not blocked while the plug operation. Especially by the use of corrugated pipes you have to take care. If this is not ensured, the connectors can not be brought in the final locked position.

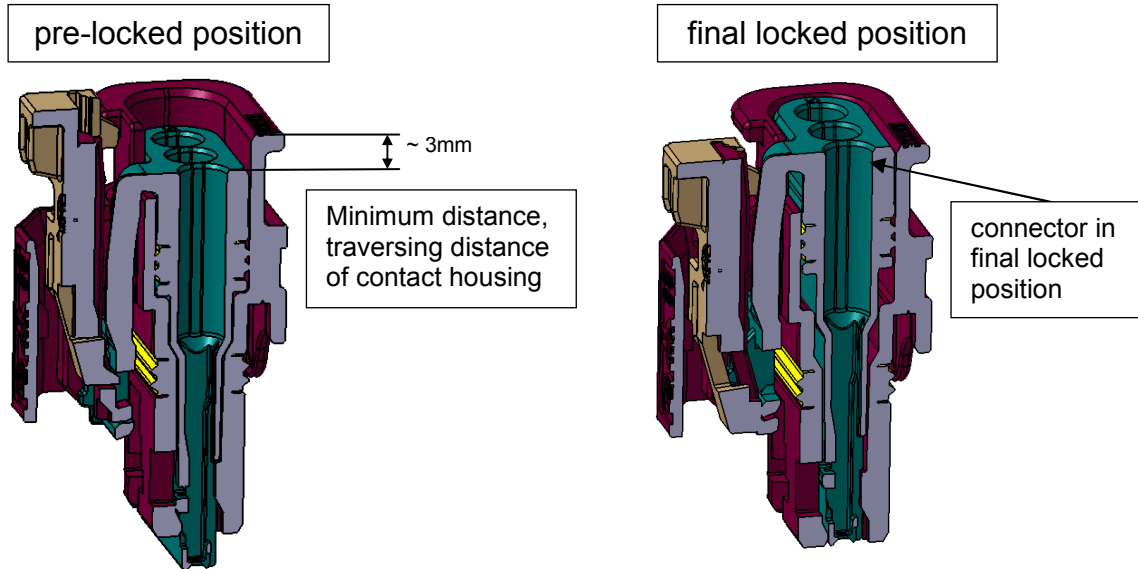

Between corrugated pipe and contact housing has to be a minimum distance of 3mm.



The corrugated pipe must not blocking the traversing distance of contact housing.



8. Index change table

Edition	Index	Editing
00	First edition	Klocker
01	6.1+6.2 Housing mounting and dismounting description updated	Kalb
02	Free space to shift the contact housing added (Point 7.)	Fetz