

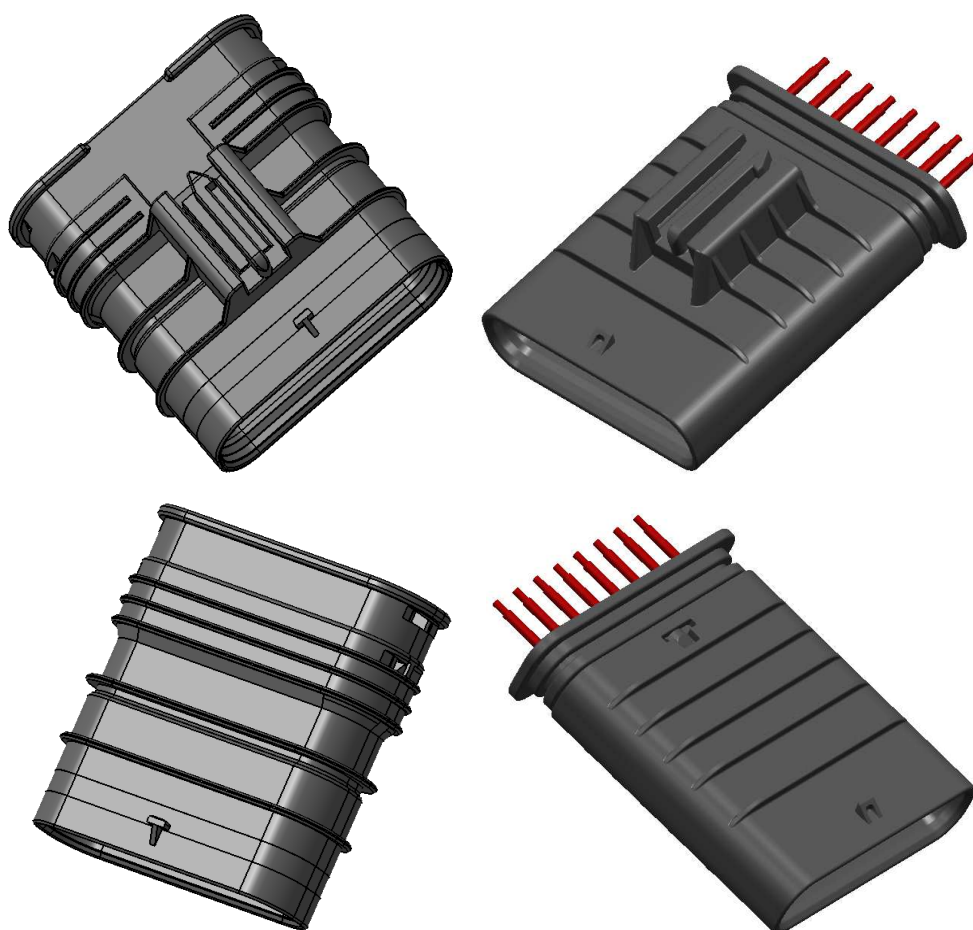

HIRSCHMANN
AUTOMOTIVE

Handling Manual

1.2 Seal Star M Connector single-row and double-row



EVS-100014-00
Version 02



1. Index

1. Index	2
2. General Information	3
2.1. Introduction	3
2.2. Applying relevant Information/Documentation	4
3. Delivery Condition / Product Components	5
3.1. Delivery Condition single-row	5
3.1.1. Option with slider	5
3.1.2. Option without slider	5
3.2. Delivery Condition double-row	6
4. Terminals	7
5. Matching protective caps, cover caps, end caps or transport caps	7
6. Insertion and Removal of 1.2 Terminals from the Connector	8
6.1. Assembling of 1.2 Contacts single row	8
6.1.1. Primary Lock	8
6.1.2. Secondary Lock with slider	9
6.1.3. Secondary Lock without slider	10
6.2. Assembling of 1.2 Contact double row	11
6.2.1. Primary Lock	11
6.2.2. Secondary Lock	12
6.3. Removing of the 1.2 Terminal	14
6.3.1. Removing of the 1.2 Terminals (single row connector with slider)	14
6.3.2. Removing of the 1.2 Terminals (single row connector without slider)	15
6.3.3. Removing of the 1.2 Terminal (double row connector)	16
7. Connect and disconnect of a Connector single row or double row	17
7.1. Connection the female housing without CPA	17
7.2. Disconnection the female housing without CPA	17
7.3. Connection the female housing with CPA	18
7.4. Disconnection the female housing with CPA	18
7.5. Housing without protective shroud (inertia connection)	19
7.6. Disconnection Housing without protective shroud	19
8. Index change table	20



2. General Information

2.1. Introduction

This handling manual is valid for all variants, keys and options of the 1.2 SealStar male connectors and describes the delivery conditions, the individual components as well as the assembly and disassembly of the connector and terminals.

Based on the processing specification of contact suppliers the contact assembling and disassembling is described.

The harness maker is responsible to follow all processing specification and other relevant rules and regulations.

In case of inappropriate/incorrect assembly a damage claim will be rejected.



2.2. Applying relevant Information/Documentation

Customer drawings Hirschmann Automotive:

2-way 1.2 SealStar Male housing	872-863-...00
3-way 1.2 SealStar Male housing	872-658-...00
3-way 1.2 SealStar Male housing	872-837-...00
4-way 1.2 SealStar Male housing	872-617-...00
5-way 1.2 SealStar Male housing	806-974-...00
8-way 1.2 SealStar Male housing	872-555-...00
16-way 1.2 SealStar Male housing	805-588-...00
„Deutsche Norm“ DIN EN 60352-2	solderfree electrical connection part 2: crimp connection
MLK 1.2 contact pin (Kostal)	10322345-1
Processing Specification (Kostal) DOC00061540	Mini lamina contacts MLK 1.2
TAB contact 1.2mm (TE)	C-1418754
Application Specification (TE) 114-18464	MCON 1.2mm Contact System

3. Delivery Condition / Product Components

3.1. Delivery Condition single-row

The connector, consisting of a shroud, a seal, a contact carrier and optionally a slider. The contact carrier is pre-assembled in the shroud and the optionally slider is in pre-position. The secondary lock is open.

These connectors are available in inertia and snap locking versions.

In this specification the illustrations are limited to the snap locking version. The processing of the inertia locking version applies analogously.

3.1.1. Option with slider

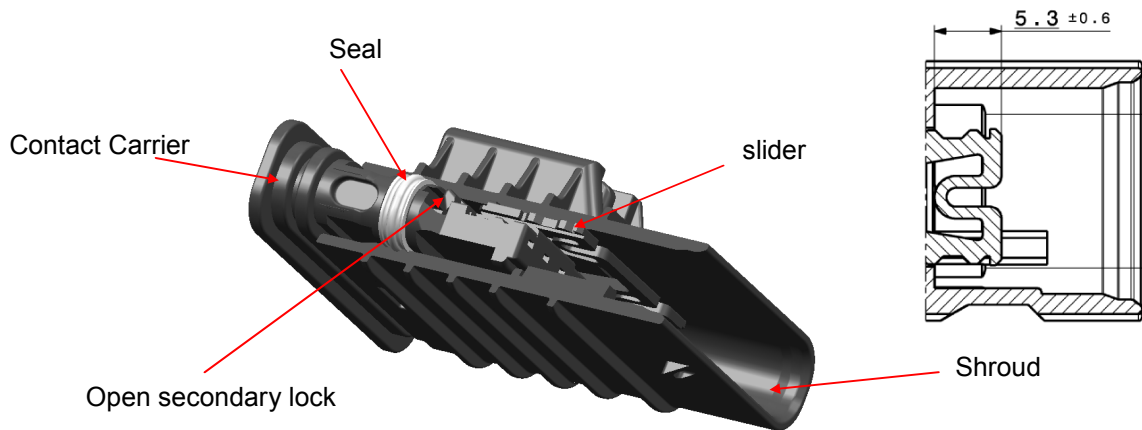

3.1.2. Option without slider

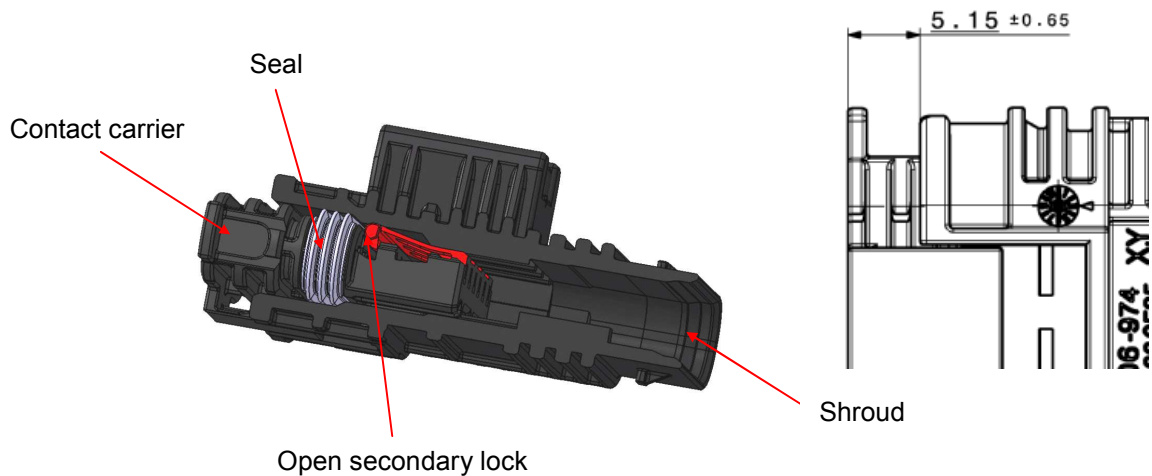

3.2. Delivery Condition double-row

The connector, consisting of a shroud, a seal and a contact carrier. The contact carrier is pre-assembled in the shroud and the secondary lock is open.

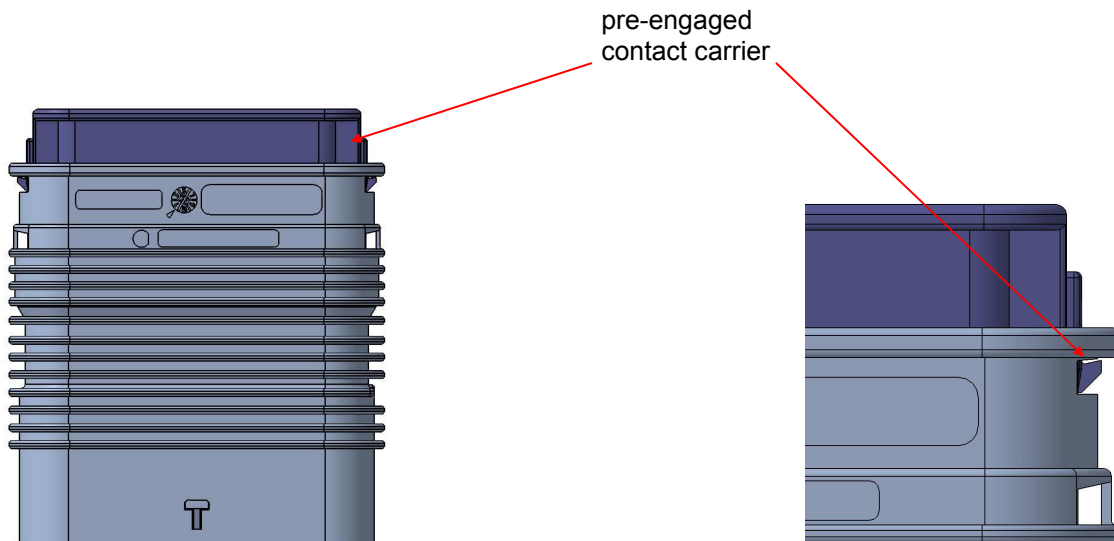
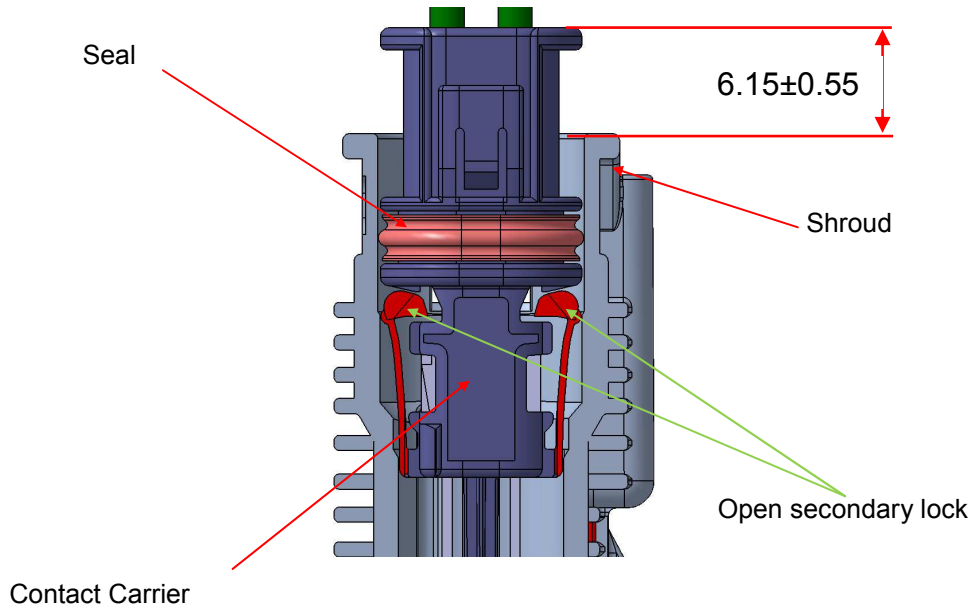



4. Terminals

Please see terminal manufacturer drawing for processing requirements

To guarantee the required sealing performance the terminals and seals must fit the wire and all open cavities must be plugged with cavity plugs (except if the cavity is pre-flashed).

Crimp tools, e.g. applicators, hand crimp tools and removal tools - please see process specification of the terminal manufacturer.

Only contacts for which a release of the OEM is available may be used. This has to be clarified by the harness maker.

5. Matching protective caps, cover caps, end caps or transport caps

The connectors are available from various manufacturers with the appropriate attachment parts. Details on availability can be found in the customer drawing or clarified with the respective manufacturers.

f.ex. Pöppelmann, Schlemmer, ...

6. Insertion and Removal of 1.2 Terminals from the Connector

6.1. Assembling of 1.2 Contacts single row

6.1.1. Primary Lock

The connector is delivered ready for assembly.
The contacts will be inserted in the connector until a click is audible.

Attention: For connectors with slider, it must be ensured before assembly that the slider is not pushed out of the assembly position by previous process steps !

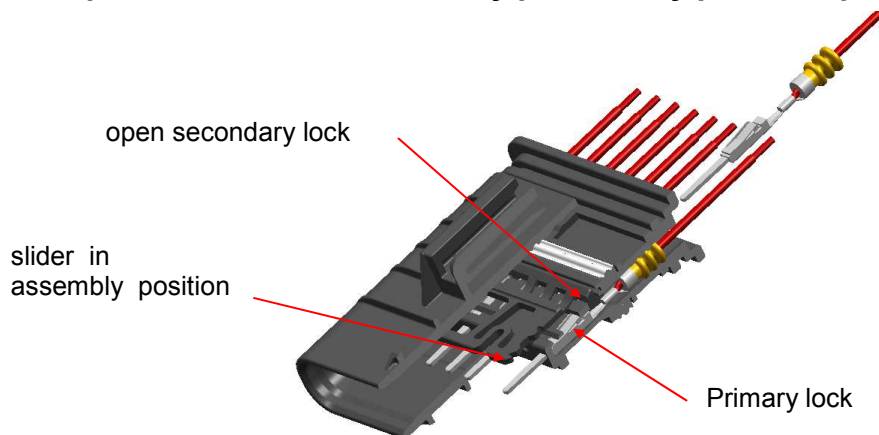

Attention: For connectors without slider, it must be ensured before assembly that the contact carrier is not pushed out of the assembly position by previous process steps !

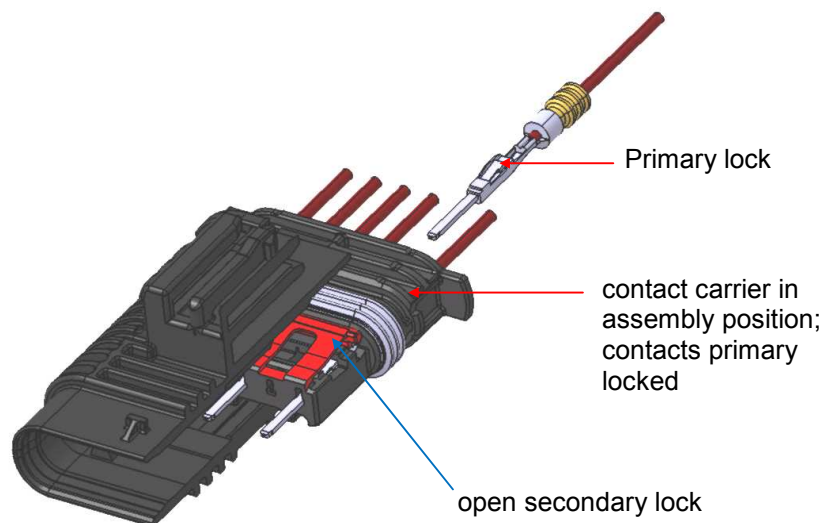

6.1.2. Secondary Lock with slider

After the terminals are inserted into the contact carrier (primary lock active), the secondary lock must be activated by pressing the slider into end position. To move the slider, only the **red** marked areas may be used. A uniform force distribution on the **red** marked areas parallel to the direction of displacement is to be ensured.

The slider should be moved to the height of the contact carrier.

The maximum operating force of the slider is 80N.

Please mind that the contacts or seal area must **not be touched by any used tool!**

This displacement of the slider into the final locking position may be performed at a speed of max. 300mm/s !

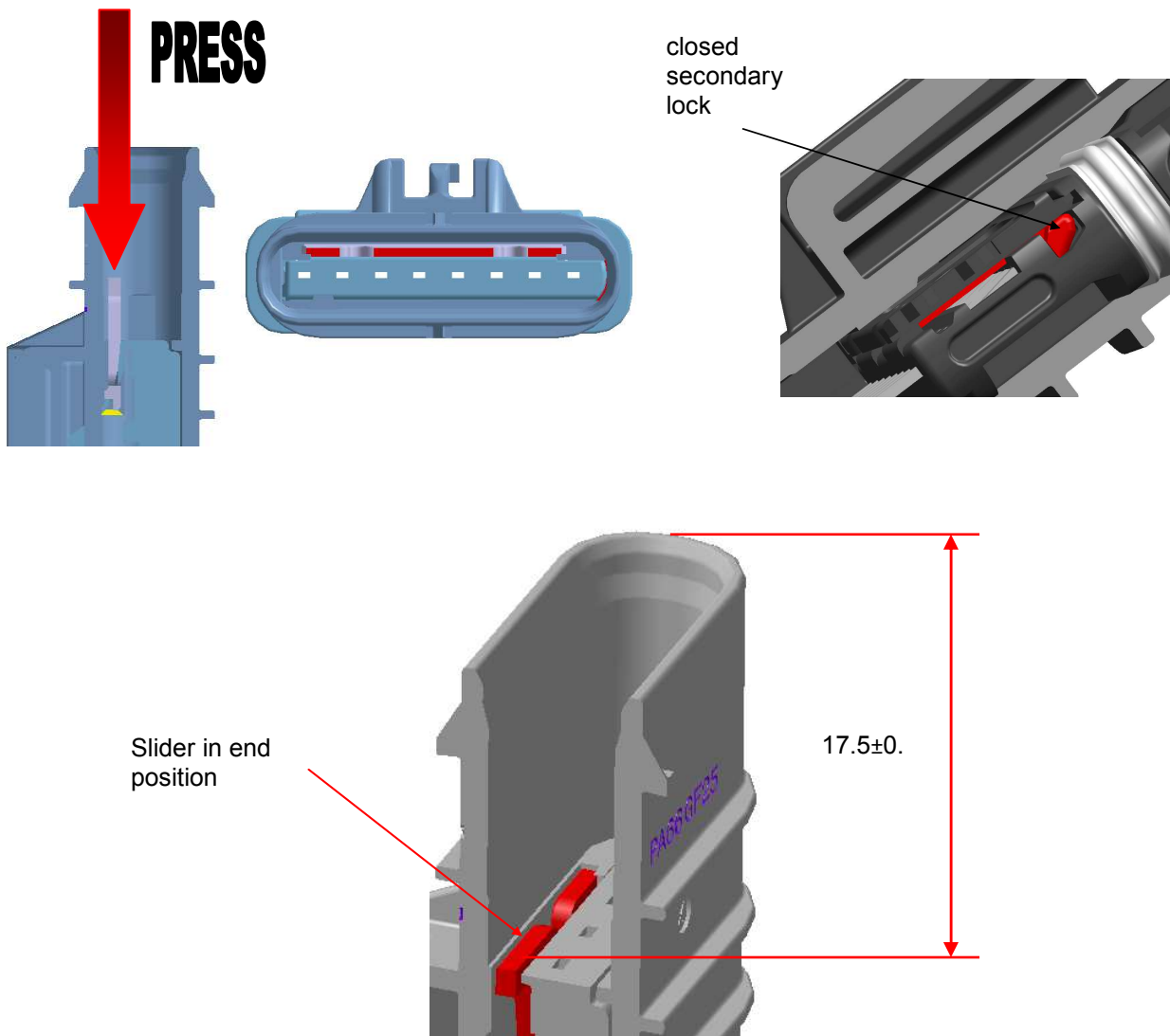

6.1.3. Secondary Lock without slider

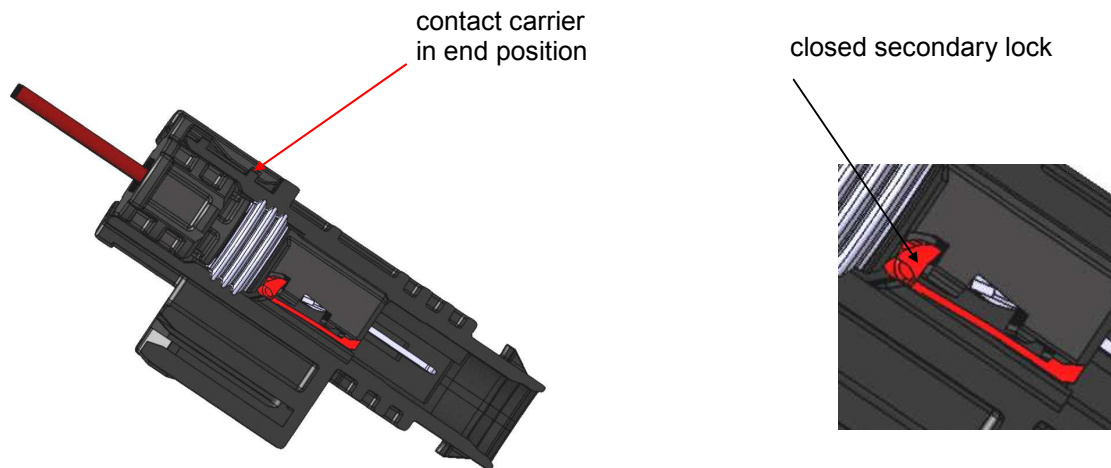

After the terminals are inserted into the contact carrier (primary lock active), the secondary lock must be activated by pressing the contact carrier into the shroud. The maximum displacement force of the contact carrier is 80N.

This displacement of the contact carrier into the final locking position may be performed at a speed of max. 500mm/min.

6.2. Assembling of 1.2 Contact double row

6.2.1. Primary Lock

The connector is delivered ready for assembly.

The contacts will be inserted in the connector until a click is audible.

Attention: Check that the contact carrier is in the assembly position prior inserting the terminals!

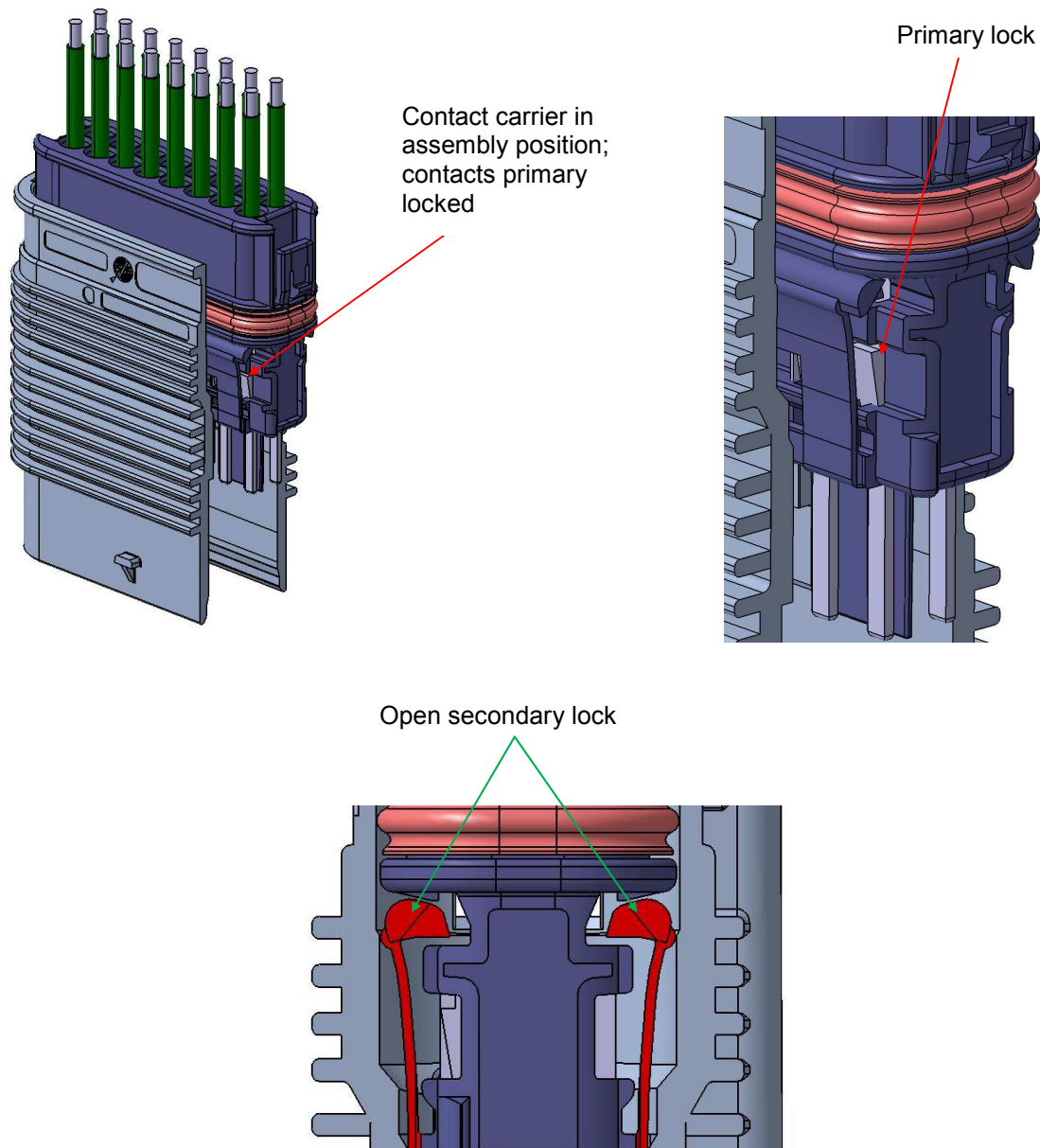

6.2.2. Secondary Lock

After the terminals are inserted into the contact carrier (primary lock active), the secondary lock must be activated by pressing the contact carrier into the shroud.

To press the contact carrier into the shroud to its final position, press only on **red** marked areas (1). Ensure that the surfaces (1) are pressed down evenly in one continuous motion. There is a maximum mounting speed of **500mm/min** permitted!

The contact carrier is locked when the locking latch hooks were engaged as shown below. When using assembly equipment, the maximum power is limited to **120N**. A higher force is an indication of not properly seated contacts.

12-way

Pre-engaged position 1

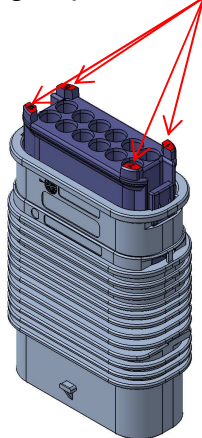

Final position

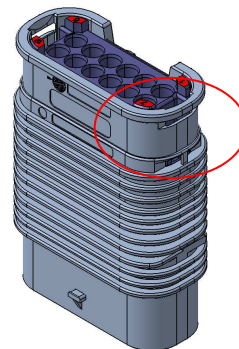

16-way

Pre-engaged position 1

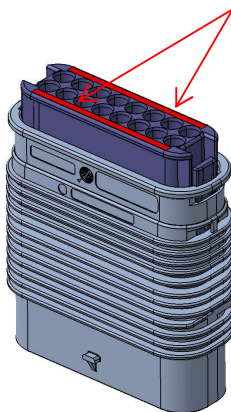

Final position

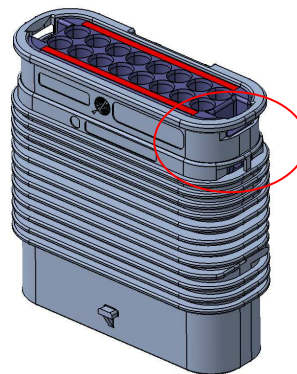

Check that the locking latch hook is in locking position

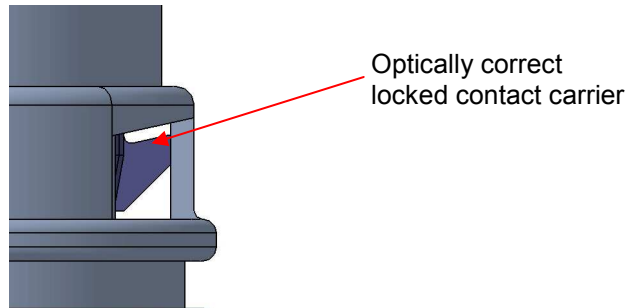

Note: It is not an indication of a closed lock if the contact carrier top sits flush in the shroud!

Only when the latch hook is in the locked position is the contact carrier properly locked in the shroud!

12-way

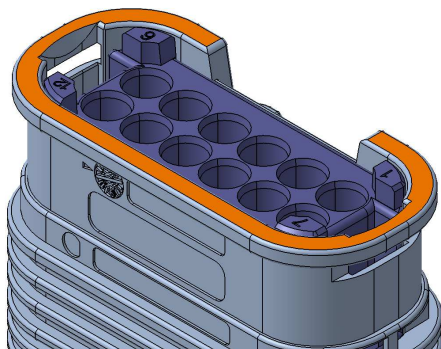

16-way

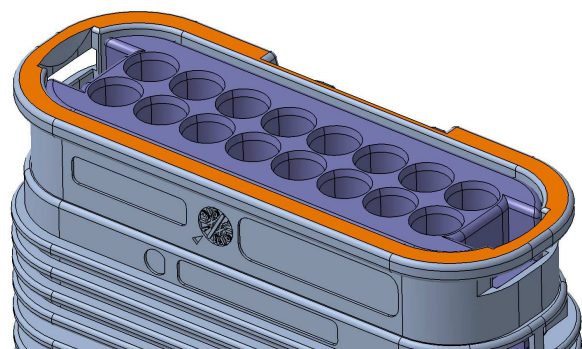

Contact Carrier fully seated

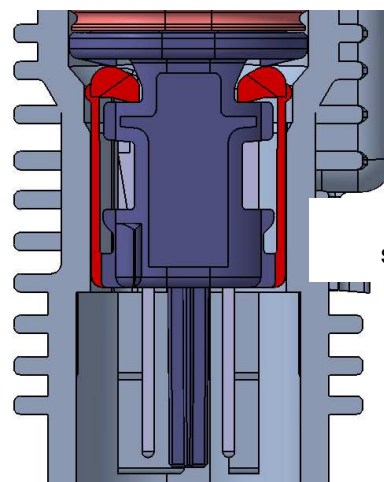
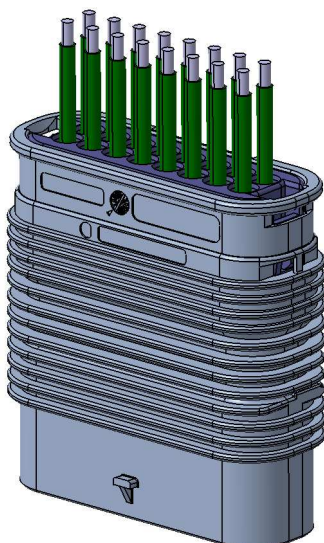

Closed
secondary lock

6.3. Removing of the 1.2 Terminal

The contacts can be removed for repair. Therefore the contact carrier has to be separated from the shroud.

6.3.1. Removing of the 1.2 Terminals (single row connector with slider)

By lifting or removing the locking window with a suitable tool (screwdriver 2.5x75), the contact carrier can be released in the direction shown from the shroud. This will damage or destroy the locking window, so reuse is **not** allowed.

After the contact carrier is removed from the shroud, the secondary lock can be bent or broken off. After deactivating the secondary lock, the primary lock of the contact can be carefully actuated. Subsequently, the contact can be pulled or pushed out of the chamber.

Attention: Do not pull on wires!

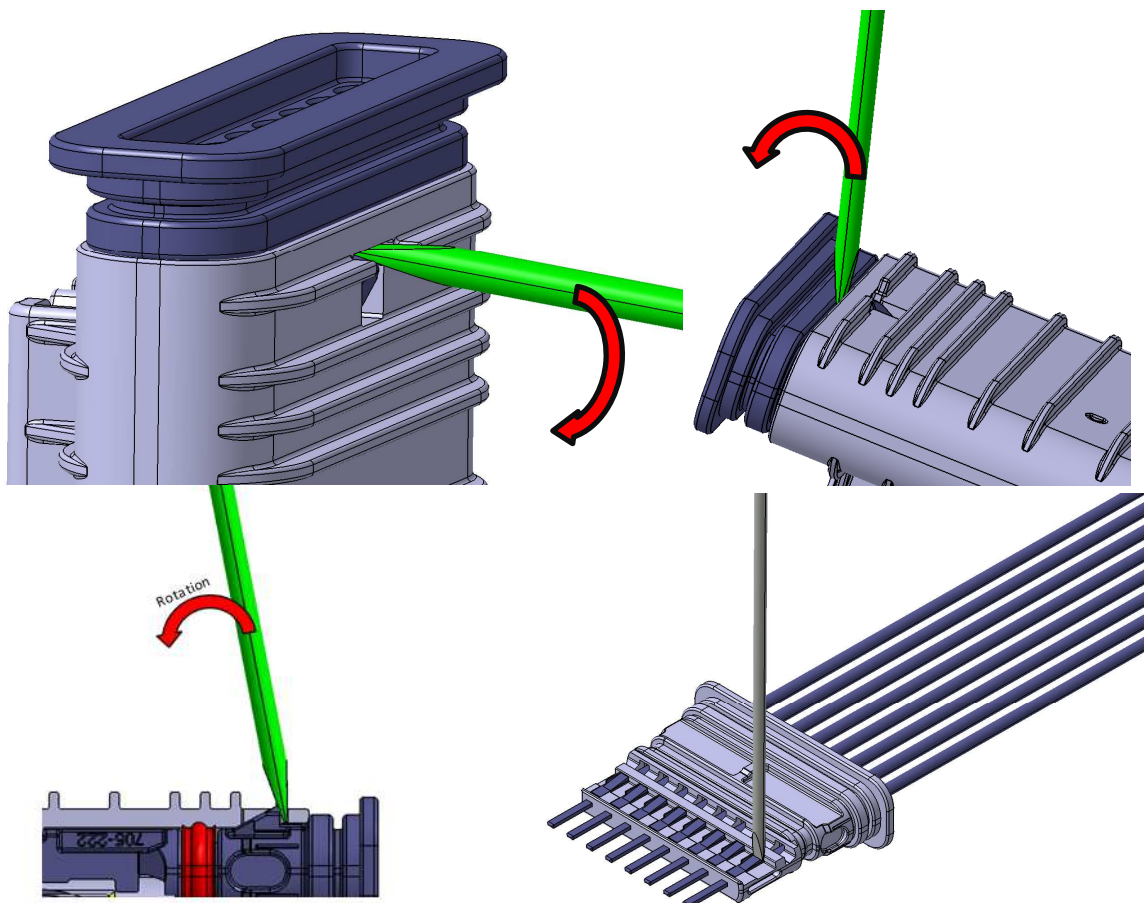

Attention: After removing the contacts out of the connector you have to use a new one.

6.3.2. Removing of the 1.2 Terminals (single row connector without slider)

By lifting the hook with a suitable tool, the contact carrier can be brought from end to pre-position.

For this purpose, the tool must be attached to the gap between the hook and the shroud and then the hook can only be lifted so far until the contact carrier can be pulled into the pre-position.

If the latching hook is raised too much, its functionality may be limited.

After deactivating the secondary lock, the primary lock can be deactivated according to the processing specification of the contact manufacturer.

Attention: Do not pull on wires!

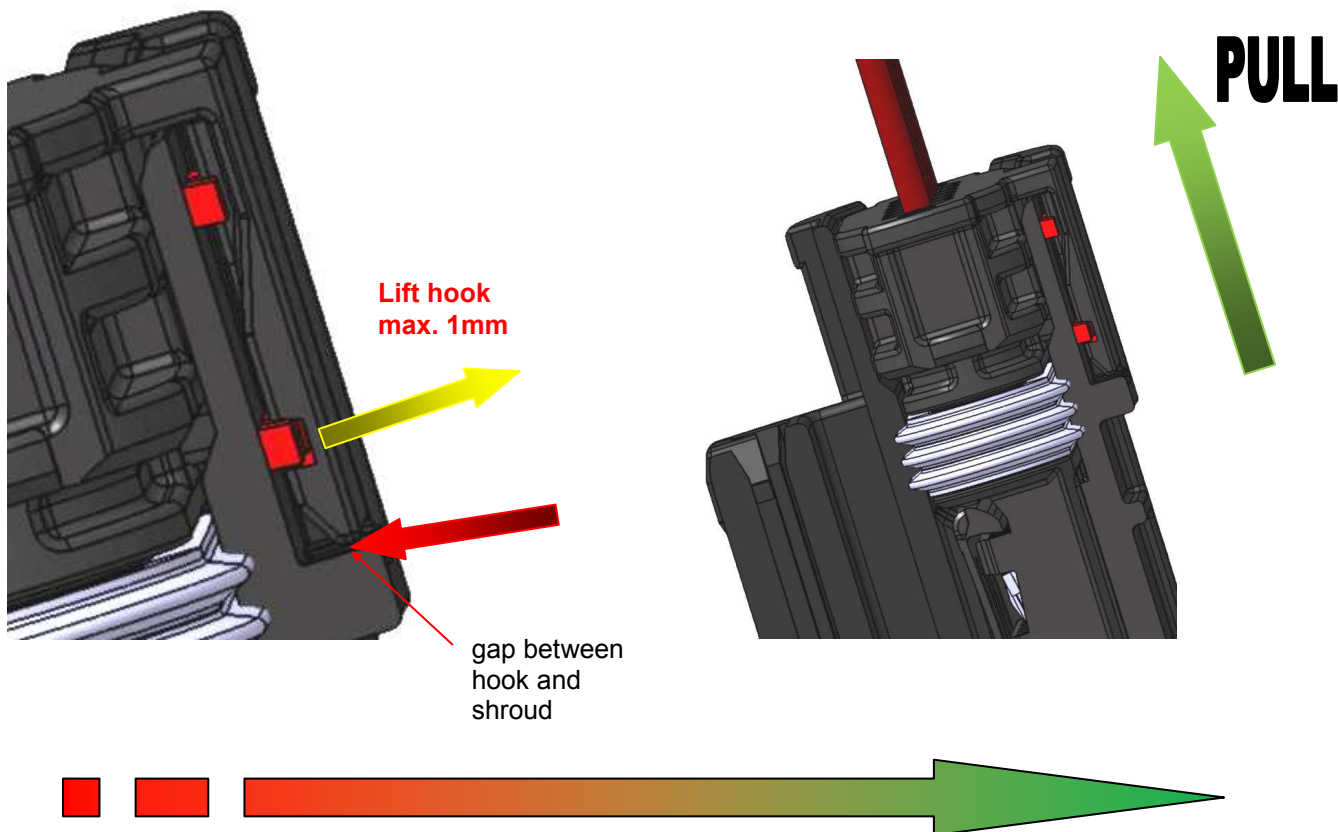

Before reassembling the connector, it must be ensured that the hook is undamaged and the contact carrier is in the pre-locked position !

6.3.3. Removing of the 1.2 Terminal (double row connector)

Open the latches with a screw driver (F1). Move the contact carrier into delivery position (pre-engaged) by pulling on the contact carrier (F2). The secondary locking mechanism is now open.

If the latch is lifted – the connector will be damaged and should not be used anymore.

The primary lock of the terminal can be opened and the terminal can be removed (following the processing specification of the terminal manufacturer).

Attention: Do not pull on wires!

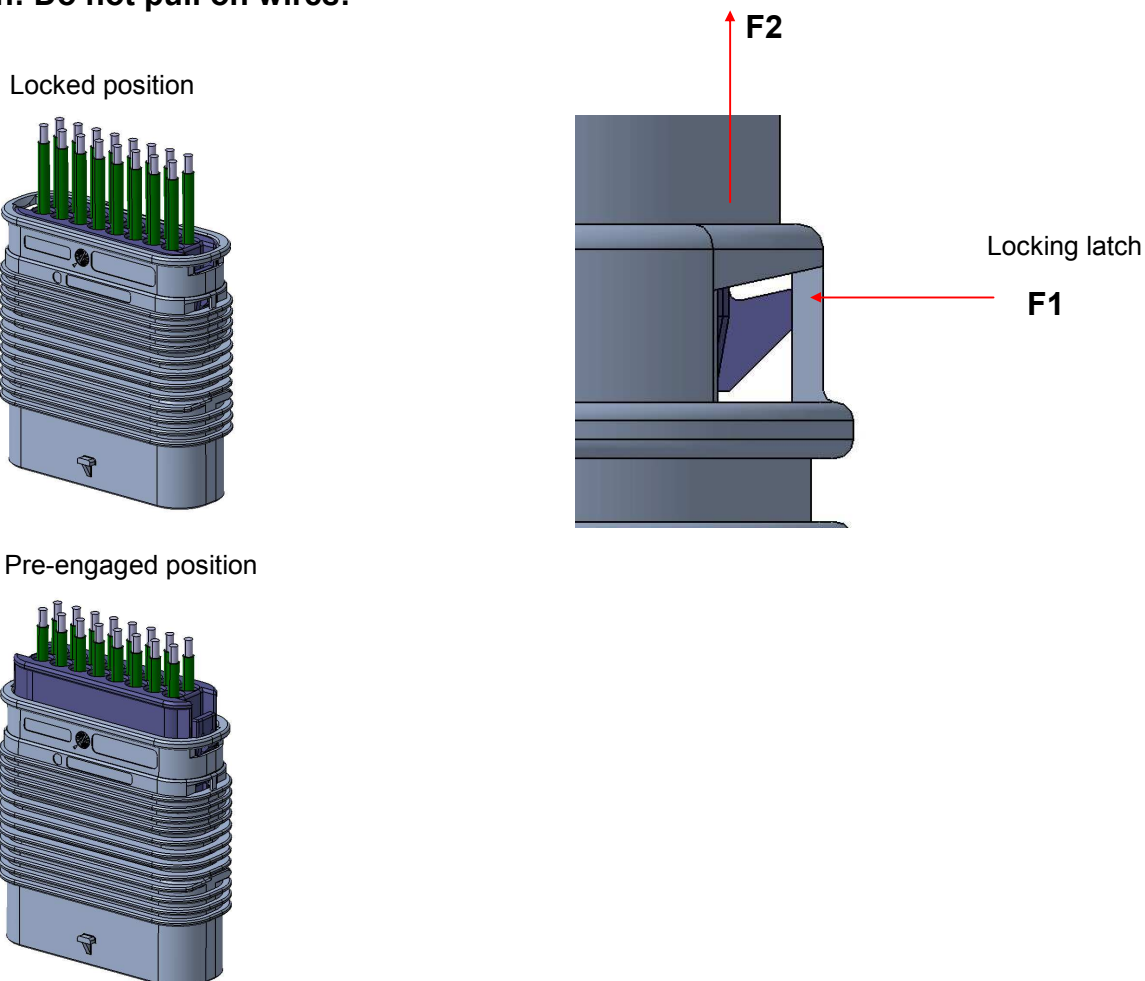

Attention: After removing contacts from the contact carrier, a new connector must be used!

7. Connect and disconnect of a Connector single row or double row

7.1. Connection the female housing without CPA

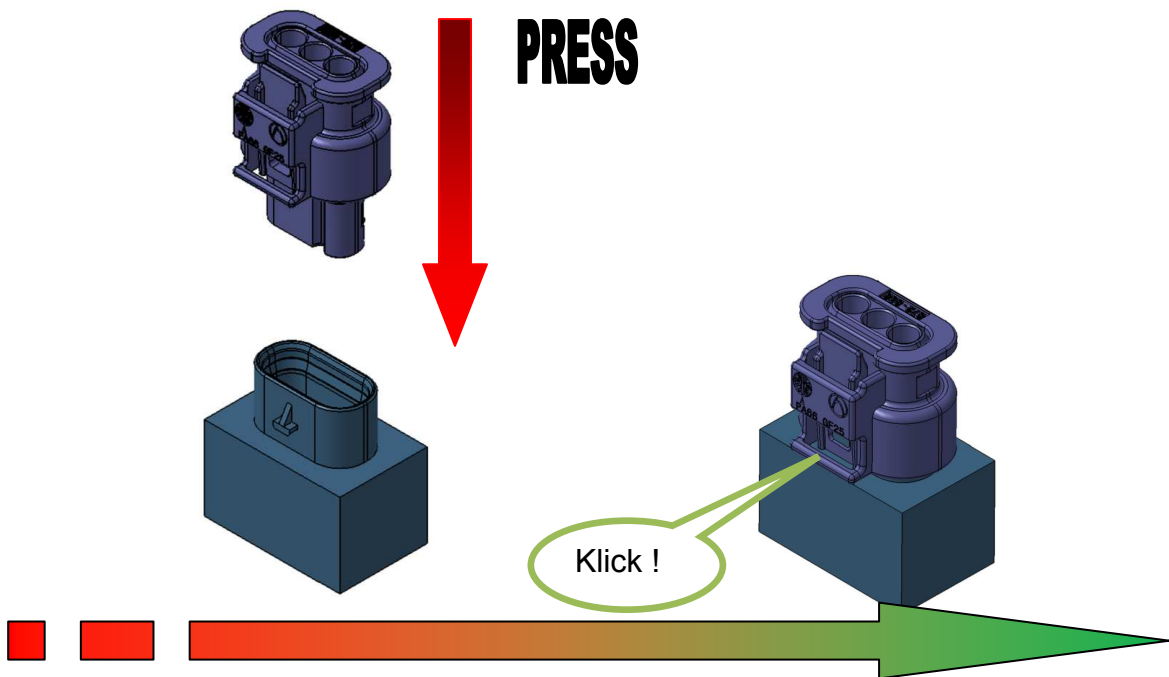

7.2. Disconnection the female housing without CPA

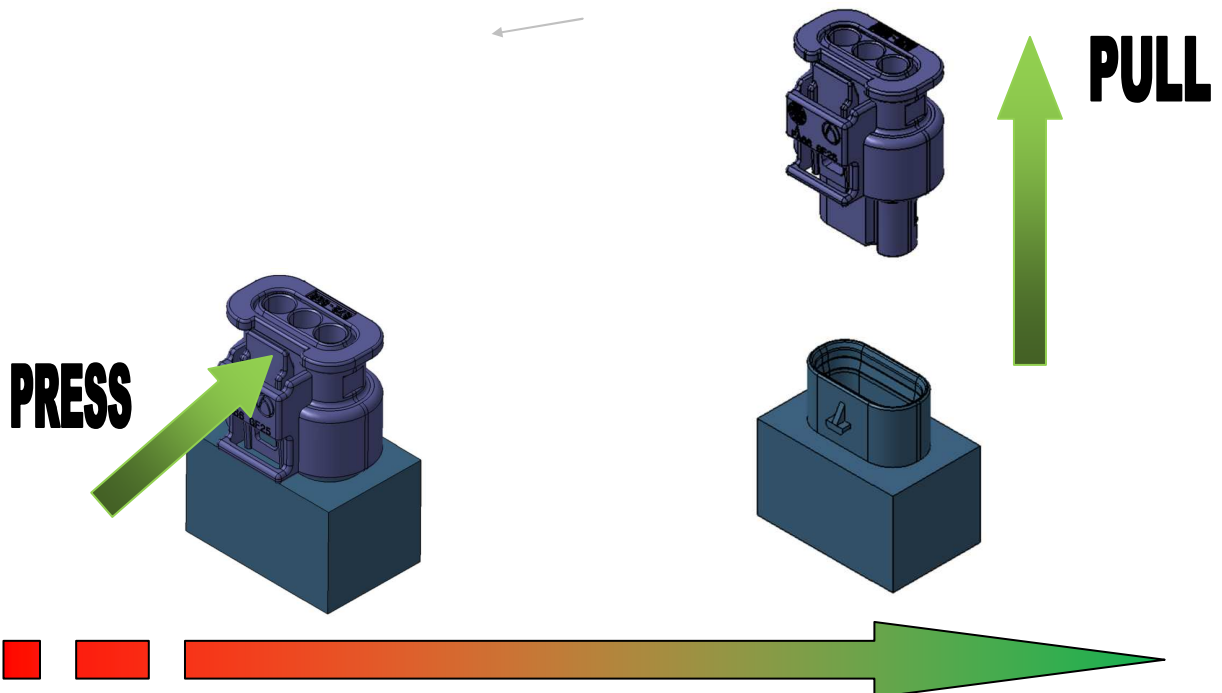

7.3. Connection the female housing with CPA

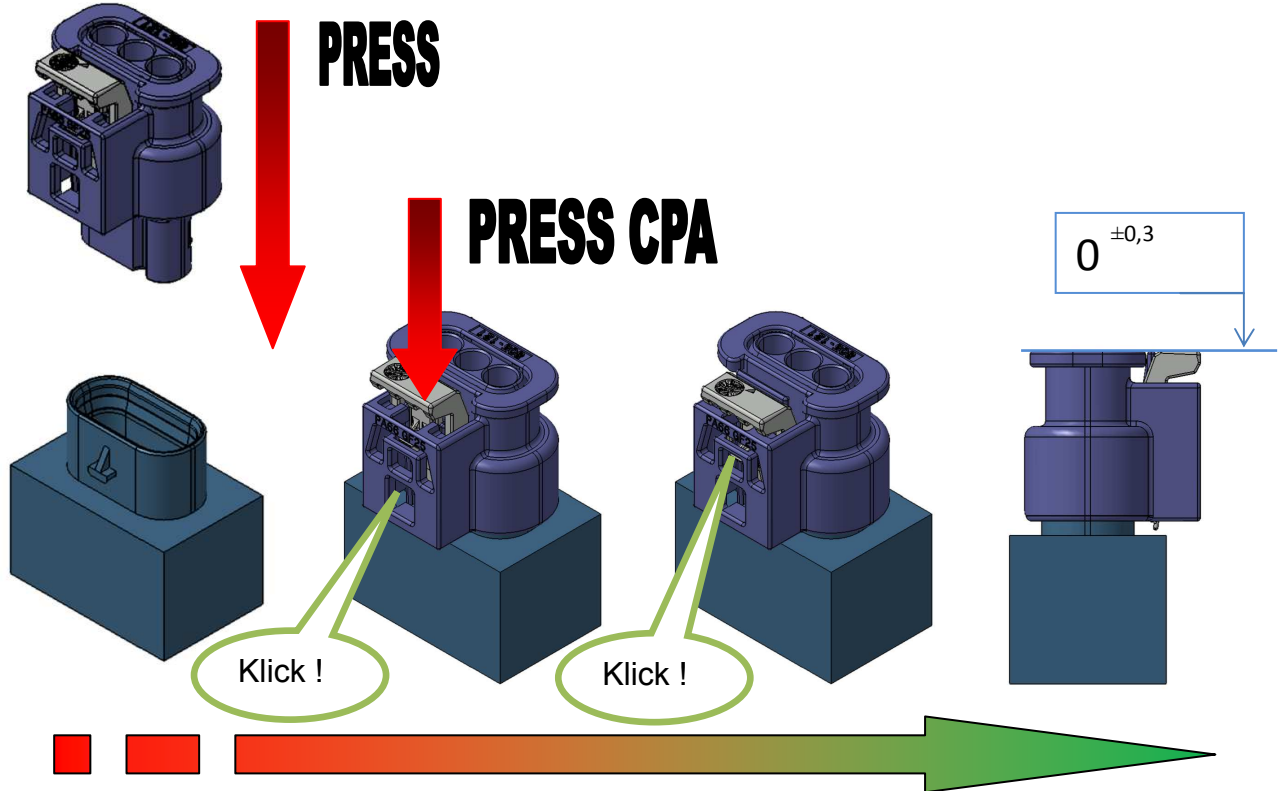

7.4. Disconnection the female housing with CPA

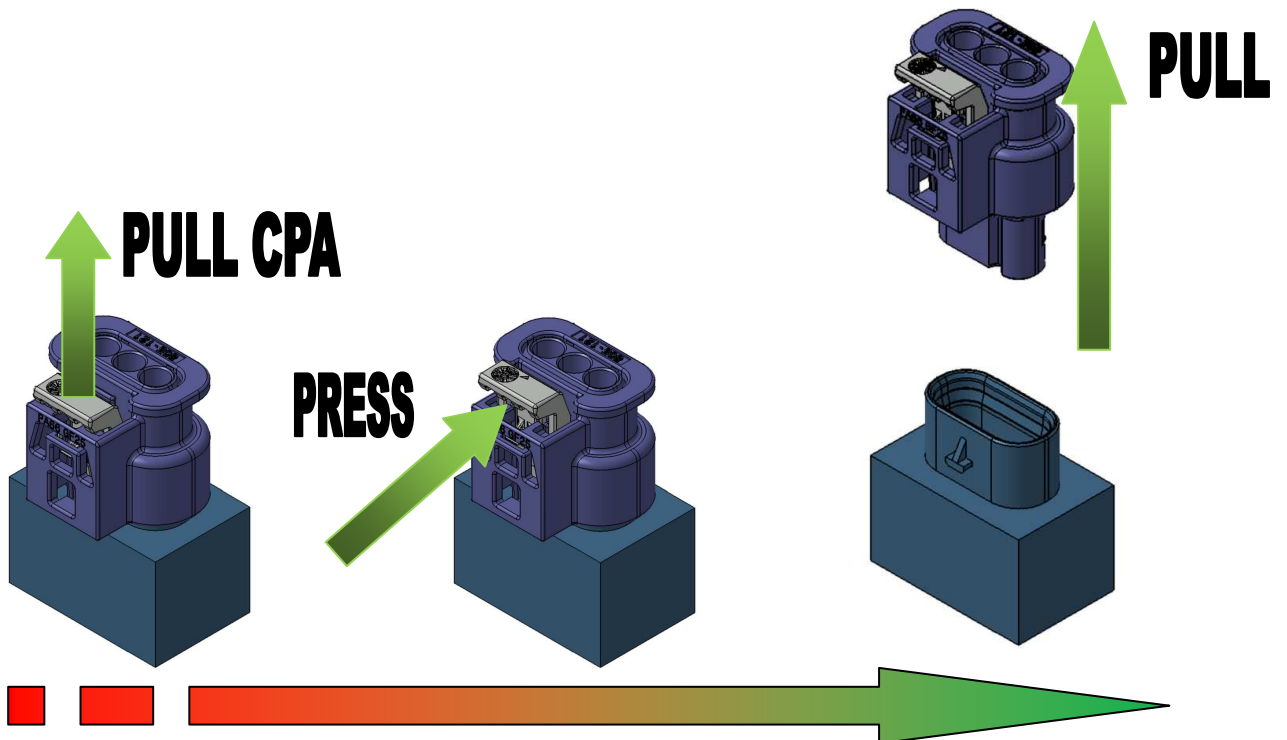

7.5. Housing without protective shroud (inertia connection)

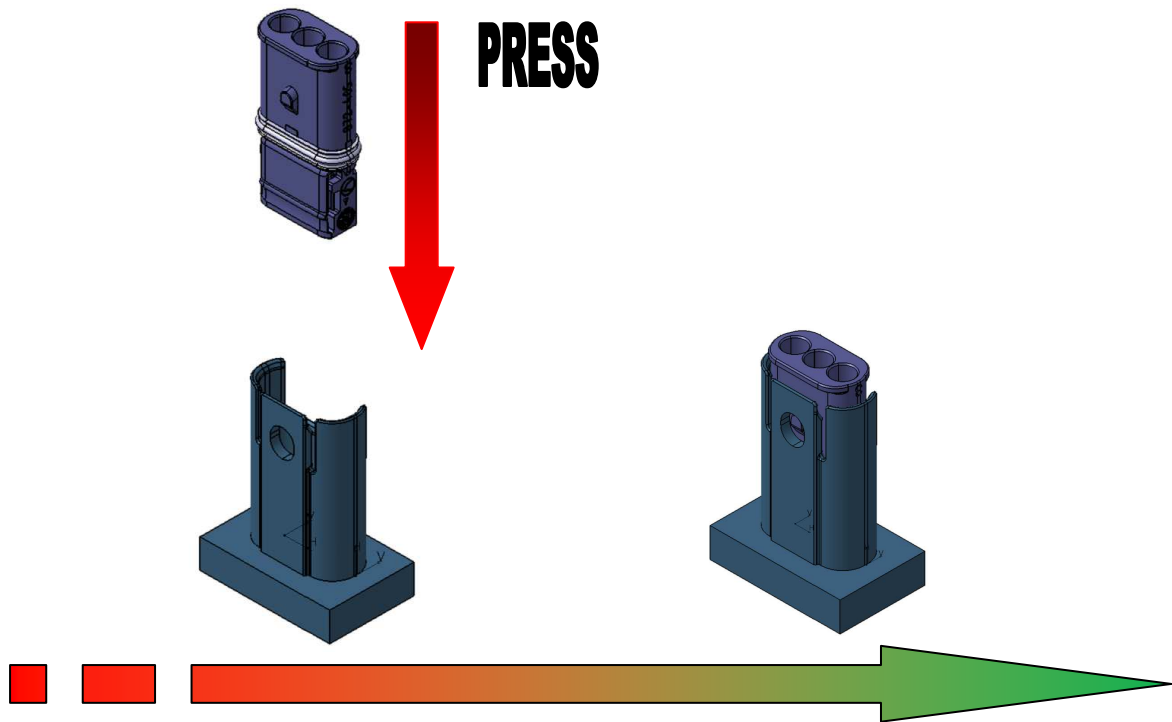

7.6. Disconnection Housing without protective shroud

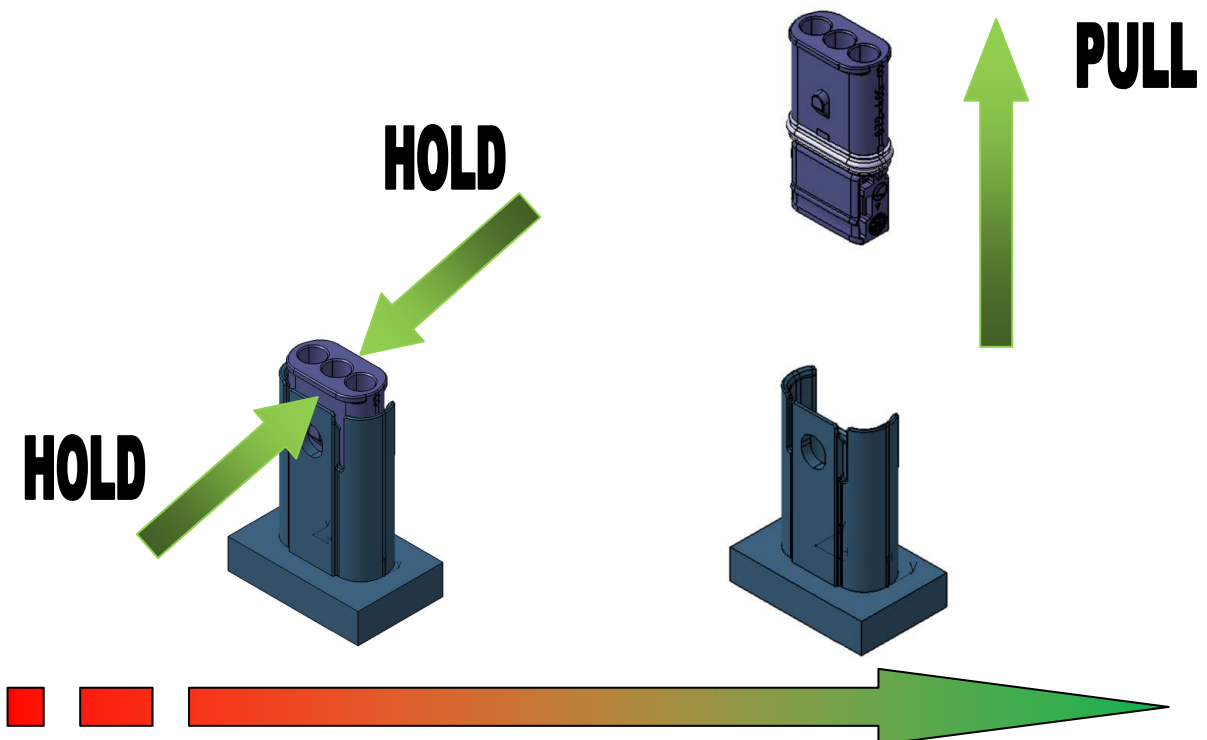



8. Index change table

Version	Index	Editing
00	first edition	Kiechle
01	Addition of the one row pin housing, revision of whole document.	Denz
02	Complete reworked	Bürk